



VOLUME 32 EU



pure LIGHTING
EXCITEMENT

AMERICAN AUDIO®

reliable lighting products for clubs,
Restaurants, schools, bands and theatres.

www.adj.eu



Starting in 1985, as a supplier of lighting products to mobile entertainers, the Los Angeles-based ADJ Group has grown into a diversified global enterprise which collectively provide lighting and audio products for home, architectural, stage, touring and mobile entertainment applications, as well as trussing for displays, events and stage productions.

With offices on five continents, the company has earned an international reputation for quality, reliability and unwavering loyalty to its retail partners. ADJ is still operated by its founders. With more than 250 employees the ADJ Group belongs to the world's largest entertainment electronics companies and continues to grow.

The company has also followed a philosophy of innovation, and has been responsible for many breakthroughs in the professional lighting industry. Designed with the end-user in mind, its products have been profitable sellers at a wide variety of retail outlets from independent specialty stores through the qualified ADJ partner network to major retailers like CPC, Conrad, Best Buy and Amazon.

Its products have also been specified for many major concert tours, including John Mayer, Bon Jovi and Brad Paisley as well as at high profile architectural application, such as the Luxor and Venetian hotels in Las Vegas, Royal Caribbean International's Oasis of the Sea (the world's largest cruise ship) and at major attractions like Disneyland and Universal Studios theme park.

With a proven track record of filling orders on time and standing behind everything it sells, the ADJ Group can help put any venue in lights!

„Lighting the future!“





CONTENTS

AV Products.....	6 - 8
Moving Heads.....	9 - 25
Scanners & Rollers.....	26 - 27
Visual Effects.....	28 - 29
KlingNet Pixel Product.....	30 - 32
Wifly & Battery Powered Fixtures.....	33 - 40
Wash Lighting.....	41 - 56
Linear Fixtures.....	57 - 59
LED Effects.....	60 - 67
Laser Effects.....	68 - 69
Blacklight UV Effects.....	70 - 72
Gobo Projectors / Followspots.....	73 - 81
Atmospheric Effects.....	82 - 88
Bubble Effects.....	89
Atmospheric Effect Controllers.....	90
Atmospheric Fluids.....	91
Mirror Ball Motors.....	93
Stands.....	94 - 96
Clamps.....	97 - 98
Accu Case™.....	99 - 113
Cable™.....	114 - 122
Lighting Controllers/Software.....	123 - 132
American Audio.....	133 - 145

ADJ PRODUCTS

3D Vision.....	28
5P Hex.....	47
5P Hex Pearl.....	47
7PZ IP.....	34
12P HEX.....	47
12P HEX Pearl.....	47
18 P Hex.....	46
Airstream DMX.....	124
Ani-motion.....	69
Asteroid 1200.....	21
AV3.....	6
AV6X.....	7
BL40.....	141
BL60.....	141
Boom Box FX1.....	62
Boom Box FX2.....	62
Bubbletron.....	89
Bubbletron XL.....	89
Bubbletron GO.....	89
Chameleon Qbar.....	42
COB Cannon DW.....	44
COB Cannon Wash.....	44
COB Cannon Wash Pearl.....	44
Color Strand Led.....	61
CPX Series.....	133
Crazy 8.....	23
Crazy Pocket 8.....	23

D6 Branch.....	125
DB Display.....	138
DJ MTS 4.....	93
DMX Operator 1.....	129
DMX Operator 384.....	126
Dotz Matrix.....	43
Dotz Par.....	45
Dotz Par 100.....	45
Dotz TPar System.....	55

Eco UV Bar DMX.....	72
Eco UV Bar IR.....	72
Eco UV Bar Plus IR.....	72
ELS Go Series.....	134
Encore Profile 1000 WW.....	74
Encore Profile 1000 Color.....	74
Entourage.....	83
Entour Venue.....	83
Event Facades.....	144
EZ Kling.....	31

Flash Kling Batten.....	30
Flash Kling Panel 64.....	29
Flash Kling Strip.....	30
Flash Rope.....	71
Flat Par QA5XS.....	51
Flat Par QA12XS.....	50
Flat Par QWH5XS.....	51
Flat Par QWH12XS.....	50
Flat Par Tri7XS.....	52
Flat Par Tri18XS.....	52
Flat Par TW5.....	54
Flat Par TW12.....	54
Focus Spot One.....	19
Focus Spot Two.....	18
Focus Spot Three Z.....	17
Focus Spot Three Z Pearl.....	17
Fog Fury 1000 II.....	84
Fog Fury 2000.....	84
Fog Fury 3000.....	84
Fog Fury Jett Pro.....	86
Fog Fury Jett.....	87
FS600LED.....	76

H20 DMX IR.....	81
H20 IR.....	81
HEXCON.....	48

Ikon IR.....	76
Ikon Profile.....	75
Ikon Profile Pearl.....	75
Ikon Profile WW.....	75
Ikon Profile WW Pearl.....	75
Illusion Dotz 3.3.....	16
Illusion Dotz 4.4.....	16
Inno Color Beam Z7.....	14
Inno Color Beam Z19.....	14
Inno Pocket Roll.....	27
Inno Pocket Scan.....	27
Inno Pocket Spot Pearl.....	20
Inno Pocket Spot.....	20
Inno Pocket Spot LZR.....	20
Inno Pocket Z4.....	15
Inno Roll HP.....	26
Inno Scan HP.....	26

KAOS.....	22
-----------	----

LED Color Tube II.....	56
LED Master.....	31/130
LED Pixel 4C.....	32
LED Pixel Tube 360.....	32
LLS Stands.....	94
LTS 6.....	93

Magna Tube.....	56
MCTRL300.....	8
Media Operator BT.....	138
Mega 64 Profile Plus.....	63
Mega Tripar Profile Plus.....	63
Mega QA Go.....	49
Mega Q Plus Go.....	49
Micro 3D II.....	68
Micro Galaxian II.....	68
Micro Royal Galaxian II.....	69
Micro Gobo II.....	68
Mini Dekker.....	66
Mini Dekker LZR.....	66
Mini Tri Ball II.....	67
Mirrorballs.....	92
Mister Kool II.....	88
MyDMX 3.0.....	123
MyDMX Buddy.....	125

Ninja 5RX.....	21
Novastar VX4S.....	8

Par Z4.....	46
Penta Pix.....	61
Pinpoint GO Color.....	80
Pinpoint GOBO Color.....	77
Pinpoint GOBO.....	77
Pinpoint LED II.....	80
Pinpoint LED Quad DMX.....	80
Pixel Kling 10C.....	31
PXW 18P.....	134

Quad Phase HP.....	67
--------------------	----

Revo 4 IR.....	65
RGB3C IR.....	128
RGBW4 IR.....	128

Saber Spot WW.....	79
Saber Spot RGBW.....	79
Scene Setter.....	129
SDC6 V2.....	126
Sense Series.....	135-136
Starburst.....	65
Stinger.....	64
Stinger II.....	64
Stinger Gobo.....	63
Stinger Star.....	63
Sweeper Beam Quad LED.....	24

UC3.....	130
UCD Mixers.....	139
Ultra Bar 6.....	59
Ultra Bar 9.....	59
Ultra Bar 12.....	58
Ultra Hex Bar 6.....	57
Ultra Hex Bar 12.....	57
Ultra Hex Par3.....	48
Ultra Kling Bar 18.....	29
UV COB Cannon.....	71
UV Flood 36.....	71

VBar Pak.....	58	XEQ152B Equalizer.....	138
Vertigo Hex LED.....	67	XS200.....	25
VF400.....	85	XS400.....	25
VF1100.....	85	XS600.....	24
VF1300.....	85		
VF1600.....	85		
VF Flurry.....	88		
VF Snow Flurry HO.....	88		
VF Volcano.....	87		
Vizi Beam 5RX.....	12		
Vizi Beam Hybrid RXOne.....	12		
Vizi BSW 300.....	11		
Vizi Hex Wash7.....	13		
Vizi Hybrid 16RX.....	10		
Vizi Q Wash 7.....	13		
VLP Amplifiers.....	137		
VMS 5.....	141		
VPS Microphones.....	142		
WARLOCK.....	22		
WiFLY Bar QA5.....	37		
WiFLY Chameleon.....	42		
WiFLY D6 Branch.....	39		
WiFLY EXR Battery.....	39		
WiFLY EXR DOTZ PAR.....	38		
WiFLY EXR HEX PAR.....	36		
WiFLY EXR Hex5 IP.....	35		
WiFLY EXR QA5 IP.....	35		
WiFLY EXR QA12Bar IP.....	36		
WiFLY Par QA5 IP.....	38		
WiFLY Par QA5 WH.....	37		
WiFLY Par QA5.....	37		
WiFLY NE1.....	40/124		
WiFLY RGBW8C.....	40/127		
WiFLY WLC16.....	44		



www.adj.eu

Log onto to American DJ and American Audio's official web site for up-to-the-moment new product information, press releases, user manuals, and product videos. You can also register your product online, join take part in the DJ and lighting Forums and look for a local American DJ/American Audio Authorized Dealer in your area. Don't forget to join our e-mail list to get the ADJ News Wave each month!



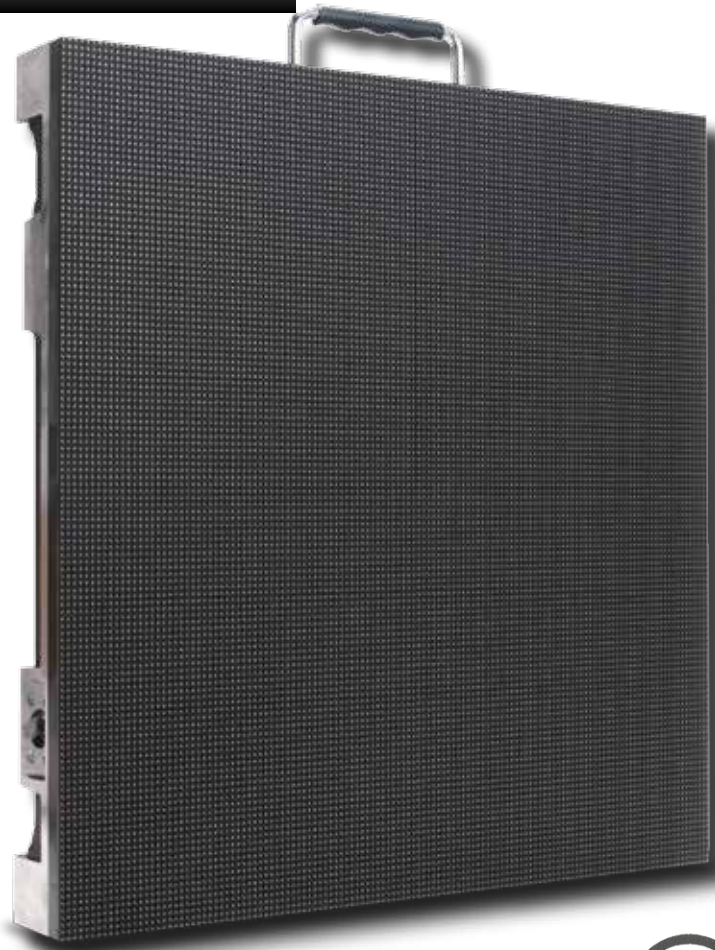

AV3

NEW!

1226300055

SPECIFICATIONS:

- Pixel Pitch: 3.91mm (0.25")
- LED Configuration: 3-in-1 SMD2121 LED
- Pixel Density: 128x128; 65536 per square meter
- Size :19.75" x 19.75" x 4" / 500 x 500 x 100mm
- Module Quantity: 2
- Weight: 20 lbs. / 9kg.

MECHANICAL RATINGS:

- Surface Flatness: Gaps<0.5mm

OPTICAL RATINGS:

- Brightness: 1000 NITS
- View Angle: Horizontal 120°/Vertical 120° @ 13 ft. (4m)
- Gray Scale / Display Color: 14-bit
- Brightness Adjustment: 0~100% 100 Levels
- Processing: 14-bit

POWER SUPPLY:

- Operation Power: 100~240V 50-60Hz
- Max. Power Consumption: 170W/per panel
- Ave. Power Consumption: 70W/per panel
- Connections Power/Data: Power-PowerCon In/Out; Data EtherCon In/Out

ENVIRONMENTAL:

- Operating Temp / Humidity: Fahrenheit: -4° + 104° / Celsius: -20 + 40° / 10-90% (No Condensation)
- Operating Life / MTBF: 50,000 Hours / 5,000 Hours
- Protection Level: IP20 (Front and Back)
- Out of Control Rate: <0.02%
- Listings: ETL, CE, FCC Class A



ADJ TOURING CASE 8X AV3

1521000305

- Fits 8 AV3 video panels
- 9mm Plywood
- Butterfly Latches
- Swivel Castors



AV3FWA

1226300059

- Rear Support Bracket for AV3 Video Panels

AV3RBI Rigging Bar

1226300057

- Single panel rigging bar for AV3
- Up to 15 panels max vertical hang



NEW!

1226300054

AV6X

SPECIFICATIONS:

- Pixel Pitch: 6.0mm (0.25")
- LED Configuration: 3-in-1 SMD2121 LED
- Pixel Density: 96x96; 27,777 per square meter
- For indoor use only
- Size: 576 x 576 x 75mm / 22.75" x 22.75" x 3"
- Module Quantity: 4
- Weight: 23lbs. / 8.15Kg
- ETL Approved

MECHANICAL RATINGS:

- Surface Flatness: Gaps<0.5mm

OPTICAL RATINGS:

- Brightness: 1200 NITS
- View Angle: Horizontal 140°/Vertical 140°
- Distance: 20ft (6m)
- Gray Scale / Display Color: 14Bit
- Brightness Adjustment: 0~100% 100 Levels
- Processing: 14Bit

POWER SUPPLY:

- Operation Power: 100~240V 50-60Hz
- Max. Power Consumption: 300W/per panel
- Ave. Power Consumption: 120W/per panel
- Connections Power/Data: Power-PowerCon In/Out; Data EtherCon In/Out



ENVIRONMENTAL:

- Operating Temp / Humidity: Fahrenheit: -4° + 104° / Celsius: -20°

- + 40° / 10-90% (No Condensation)
- Operating Life / MTBF: 100,000 Hours / 5,000 Hours
- Protection Level: IP20 (Front and Back)
- Out of Control Rate: <0.02%
- Listings: CE, FCC Class A, RoHS, China RoHS, ETL

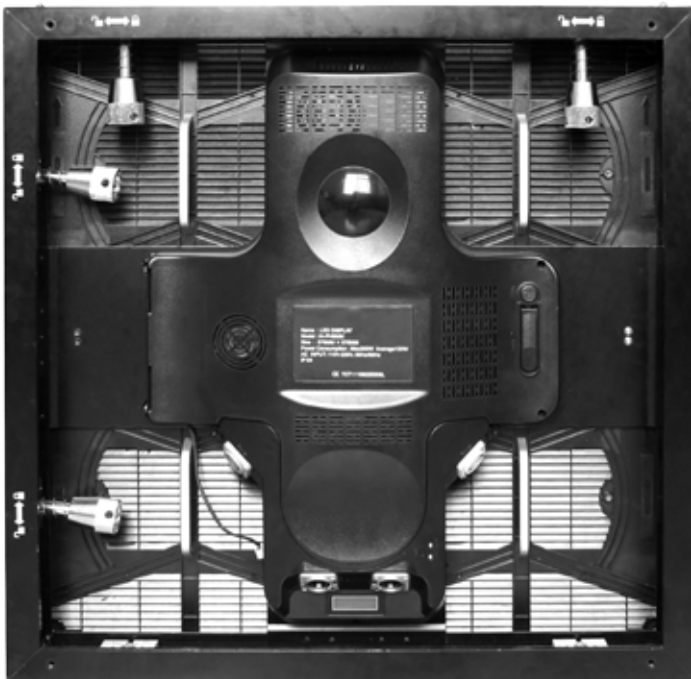

AV6RB2 Rigging Bar.

- Single panel rigging bar for AV6X
- Up to 20 panels max vertical hang



1226300053

ADJ TOURING CASE 8X AV6X

- Fits 8 AV6X video panels
- 9mm Plywood
- Butterfly Latches
- Swivel Castors
- Outer dimensions (LxWxH): 39.8" x 26" x 32.3" (1.01 x 0.66 x 0.82m)



1521000306

NEW!

Novastar VX4S

Video Processor/Switchers/Scaler

1226300067

CONTROL SYSTEM:

User Friendly LED Display Controller

Screen Configuration via on board menu system- No Computer needed.

Built In Scaler

Video Input: (1) DP / (1) HDMI / (2) VGA / (1) DVI / (2) CVBS / (1) SDI

(4) RJ45 Outputs for up to 2.35 million Pixels of LED Control

(2) USB Type A and (2) USB Type B Ports (1 set on each side)

Up to 1920 x 1200 p @60Hz Input Resolution

Multiple Video Signal Format Support

Cascade Multiple Units Together Via USB

19 inch/1U Rack Mountable

Weight: 5.6 lbs. (2.55 kg)

INCLUDED CABLES DP, VGA, USB, HDMI, DVI, CAT5, Power



MCTRL300

Video processor

1226300034

CONTROL SYSTEM:

Control Method: USB Interface Via Novastar LCT MARS (PC) & Novastar SmartLCT (MAC)

Frame Update Frequency: 50-60Hz

Refresh Rate: 1200Hz

(2) RJ45 Outputs for up to 1.3 million Pixels of LED Control

Video Interface: DVI

Control Distance: Ethernet Cable <100m or Fiber Optic>120m

Supported Modes: 1280 x 1024, 1024 x 1200, 1600 x 848, 1920 x 712, and 2048 x 668

Brightness Correction: Pixel, Module, Cabinet

Requires a computer (sold separately)

AV PRODUCT ACCESSORIES

First Data Cable

Product Code	Description
1226300039	CAT6S 7,5m AV6 FIRST CABLE
1226300040	CAT6S 15m AV6 FIRST CABLE
1226300041	CAT6S 30m AV6 FIRST CABLE



Data Link Cable

Product Code	Description
1226300048	CAT6 CBL 0,9m
1226300047	CAT6 CBL 1,5m
1226300046	CAT6 CBL 3m
1226300045	CAT6 CBL 4,5m
1226300044	CAT6 CBL 7,5m
1226300043	CAT6 CBL 15m
1226300042	CAT6 CBL 30m



Power Link Cable

Product Code	Description
1621000061	PLC1 0,3m
1621000027	PLC3 0,9m
1621000028	PLC6 1,80m
1621000029	PLC10 3,00m
1621000030	PLC15 4,50m
1621000062	PLC25 7,5m



First Power Cable

Product Code	Description
1239100270	Power Con -Schuko 3,0m
1239100268	Power Con -Schuko 7,5m
1239100267	Power Con -Schuko 15m





MOVING HEADS



1237000131

NEW!
VIZI HYBRID I6RX



Features

- Frost Filter
- Motorized Zoom
- Beam
- Spot
- Wash
- Rotating 6-facet & 8-facet prisms
- Rotating/Interchangeable gobos

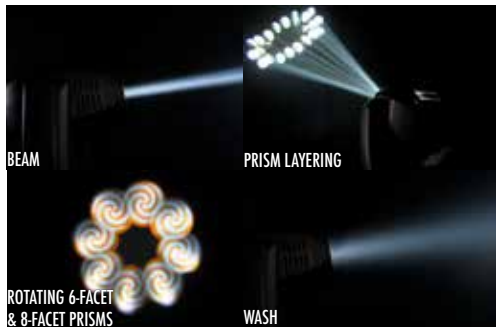

Technical Information

Optical:

- Light Source: Philips- Platinum 16R MSD
- Color Temperature: 8000K
- Life Expectancy: 1,500 Hrs.
- Beam Angle: 3-32 deg. Beam angle

Control

- Control Protocol: DMX 512
- DMX Channels: 19 DMX CH
- DMX Modes: 1 mode
- On Board: LED DMX 4-Button Menu

Specification:

- Pan & Tilt Range: pan 360-tilt 270
- Colours: 14 colors plus white
- Gobos: 2 separate wheels 1 (17 static plus spot 2) 12 replaceable
- Dimming: electronic 0%-100%
- Shutter: motorized
- Zoom: motorized
- Frost: frost filter & wash effect
- Prism: 6 & 8 facet w/macros, rotating & morphing
- Strobe: electronic
- Weight 51lbs. / 23kg
- Dimensions (LxWxH) 12.75 x 14.5 x 22.5 - 325x370x571mm

Electrical

- Input Voltage: 537 watts
- Power Draw @ 120V: 5.2amps
- Power draw @ 220V: 2.44 amps

Certifications

- Certifications: ETL Pending
- IP Rating: IP20

Whats Included

- (2) omega clamps
- (1) Powercon to Edison

Connections

- Power Input: Powercon
- Power Pass through: Powercon to Powercon
- Data: 3& 5 pin DMX

ADJ Touring Case 2x Vizi Hybrid I6RX

- Flight Case for 2 x Vizi Hybrid 16RX



PHOTOMETRICS

32°(LUX)	0	11950	2025	940	569
3°(LUX)	0	754000	161000	81000	47300

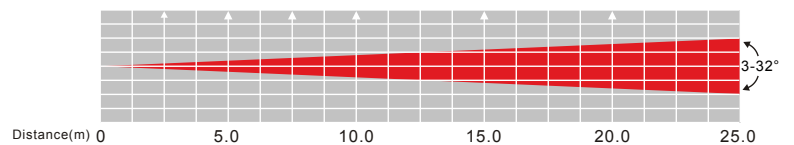

1237000167



NEW!
VIZI BSW 300

Features:

- Dual Color Wheels
- Dual Rpsisms
- Frost Filter
- Rotating/Replaceable Gobos
- Gobo Index
- Motorized Zoom/Focus
- Pan/Tilt Lock
- Beam
- Spot
- Wash



Technical Information:

Optical:

- Light Source: 300W White LED
- Beam Angle: 10 ° to 23 ° (Spot Mode)
- Beam Angle: 1 ° to 7 ° (Beam Mode)
- Beam Mode: 23 ° (Wash Mode) Frost Filter
- Lux at 3M; Lux at 5M Photometrics, in Beam Mode
- Lux at 3M; Lux at 5M Spot Mode
- Lux at 3M; Lux at 5M Wash (With Frost Filter)

Electrical

- Input Voltage: 100-240V 50Hz/60Hz (Auto Sensing)
- Power draw 120V 60Hz: 345W, 2.88 Amps
- Power draw 220V 50Hz: 345W, 1.57 Amps

Certifications

- ETL, UL, CE
- IP 20, Dry Area, No liquids

Specification:

- Pan/Tilt Range: 540 °/270 °
- Color Wheel 1: 7+ Open
- Color Wheel 2: 7+ Open (CTO 3200k), CTC (5600k)
- Gobo Wheel 1: 6 Fixed + Open (3 Beam Reducers Beam Mode)
- Gobo Wheel 2: 7 Rotating/Replaceable + Open (6 Glass, 1 Metal)
- Dimming: Electronic
- Shutter: Electronic
- Zoom: 10 ° to 20 ° (Spot Mode)
- Focus: Motorized
- Frost: 23 °
- Prism 1: 6 Facet Rotating Circular
- Prism 2: 6 Facet Rotating Linear

Whats Included

- PowerCON Cable
- Qty: 2 Omega Clamps
- Safety Cable
- Manual

ADJ Touring Case 2x Vizi BSW 300

- Flight Case for 2 x Vizi BSW 300



Connections:

- Power Input: PowerCON
 - Power Pass through: PowerCON
- PowerCON- @ 120V or 220V





VIZI BEAM 5RX

1237000119



NEW!
VIZI BEAM RXONE

1237000146



Specification

- Light Source: Philips® MSD Platinum 5R discharge, 8,000 ° K – 3,000 hr. long life
- 2 DMX Channel Modes: 16 or 19 DMX channels
- Beam Angle: 5-degree
- 14 colors + white and Split Colors
- 17 static, fixed gobos + spot
- 8-facet Prism with macros
- Motorized focus
- Frost filter for wash effect
- Gobo Shake effect
- Independent gobo and color wheels
- Powercon In/Out to daisy chain power 3 @ 120V, 6 @ 230V
- Multi-voltage Operation: 100-240V, 50Hz/60Hz
- Dimensions (LxWxH): 394x325x522mm / 15.5" x 12.75" x 20.5"
- Weight: 19 kg. / 42 lbs

Specification

- Osram® Sirius HRI 1R Discharge
- Colour Temperature: 9,000 °K
- Life Expectancy: 6,000Hr. Long Life
- Beam Angle: 3-Degree Beam Angle
- Pan & Tilt Range: PAN 540/360-degree / Tilt 270-degree
- Colours: 14 Colours + White and Spit Colours
- Gobos: 15 static, fixed gobo + spot
- Dimming: Electronic 0%-100%
- Frost: 21 degree filter
- Prism: 16 facet prism rotating
- Strobe: pulse effect, random strobe (slow-fast)
- Operational Modes: DMX, Sound Mode, Show Mode, Master/Slave
- Dimensions: LxWxH 11"x8.75x15.25 / 279mm x 225mm x 387mm
- Weight: 20lbs/ 9.2kgs
- Power Input: Power Con
- Power Pass through: PowerCon to PowerCon Link up to 8 Fixtures Max @120V
- Data: 3 Pin DMX 512
- DMX Channels: 15-17 ch / DMX Modes: 2 modes
- Remote Control: Optional UC IR, Airstream IR & Airstream DMX
- On Board: 4 Button Menu System
- Input Voltage: 100-240V, 50HZ/60HZ
- Power draw @120V: 1.6 amp, @220V: 9 amp
- Power Consumption: 199 Watts
- Certifications: ETL Pending
- IP Rating: IP20 - Dry Area, No Liquids
- ADJ Touring Case 4x Vizi Beam RXONE compatible

Photometric

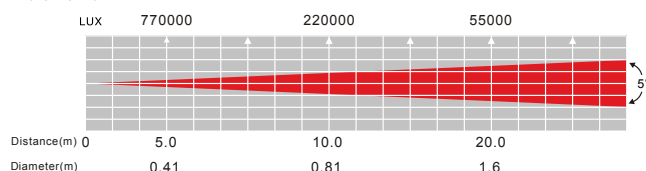

Photometric

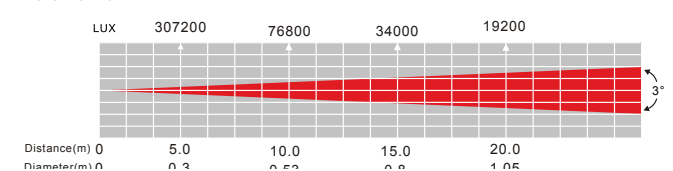



NEW!
VIZI Q WASH7

1237000166



NEW!
VIZI HEX WASH7

1237000165



Specification

- Light Source: 7 x 40W RGBW Quad Led
- Life Expectancy: 50,000 Hrs Led
- Beam Angle: 5-55 Degree
- Pan & Tilt Range: 630-degree/ Tilt 270-degree
- 64 Built in Color Macros
- Dimming: Electronic
- Shutter: Electronic
- Zoom: Motorized
- Motorized Zoom from 5° - 55°
- Operational Modes: 2 Modes Program / DMX
- Flicker Free: Yes
- Dimensions: (LxWxH): 11.75" x 8x15.75"/300x200x400mm
- Weight: 19lbs/8.5kgs
- Power Input: Power Con
- Power Pass through: Nuetrick power con in-out
- Data: 3 & 5 Pin in-out DMX
- Control Protocol: DMX
- DMX Modes: 2
- On Board: LCD Menu with 180 Inverse
- Input Voltage: 305W V.50Hz/60Hz
- Power draw @ 120V: 2.54 amp
- Power draw @ 220V: 1.39 amp
- Certifications: ETL Pending
- IP Rating: IP20 - Dry Area, No Liquids

Specification:

- Light Source: 7 (15) Watt Hex RGBWA+UV LED
- Life Expectancy: 50,000 Hrs Led
- Beam Angle: 5-55 Degree
- Pan & Tilt Range: 630-degree (540 Optional)/ Tilt 270-degree
- Colours: 64 Built in Macro
- Dimming: Electronic
- Zoom: Motorized 5° - 55°
- Dimmer Curves: 5 Dimmer Curves
- Operational Modes: 2 Modes Program / DMX
- Flicker Free: Yes
- Dimensions: (LxWxH): 11.75" x 8x15.75"/300x200x400mm
- Weight: 19lbs/8.5kgs
- Power Input: Power Con
- Power Pass through: Nuetrick power con
- Data: 3 & 5 Pin in-out DMX
- DMX Modes: 2
- On Board: LCD Menu with 180 degree Inverse
- Input Voltage: 100-230V, 50Hz./60Hz
- Power draw @ 120V: 137W
- Power draw @ 220V

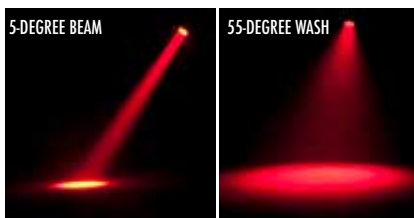
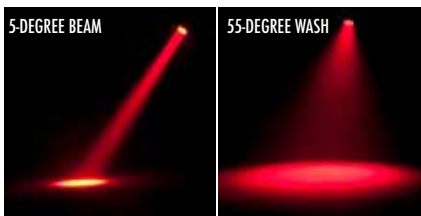



INNO COLOR BEAM Z19

1237000083



INNO COLOR BEAM Z7

1237000084



Specification

- Light Source: 19X 10w High Output Osram Ostar LED; 50,000 Hour Lamp life
- Illuminance (lux): 29500 @ 2M Full on 10°; 2,000 @ 2M Full on 60° Beam Angle
- Operational modes: DMX, Auto Run, Master/Slave & Sound Active
- DMX channels: 14; 3 & 5 Pin In/Out
- Features: Motorized zoom from 10° to 60°, Stepper Motors w/Micro stepping
- Pan: 540 degree, Tilt: 220 degree
- Power Con AC In/Out (Power daisy chain 5 units @110V, 11 units @220V)
- Power Draw: 245W Max; 2.23 Amps @ 110V; 1.11 Amps @ 220V
- Multi-voltage Operation: 100-230V, 50Hz/60Hz (auto sensing)
- Dimensions (LxWxH): 13" x 7.5" x 15.75"/ 329 x 188 x 395mm
- Weight: 21 lbs/ 9.5 kg

Specification

- Light Source: 7X 10w High Output Osram Ostar RGBW LED; 50,000 Hour Lamp life
- Illuminance (lux): 12700 @ 2M Full on 10°; 980 @ 2M Full on 60° Beam Angle
- Operational modes: DMX, Auto Run, Master/Slave & Sound Active
- DMX channels: 14; 3 Pin In/Out
- Features: Motorized zoom from 10° to 60°, RGBW Color mixing, Stepper motors
- Pan: 540 degree, Tilt: 220 degree
- IEC AC In/Out (Power daisy chain 4 units @110V, 8 units @220V)
- Power Draw: 104W Max; .95 Amps @ 110V; .47 Amps @ 220V
- Multi-voltage Operation: 100-240V, 50Hz/60Hz (auto sensing)
- Dimensions (LxWxH): 10.5" x 6.75" x 13.5"/ 262 x 167 x 340mm
- Weight: 17 lbs/ 7.5kg

RGBW Color Mixing:



RGBW Color Mixing:



Photometric

Beam Angle 10°	R	8500	4200	1700	970	620	(LUX)
	G	26000	10800	5000	2700	1700	
	B	8800	380	160	90	63	
	W	31500	14000	6000	3300	2100	
	RGBW	65000	29500	12600	6900	4400	
	Spot Diameter	36	54	70	95	110	(CM)
Beam Angle 60°	R	1000	2800	130	84	55	(LUX)
	G	3000	800	380	220	140	
	B	1100	31	16	10	8	
	W	3600	951	460	250	170	
	RGBW	7200	2000	900	540	360	
	Spot Diameter	170	300	440	580	750	(CM)

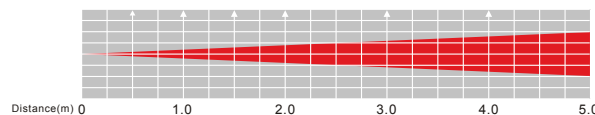

Photometric

Beam Angle 10°	R	7600	1700	917	500	328	(LUX)
	G	19600	5300	2300	1340	830	
	B	690	202	99	61	47	
	W	21800	6100	2680	1490	150	
	RGBW	47500	12700	5000	3200	1950	
Beam Angle 60°	R	610	200	87	55	42	(LUX)
	G	1500	430	204	125	86	
	B	73	32	25	21	17	
	W	1680	480	217	132	91	
	RGBW	3680	980	440	265	160	

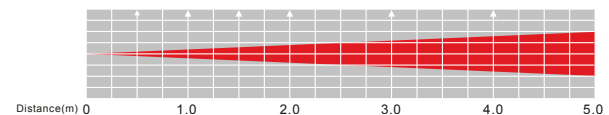



INNO POCKET Z4

1237000121



The Inno Pocket Z4 is a mini ZOOM Moving Head that creates beautiful washes of color with its 10-60-degree beam angle. Its compact size and lightweight makes it ideal for mobile entertainers, small club and bars, roller rinks, bowling centers, churches or any mobile production.

Featuring 4 x 10W 4-IN1 Quad LEDs (RGBW - Red, Green, Blue and White), the Inno Pocket Z4 will give pure lighting excitement with its fast moving head and brilliant washes of color. It has a pan and tilt inversion mode that makes one head do the opposite of another when linked together.

Users may control the Inno Pocket Z4 by Sound activation with its 4 built-in shows, the optional UC IR wireless remote, or use a DMX controller to create your own light shows.

Specification

- Light Source: 4 x 10W 4-in-1 RGBW LED source
- 3 Operational modes: DMX, Sound Active & Internal Show control modes
- 3 DMX Channel Modes: 16/19/22
- 4 Built-in shows
- Beam Angle: 10 - 60-degrees
- 5 selectable Dim Curves (Standard, Stage, TV, Architectural & Theatre)
- Optional IR wireless remote control (ADJ UC IR Not Included)
- Power consumption: 67W (Full-On)
- Multi-voltage Operation: AC 100 - 240V, 50/60Hz
- Dimensions (LxWxH): 5.5" x 6.75" x 9.75" / 141 x 174 x 247mm
- Weight: 7 lbs. / 3.2 kgs.

RGBW Color Mixing:



Photometric

Beam Angle 60°	R	322	92	52	35	27	(LUX)
	G	840	229	113	72	52	
	B	46	20	17	15	13	
	W	846	233	116	73	52	
	RGBW	1885	541	261	153	102	

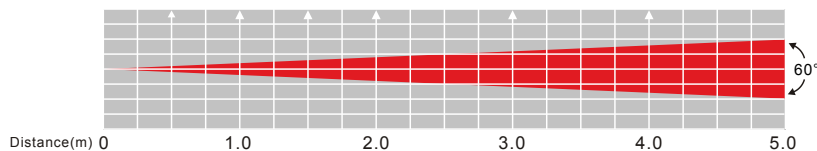

UC-IR
(Sold Separately)
1321000074



AIRSTREAM IR
1226100319



ILLUSION DOTZ 4.4

1223200033



ILLUSION DOTZ 3.3

1223200034



Specification

- Light Source: 16 X 30W RGB COB LEDs, 100,000 Lamp life
- Operational modes: DMX, Master/Slave Mode, Auto Mode & Sound Active
- DMX channels: 12, 14, or 59; 3 & 5 Pin In/Out
- Electronic Dimming: 0 - 100%; LED pulse and strobe effect
- Moving Head with 4X4 Matrix of Pixel controllable Tri color LEDs
- RJ45 Input/Output for Artnet/KlingNet Control
- Beam Angle: 15 degrees
- Powercon AC IN/OUT; Daisy Chain up to 3 units @120V, 5 units @ 220V
- Power Draw: 468W Max; 3.9 Amps @120V, 2.13 Amps@220V
- Multi-voltage Operation: 100-240V, 50Hz/60Hz (auto sensing)
- Dimensions (LxWxH): 16.5" x 6" x 15" / 414 x 153 x 376mm
- Weight: 33 lbs. / 15 kg.

Specification

- LED Source: 9 x 30W TRI RGB COB LED
- 3 Operational modes: DMX Control, Sound Active & Auto Show
- Editable Programs and Scenes
- 3 DMX Modes: 12/14/38
- Beam Angle: 15-degrees
- 5 selectable Dim Curves (Standard, Stage, TV, Architectural & Theatre)
- Stand Alone or Master-Slave Configuration
- IEC AC IN/OUT on rear to daisy chain power (up to @ 120V and @ 230V)
- ArtNet/Kling Net Protocol
- Power consumption: 285W (Full-On)
- Multi-voltage Operation: AC 100 - 240V, 50/60Hz
- Dimensions (LxWxH): 15" x 10.5" x 20.25" / 380 x 264 x 512mm
- Weight: 29 lbs. / 13 kgs.

RGB Color Mixing:



RGB Color Mixing:



Photometric

	R	9160	4090	2020	1280	832	
Beam Angle	G	11610	4850	2480	1580	1036	
15°	B	16700	6730	3530	2060	1470	(LUX)
	RGB	47700	19200	9700	5410	3540	
	Spot Diameter	0.26	0.53	0.79	1.05	1.32	

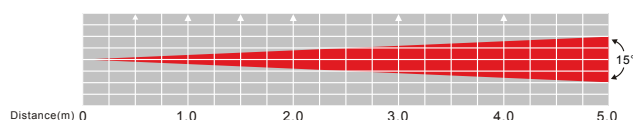

Photometric

	R	6680	2700	1430	730	483	
Beam Angle	G	8340	3140	1680	1100	593	
10°	B	11920	4400	2300	1450	829	(LUX)
	RGB	22900	9280	4600	2810	1920	
	Spot Diameter	0.40	0.75	1.10	1.50	1.75	

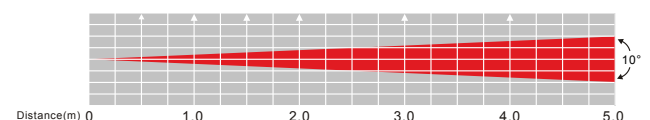



NEW!
FOCUS SPOT THREE Z/PEARL

Features:

- 100W motorised focus & zoom
- 2 (6) facet prisms
- Replaceable gobo
- Variable beam angle

Technical Information:

Optical:

- Light Source: 100w led (cool white led)
- Life Expectancy: 50,000hrs on led
- Beam Angle: 12-18 degree
- Illuminance (lux):@3m 13090

Specifications:

- Pan & Tilt Range:630 degree; Tilt 270 degree
- Colors: 8 color + spot
- Gobos: 2 gobos wheels 7 static + spot, 6 rotating, interchangeable gobo
- Dimming: Electronic
- Shutter: Motorized
- Zoom: Motorized zoom 12-18 degree
- Focus: Motorized
- Prism: 2 6 facet prism circular & linear
- Operational Modes: 3 modes, Sound, Show, Dmx
- Flicker Free
- Dimensions (L&W&H): 7.25" x 11.25" x 19.75" / 183x 284 x 489MM
- Weight: 26lbs/12kgs
- Color - White Focus Spot 3 Z Pearl (optional)

Connections:

- Power Input: PowerCON
- Power Pass through: PowerCON,
- Powerlink: Up to 3 x FS3 @ 120 V/ 6 x FS3 @ 230V
- Data: 3 Pin DMX

Control

- DMX Channels: 18-21 DMX ch
- DMX Modes: 2 modes
- On Board: 4 Button Display

Electrical

- Multi Voltage Operation: 100-230V, 50Hz/60Hz
- Power draw @120V: 2.09amp
- Power draw @220V: 1.05amp

Certifications

- Certifications: ETL, CE, RoHS
- IP Rating: IP20 - Dry Area, No Liquids

Whats Included

- Omega Bracket
- Power Con



ADJ Touring Case
4x Focus Spot Three Z 1521000284

- Holds 4 Focus Spot Three Z/ Pearl

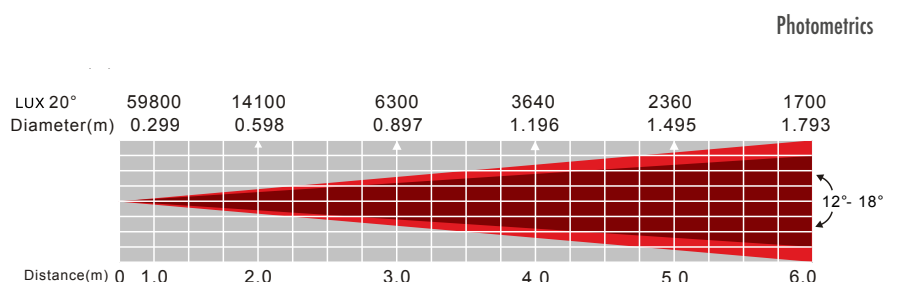

1237000147



NEW!

FOCUS SPOT TWO

Features:

- 75 Watt led with a 3 Watt UV Led
- Replaceable Gobos
- Manual Zoom

Ez Gobo Replacement



Colors / Gobos

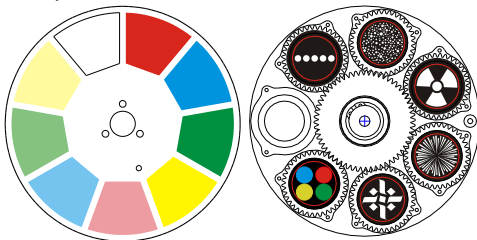

Technical Information:

Optical:

- Light Source: 75 Watt Led (Cool White Led) + 3watt UV LED
- Colour Temperature: 8000K
- Life Expectancy: 50,000hrs on led
- Beam Angle: 15 ° - 20 ° Manual
- Illuminance (lux): 8370 @ ft

Specifications:

- Pan & Tilt Range: 540 degree; Tilt 230 degree
- Colors: 8 Color + Spot Split Color
- Gobos: 6 Rotating Gobos + Spot
- Dimming: Electronic
- Shutter: Electronic
- Zoom: Manual 15-20 Degree
- Focus: Motorized
- Prism: 6 Facet
- Operational Modes: 3 Modes, Sound, Show, Dmx
- Dimensions (L&W&H): 6.75" x 9.25" x 15.25" / 173x 237 x 385MM
- Weight: 16lb./7.3kg

Connections:

- Power: PowerCON In/Out
- Nuetrirk PowerCON 14 FS2 @ 120 V + 26 FS2 @ 240 V
- Data: 3 Pin DMX

Control

- Control Protocol: DMX
- DMX Channels: 16-18 ch
- DMX Modes: 2 modes
- On Board: 4 Button Display
- Optional Controls: UC IR

Electrical

- Multivoltage operation: 100V-240V, 50hZ/60Hz
- Power Draw: 108W

Certifications

- Certifications: ETL, RoHS
- IP Rating: IP20 - Dry Area, No Liquids

Whats Included

- Omega Bracket
- Power Con Cable

Photometric

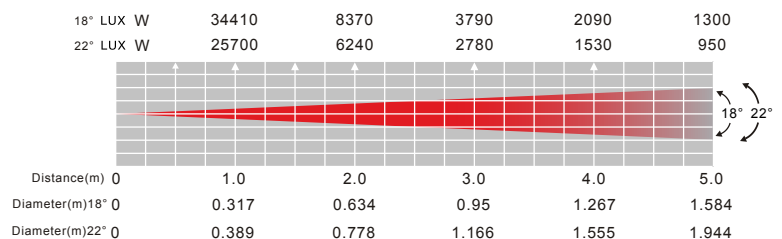

1237000157

NEW!
FOCUS SPOT ONE



Features:

- 35W Led moving head
- 3W UV Led
- Replaceable gobo
- Rotating and indexable gobo
- Motorised focus
- Compact and versatile

Technical Information:

Optical:

- Light Source: 35 Watt Led (Cool White Led) +3Watt UV LED
- Color Temperature: 8,000K
- Life Expectancy: 50,000 hrs
- Beam Angle: 16 Degree
- Illuminance (lux): 8370 @ 2m

Control:

- Data: 3 Pin DMX
- Control Protocol: DMX
- DMX Channels: 15-17 ch
- DMX Modes: 2 modes
- Remote Control: UC IR (Not Included)
- On Board: 4 Button Display
- Optional Controls: UC IR & Airstream

Specifications:

- Pan & Tilt Range: 540 degree; Tilt 240 degree
- Colors: 8 Color + Spot
- Gobos: 6 Rotating, Replaceable Gobos + Spot
- Dimming: Electronic 0%-100%
- Shutter: Electronic
- Focus: Motorized
- Dimmer Curves: 5 Dimmer Curves
- Operational Modes: 3 Modes, Sound, Show, Dmx
- Dimensions (L&W&H): 7.75" x 8.75" x 14.25" / 197x 221 x 360MM
- Weight: 12.5lb./5.7kg

Electrical

- Multivoltage: 100V-240V, 50Hz/60Hz
- Power draw 81W

Certifications

- Certifications: ETL, RoHS
- IP Rating: IP20 - Dry Area, No Liquids

Whats Included

- Omega Bracket
- Power Con Cable

Connections:

- Power: PowerCON In/Out

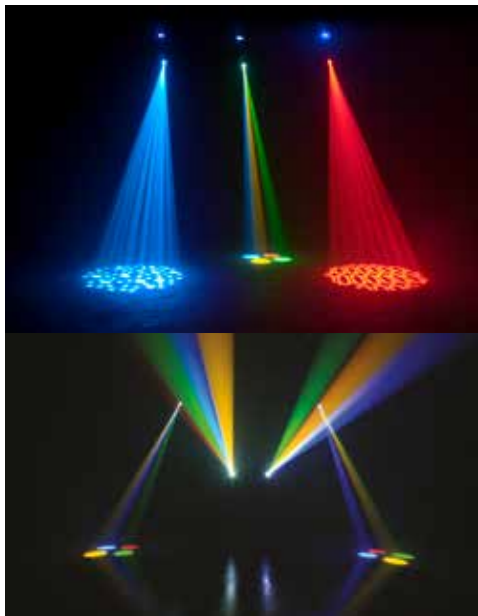

Colors / Gobos

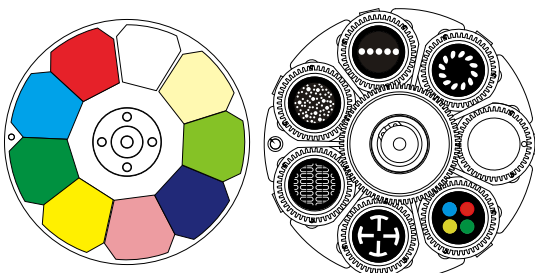

Photometric

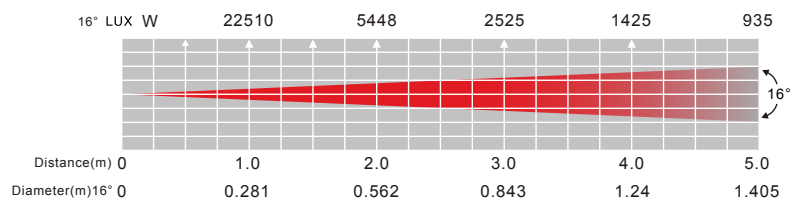



1237000088



1237000098

INNO POCKET SPOT/PEARL



INNO POCKET SPOT LZR

1237000139



Specification

- Light Source: 12W CREE High Output White LED, 50,000 Lamp life
- LUX: 4823 @ 2M at 13° beam angle
- Operational modes: DMX, Auto Run, Master/Slave & Sound Active
- DMX channels: 9 or 11; 3 Pin In/Out
- Colors: 7 Colors + White & Split Colors
- Gobos: 7 Fixed Gobos + spot
- Features: Built in Shows, IR remote control (Included)
- Pan: 540 degree, Tilt: 230 degree
- Power Draw: 53W Max; .44 Amps @120V, .21 Amps@220V
- Multi-voltage Operation: 100-240V, 50Hz/60Hz (auto sensing)
- Dimensions (LxWxH): 6.26" x 5.79" x 10.43" / 159 x 147 x 265mm
- Weight: 7 lbs. / 3 kg.



UC-IR (Included)
1321000074



AIRSTREAM IR
1226100319

Colors / Gobos

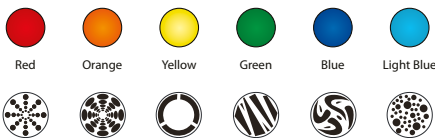

Specification

- LED Source: 12W White LED source (Rated at approximately 50,000 hrs)
- 7 Colors + white & Split Colors, 7 fixed gobos + spot
- Built-in Green Laser: 30mW (532nm) Green laser
- 3 Operational modes: DMX, Sound Active & Internal Show control modes
- 3 DMX channel modes: 13/14/16 Channels
- 540° pan / 200° tilt (16-bit) /Tilt Inversion mode
- 5 selectable Dim Curves (Standard, Stage, TV, Architectural & Theatre)
- Compatible with ADJ UC IR Remote (sold Separately) & Airstream IR
- Power consumption: 48W
- Multi-voltage Operation: AC 100 - 240V, 50/60Hz
- Dimensions (LxWxH): 6.25" x 5.75" x 10.75" / 159 x 147 x 271mm
- Weight: 7 lbs. / 3.4 kgs.



UC-IR
(Sold Separately)
1321000074



AIRSTREAM IR
1226100319

Photometric

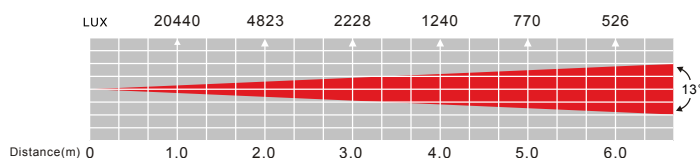

Photometric

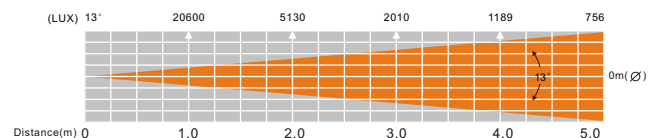



ASTEROID I200

1237000136



AIRSTREAM IR
1226100319

NINJA 5RX

1237000137

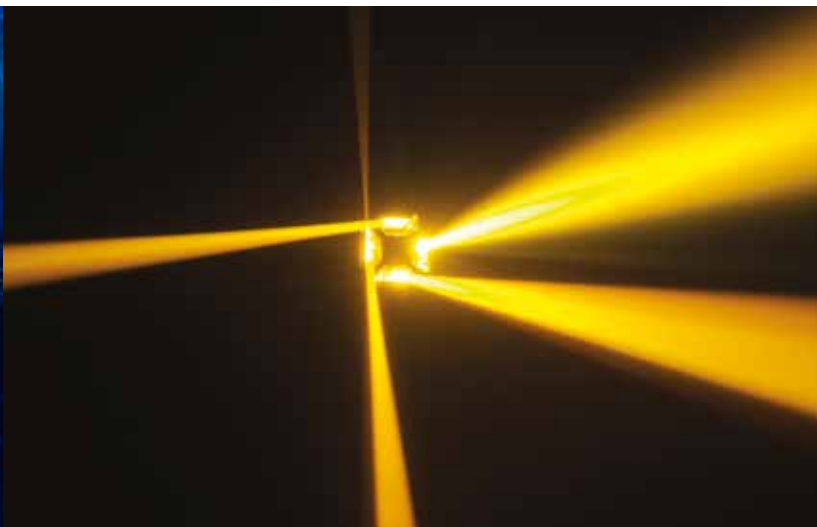

Specification

- Infinite Pan and Tilt rotation in both directions
- Advance lens optics eliminates RGBW shadows
- 4-degree beam angle produces sharp beams of light
- Pixel Mappable capability via DMX, Artnet or KlingNet
- Powercon Connections In and Out
- Light source: 12 X 15W RGBW (Red, Green, Blue, White) 4-IN-1 LED Engine
- Lamp Life: 50,000 Hrs
- Lux: 39,749 max; 9056 Full on @ 2M
- Beam Angle: 4-degree Fixed, 11-degree (Field Angle)
- Operational Modes: Artnet/KlingNet, DMX, Sound Active, Stand Alone, Master/Slave
- DMX Modes: 18, 20 or 64 Channels
- DMX Connection: 3-pin and 5-pin
- RDM compatible
- Strobe: Electronic 1Hz-20KHz
- Edit and save scenes into internal memory (9 programs with 64 steps, 250 scenes in total)
- Dimming: Electronic 0-100%, 5 selectable dimming curves
- Pan/Tilt: Infinite
- Power Connections: Powercon In / Powercon Out
- Power Draw: 226W Max/ Voltage Input: 100-240V, 50/60Hz
- Weight: 22Kg
- Dimensions 400 x 450 x 600mm

Photometric

R	13024	2836	1288	691	433	(LUX)
G	22173	3111	1976	1103	694	
B	3318	700	294	157	100	
WW	30095	5736	2406	1342	822	
RGBWW	39749	9056	3649	1957	1193	

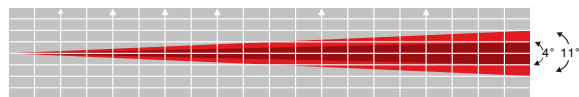

4° Diameter(m)	0	1.0	2.0	3.0	4.0	5.0
11° Diameter(m)	0	0.06	0.15	0.24	0.33	0.41
	0	0.19	0.37	0.54	0.72	0.89

Specification

- Light Source: Philips® MSD Platinum 5R discharge, 8,000 ° K - 3,000 hr. long life
- 3 Operating Modes: Show Mode (12 Shows), Sound Active Mode, & DMX Control
- 3 DMX Channel Modes: 1, 10, or 13 DMX channels
- Colors: 15 colors
- Gobos: 17 static, fixed gobos + open
- Independent gobo and color wheels / Tilt Invert / Built-In Tilt Macros / Shutter: Pulse effect; random strobe slow to fast / Mechanical Dimming: 0% - 100% / Strobe effect
- 4 high speed stepper motors with individual control
- Compatible with all UC IR wireless remote (sold separately), and Airstream IR
- Power Draw: 260W
- IEC in/out to Daisy Chain Power (Connect up to 2 fixtures max @ 120V, up to 5 fixtures max. @ 230V)
- Dimensions (LxWxH): 340x313x333mm / 13.25" x 12.25" x 13"
- Weight: 10 kg. / 22 lbs

Colors / Gobos

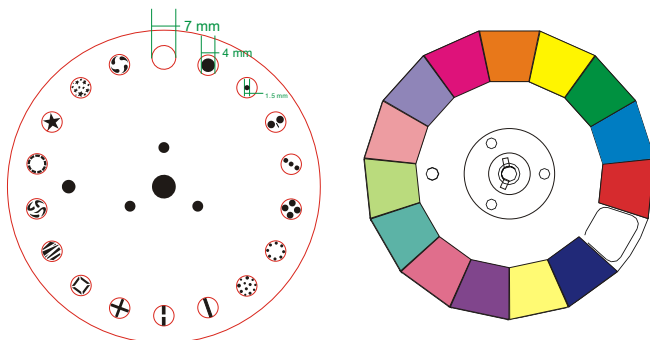



WARLOCK

123700011



KAOS



ADJ UC IR
(Sold Separately)
132100074



AIRSTREAM IR
1226100319

123700012



Specification

- Compact Barrel Mirrored Scanner with a bright Philips® Platinum MSD 2R source
- 3 Operational Modes: DMX control, Show Mode, & Sound Active
- 8 DMX Channels / 6 Built-in Programs
- 12 colors + white w/ Split Colors / 12 Fixed Gobo Patterns + Spot & Gobo Shake
- Reflector Rotation Mirror produces a 360-degree rotation
- Independent gobo and color wheels / Gobo scroll mode
- Beam Angle: 28 Degrees / 180° pan / 360° tilt continuous barrel rotation
- Shutter: Strobe & Pulse effect; random strobe slow to fast
- Mechanical Shutter dimming 0-100%
- Fan Cooled / Stepper motors with micro stepping
- Power consumption: 202W
- 3-pin XLR In/Out
- IEC AC IN/OUT to daisy chain power (up to 3 @ 110V and 6 @ 230V)
- Power consumption: 202W
- Multi-voltage Operation: 100-240V, 50Hz/60Hz
- Dimensions (LxWxH): 20.25" x 20.25" x 14" / 512 x 516 x 354mm
- Lamp: Philips® MSD Platinum 2R discharge 132W, 8,000 °K - 6,000 hr. average long life
- Weight: 22 lbs. / 10kgs

Photometric

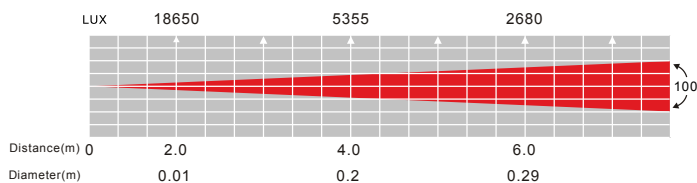

Specification

- Unique lighting fixture with quick sweeping narrow beams combined with an 3 x 3-Zone LED chase, continuous rotation in both directions
- 9 x 10-Watt RGBW Cree LEDs / 4-Button DMX LED Display
- 3 Operational modes: Sound Active, Show Mode, & DMX Controlled
- 5 DMX Channel Modes: 2/6/15/23/45 / Master/Slave Set Up or Stand Alone
- DMX-512 Protocol / Electronic Dimming: 0 - 100%
- Includes exciting sound active built-in programs / LED pulse & strobe effect
- 60 - 150 degree tilt from smooth Stepper Motors / 0 - infinite degree pan
- Beam angle: 5 Degrees
- Runs extremely cool! - NO Duty Cycles! - Run all night!
- Includes Omega quick lock brackets / Mount on a wall, trussing, or set on the ground
- PowerCon AC IN/OUT on rear to daisy chain power (up to 5 @ 120V and 9 @ 230V)
- Compatible with ADJ UC IR easy-to-use remote (sold Separately)
- Power Consumption: 140W maximum
- Multi-voltage operation: AC 100-240V 50/60Hz
- Dimensions (LxWxH): 18"x 17"x 8.25" / 458 x 423 x 186mm
- Weight: 23.3 lbs. / 10.6 kg.

Photometric

R	10086	7063	3443	2057	1343	(LUX)
G	36800	21420	9230	5682	3452	
B	64440	23820	9416	5302	2910	
W	54020	31400	13810	7750	4705	

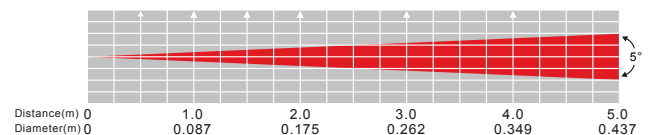



CRAZY 8

123700087



CRAZY POCKET 8

1237000141

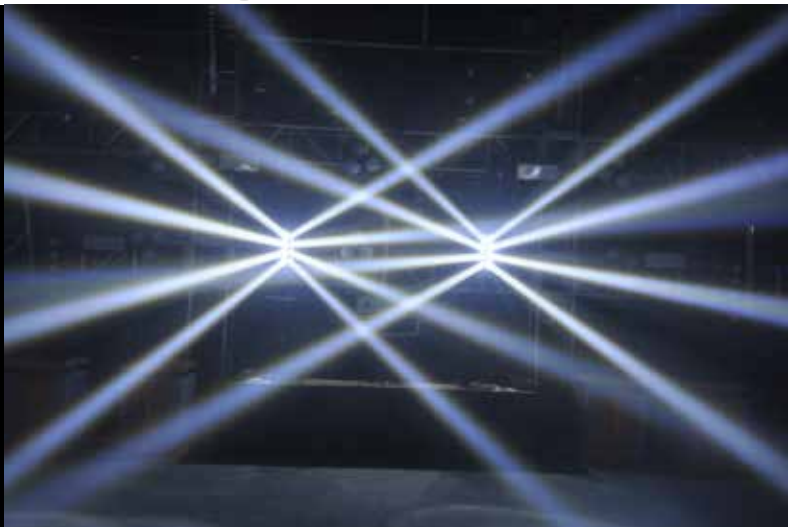

Specification

- Light Source: 8 X 8W High Powered White LEDs, 50,000 Lamp life
- Operational modes: DMX, Master/Slave Mode & Sound Active
- DMX channels: 1,9,12,15, or 21; 3 Pin In/Out
- Moving Head with dual tilting bars, create 8 sharp 4.5 degree beams
- Base Pan 540 degree, each bar Tilts 210 degrees
- Electronic Strobe/Random effect; Individual Pixel Control
- Powercon AC IN/OUT; Daisy Chain up to 4 units @120V, 8 units @ 220V
- Power Draw: 90W Max; .75 Amps @120V, .41 Amps@220V
- Multi-voltage Operation: 100-240V, 50Hz/60Hz (auto sensing)
- Compatible with ADJ UC3 series remotes
- Dimensions (LxWxH): 16.5" x 6" x 15" / 414 x 153 x 376mm
- Weight: 18 lbs. / 7.8 kg.

Compatible with UC3 Series

UC3 Universal Controller



Specification

- Light Source: 8x 3-Watt RGBA LEDs (2 Red, 2 Green, 2 Blue, & 2 Amber)
- 3 Operational modes: Sound Active Mode, Show Mode, & DMX Controlled
- 4 DMX Channel Modes: 1/9/17/21
- Moving Head fixture with quick sweeping 8-Zone RGBA LED chase Dual LED Bars, each with 4 lenses, move independently
- 540-degree base pan, 205-degree bar tilt from smooth Stepper Motors
- Electronic Dimming: 0 - 100% / LED pulse & strobe effect
- Beam angle: 4-degrees
- Power Consumption: 59W (All LED's @ Full On)
- Multi-voltage operation: AC 100-240V 50/60Hz
- Compatible with ADJ UC IR Remote (sold Separately) & Airstream IR
- Dimensions (LxWxH): 11.75" x 6" x 10.25" / 298 x 149 x 262 mm
- Weight: 8 lbs. / 3.5 kg.



UC-IR
(Sold Separately)
1321000074



AIRSTREAM IR
1226100319

Photometric

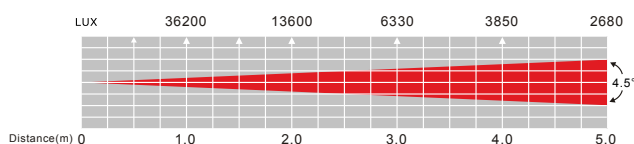

Photometric

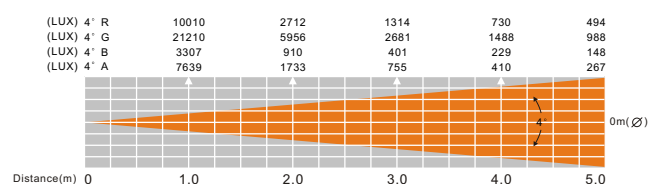



1237000082

SWEEPER BEAM QUAD LED



Specification

- Light Source: 8 x 8W High Output RGBW (Red, Green, Blue, White) LEDs
- Quick sweeping Beam effect with 270° tilt stepper motors and individual LED cell control
- Extremely sharp 3.5° beam angle;
- DMX Channel Modes : 1, 6, 35, 39
- LED pulse & strobe effect
- 270 degree tilt from smooth Stepper Motors
- 4-Button DMX LED Display
- 3 Operational modes: DMX controller, Master/Slave & Sound Active
- 3 PIN DMX In/Out
- IEC AC In/Out (Power daisy chain 8 units @110V, 14 units @220V)
- Power Consumption: .43 Amps @ 110V; .21 Amps @ 220V
- Dimensions (LxWxH): 38.5" x 3.0" x 5.25" / 973 x 73 x 132mm
- Weight: 13 lbs/ 6.3 kg

Compatible with UC3 Series
UC3 Universal Controller



1237000130

XS 600



Specification

- Unique dual Axis Moving Head with 360° continuous rotation, in both directions
- 3 Operational Modes: DMX control, Show Mode, & Sound Active
- 2 DMX Channel modes: 25 Channels & 31 Channels
- 6 x 10W 4-in-1 RGBW LEDs
- Pixel control of each LED
- Beam Angle: 10 Degree / 360° continuous rotation, in both directions
- Power consumption: 60W
- 3-pin XLR DMX connectors
- I.E.C. In & Out to Daisy chain Power (Connect up to 8 Fixtures)
- Multi-voltage Operation: AC 100-240V 50/60Hz I.E.C. In
- Dimensions (LxWxH): 7" x 7.75" x 12.5" / 180.2 x 195.6 x 317.7mm
- Weight: 7 lbs. / 3 kgs.



UC-IR
(Sold Separately)
1321000074



AIRSTREAM IR
1226100319

Photometric

R	11300	5782	2581	1455	848	(LUX)
G	17100	5272	2093	1120	672	
B	29900	7653	2713	1379	774	
W	15500	5331	2229	1242	740	

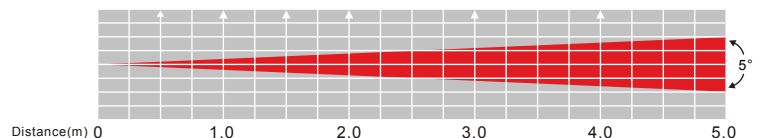



XS 400

1237000129



XS 200

1237000128



Specification

- Unique single Axis Moving Heads with 360° continuous rotation, in both directions
- 3 Operational Modes: DMX control, Show Mode, & Sound Active
- 2 DMX Channel modes: 16 Channels & 18 Channels
- 4 x 10W 4-in-1 RGBW LEDs
- Pixel control of each LED
- Beam Angle: 10 Degree / 360° continuous rotation, in both directions
- Power consumption: 40W total
- 3-pin XLR DMX connectors
- I.E.C. In & Out to Daisy chain Power (Connect up to 8 Fixtures)
- Multi-voltage Operation: AC 100-240V 50/60Hz- I.E.C. In
- Dimensions (LxWxH): 4.75" x 6.75" x 11.25" / 123.6 x 169.9 x 284.5mm
- 2.5 lbs. / 6 kgs.

Specification

- Single Axis Moving Head with 360° continuous rotation, in both directions
- 3 Operational Modes: DMX control, Show Mode, & Sound Active
- 2 DMX Channel modes: 16 Channels & 18 Channels
- 2 x 10W 4-in-1 RGBW LEDs
- Pixel control of each LED
- Beam Angle: 10 Degree / 360° continuous rotation, in both directions
- Power consumption: 20W total
- 3-pin XLR DMX connectors
- I.E.C. In & Out to Daisy chain Power (Connect up to 8 Fixtures)
- Multi-voltage Operation: AC 100-240V 50/60Hz- I.E.C. In
- Dimensions (LxWxH): 4.75" x 5.5" x 11.25" / 123.4 x 100 x 284.5mm
- Weight: 2 lbs. / 4 kgs



UC-IR
(Sold Separately)
1321000074



AIRSTREAM IR
1226100319



UC-IR
(Sold Separately)
1321000074



AIRSTREAM IR
1226100319

Photometric

R	11300	5782	2581	1455	848	(LUX)
G	17100	5272	2093	1120	672	
B	29900	7653	2713	1379	774	
W	15500	5331	2229	1242	740	

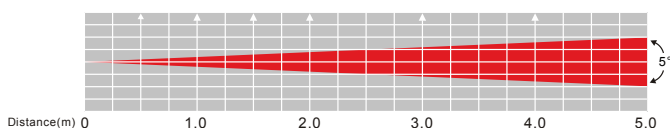

Photometric

R	11300	5782	2581	1455	848	(LUX)
G	17100	5272	2093	1120	672	
B	29900	7653	2713	1379	774	
W	15500	5331	2229	1242	740	

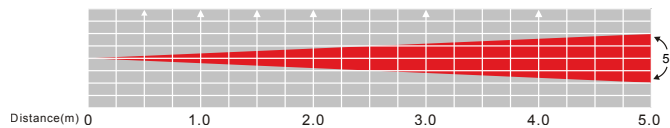

INNO ROLL HP

1237000091

Specification

- Light Source: 80W High Output White LED Engine, 50,000 Lamp life
- LUX: 2000 @ 2M at 10° beam angle
- Operational modes: DMX, Master/Slave & Sound Active
- DMX channels: 9 Channels; 3 Pin In/Out
- Colors: 8 Colors + Open + Split colors
- Gobos: 6 Rotating, Interchangeable Gobos + spot, 24mm (20mm viewable; metal)
- IEC IN/OUT; Daisy Chain up to 6 units @120V, 10 units @ 220V
- Power Draw: 103W Max; .86 Amps @120V, .47 Amps@220V
- Multi-voltage Operation: 100-240V, 50Hz/60Hz (auto sensing)
- Compatible with ADJ UC3 series remotes
- Dimensions (LxWxH): 22.75" x 11" x 8.25" / 578 x 278 x 209mm
- Weight: 14 lbs. / 6.4 kg.

Photometric

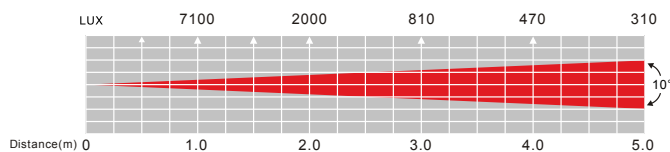

Colors / Gobos

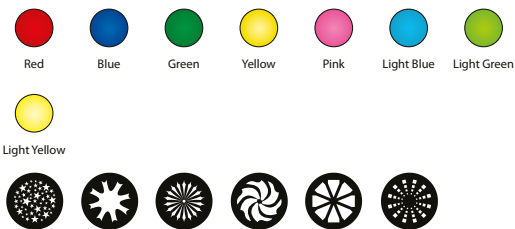

INNO SCAN HP

1237000090

Specification

- Light Source: 80W High Output White LED Engine, 50,000 Lamp life
- LUX: 5461 @ 2M at 16° beam angle
- Operational modes: DMX, Auto Run, Master/Slave & Sound Active
- DMX channels: 9, or 12; 3 Pin In/Out
- Colors: 8 Colors + Open + Split colors
- Gobos: 6 Rotating, Interchangeable Gobos + spot, 24mm (20mm viewable; metal)
- IEC IN/OUT; Daisy Chain up to 6 units @120V, 10 units @ 220V
- Power Draw: 103W Max; .86 Amps @120V, .47 Amps@220V
- Multi-voltage Operation: 100-240V, 50Hz/60Hz (auto sensing)
- Compatible with ADJ UC3 series remotes
- Dimensions (LxWxH): 22.75" x 11" x 8.25" / 578 x 278 x 209mm
- Weight: 16 lbs. / 7.3 kg.

Photometric

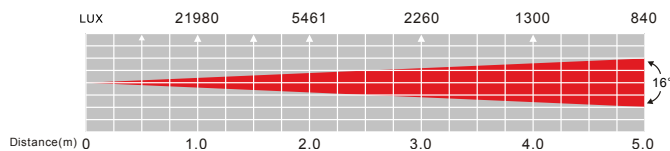

Colors / Gobos

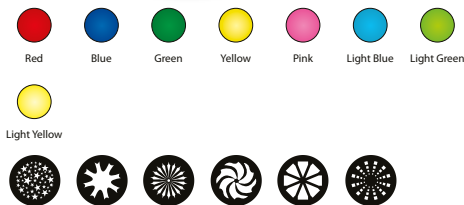

INNO SCAN HP

INNO ROLL HP



INNO POCKET SCAN

Specification

- Light Source: 12W White LED source (Rated at approximately 50,000 hrs)
- Flat Mirrored Scanner
- Single GOBO/Color wheel: 8 fixed GOBO/Colors + spot/white
- 3 Operational modes: DMX, Sound Active & Internal Show control modes
- 6 DMX channels / 12 Built-in shows
- 5 selectable Dim Curves (Standard, Stage, TV, Architectural & theatre)
- IEC AC IN/OUT on rear to daisy chain power
- Optional IR wireless remote control (ADJ UC IR Not Included)
- Power consumption: 33W (Full-On)
- Multi-voltage Operation: AC 100 - 240V, 50/60Hz
- Dimensions (LxWxH): 11.5" x 5.25" x 6.5" / 294 x 132 x 160mm
- Weight: 6 lbs. / 2.4 kgs.

Photometric

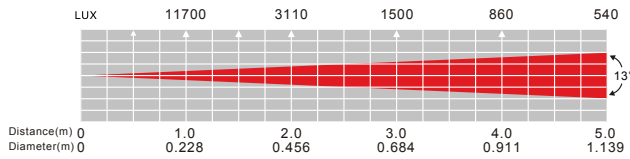

1237000102



UC-IR (Not Included)
1321000074



AIRSTREAM IR
1226100319



Colors / Gobos



INNO POCKET ROLL

Specification

- Light Source: 12W White LED source (Rated at approximately 50,000 hrs)
- Barrel Mirrored Scanner
- Single GOBO/Color wheel: 8 fixed GOBO/Colors + spot/white
- 3 Operational modes: DMX, Sound Active & Internal Show contr modes
- 6 DMX channels / 12 Built-in shows
- 5 selectable Dim Curves (Standard, Stage, TV, Architectural & Theatre)
- IEC AC IN/OUT on rear to daisy chain power
- Optional IR wireless remote control (ADJ UC IR Not Included)
- Power consumption: 36W (Full-On)
- Multi-voltage Operation: AC 100 - 240V, 50/60Hz
- Dimensions (LxWxH): 13" x 5.25" x 6.5" / 329 x 132 x 165mm
- Weight: 6 lbs. / 2.6 kgs.

Photometric

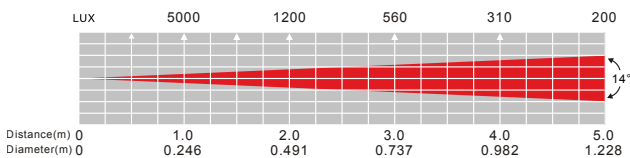

1237000103



UC IR (Not Included)
1321000074



AIRSTREAM IR
1226100319



Colors / Gobos



INNO POCKET ROLL



INNO POCKET SCAN



3D VISION

1226300060

NEW!



Technical Information:

- 3D LED Effect Panel. Use in multiples to create a dynamic
- Modular connecting system allows you to create different configurations
- Quick lock rigging system allows you to assemble and disassemble quickly
- 10mm thread on rear for standard Pro Clamp, truss mount
- Control Protocol: DMX512
- Data Connections: Ethernet, Input and Output
- Product Size: 15.8" x 15.8" x 2.7" (400 x 400 x 68mm)
- LED Quantity, per unit: 72pcs.
- LED Type: 5050 SMD, 3in1
- Power Connections: Powercon, Input and Output
- Max Power Consumption: 13W
- Input Voltage: 100-265VAC
- Net Weight: 6lbs. (2.74kg)
- Face Material: Frosted White Acrylic
- Viewing Angle: 180 - Degrees
- Working Temperature: -4 to 140F (-20 to +60 C)
- Working Lifespan: 50,000Hrs
- Includes one (1) data cable, one (1) Linking Cable and one (1) Safety Cable

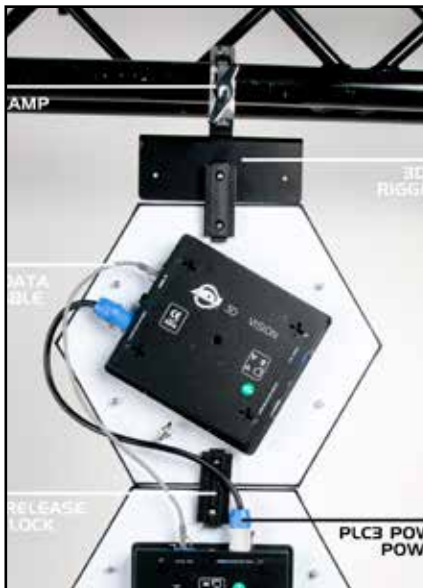

3D VISION ENCODER

1226300061



- 3D Vision DMX Address Encoder
- DC 9-12 Volt Battery Power or 120V
- Power Consumption: 1.5W (Max)
- Weight: 826lbs / 37kg
- Dimensions: (LxWxH): 2" x 4" x 5.25" / 50x 100 x 133mm

3D VISION PL

1226300063



3D Vision accessory that quickly locks/unlocks two panels together

3D VISION RBI

1226300062



Metal rigging bar for the ADJ 3D Vision Panels



ACRJ453PM

ACRJ453PM XLR to RJ45 Adapter
(connects myDMX 2.1 to 3D Vision)

1154000037



3D VISION SYS ONE

System Includes

- 5x3D Vision Panels (includes power linking cable & RJ45 linking cable)
- 1x myDMX 3.0 DMX Control Software
- 1x MPC10 powerCon Power Cord
- 1x ACRJ453PM XLR to RJ45 adapter (connects myDMX 3.0 to 3D Vision)

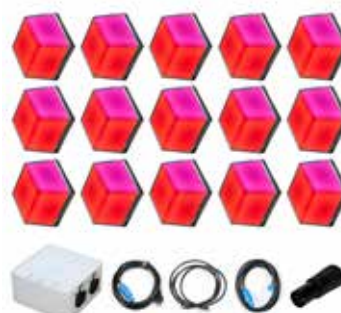

3D VISION SYS TWO

System Includes

- 15x3D Vision Panels (includes power linking cable & RJ45 linking cable)
- 1x myDMX 3.0 DMX Control Software
- 1x MPC10 powerCon Power Cord
- 1x ACRJ453PM XLR to RJ45 adapter (connects myDMX 3.0 to 3D Vision)

1226300029



FLASH KLING PANEL 64



Specification

- Light Source: 64 x SMD RGB LED's (8x8 Matrix Configuration)
- LED Pixel panel for, low resolution, video displays
- 120-Degree Beam Angle
- Operational Mode: KlingNet and ArtNet compatible. Recommended control solutions; Arkaos Media Master Express, Media Master Pro and LED Master software's (sold separately).
- Link up to 100 Flash Kling Panel 64's
- Power Connection: IEC AC In/out
- Power Consumption: 20W (Full On)
- Input Voltage: AC 100V-240V 50/60Hz
- Dimensions: 19.75" x 19.75" x 2.5" in. / 500 X 500 X 63mm
- Weight: 12 lbs / 5.6 kgs

Panel Lock for Flash Kling Panel 64 -Code: 1226300030

RGB Color Mixing:



1222300016



ULTRA KLING BAR18

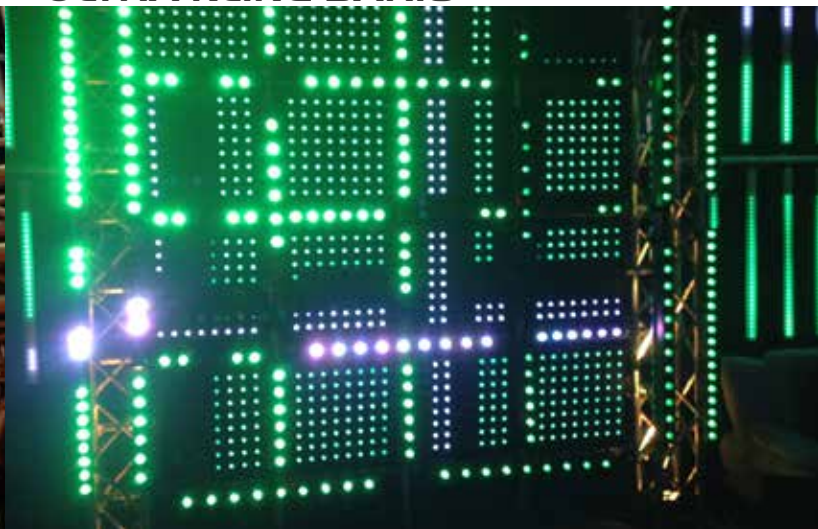

Specification

- Light Source: 18x 3W Tri LEDs Pixel Bar
- 5 Operational Modes: DMX, Sound Active, Auto, Kling Net, Master/Slave
- DMX Channel Modes: 3, 4, 6, 8, 9, 15, 54; 3-pin In/Out
- Built-In Programs & Color Macros
- RJ45 In/Out Kling Net & Art Net
- Electronic Dimming 0-100%
- Kling Net & Art-Net Control available
- Individual Pixel Control
- Power Consumption: 98W @ full on
- Power Connection: IEC AC In/out
- Input Voltage: AC 100V-240V 50/60Hz
- Dimensions: 43.5" x 3.25" x 4.5" in. / 1100 X 80 X 116mm
- Weight: 13 lbs / 6 kgs

RGB Color Mixing:



Photometric

R	712	318	161	105	67	(LUX)
G	696	283	147	85	52	
B	638	291	138	79	48	
RGB	1750	816	393	239	157	

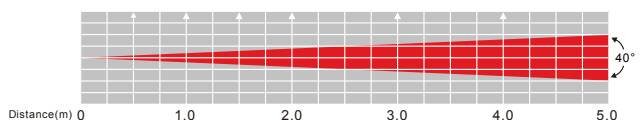



FLASH KLING BATTEN

1226200048

FLASH KLING STRIP

1226300051

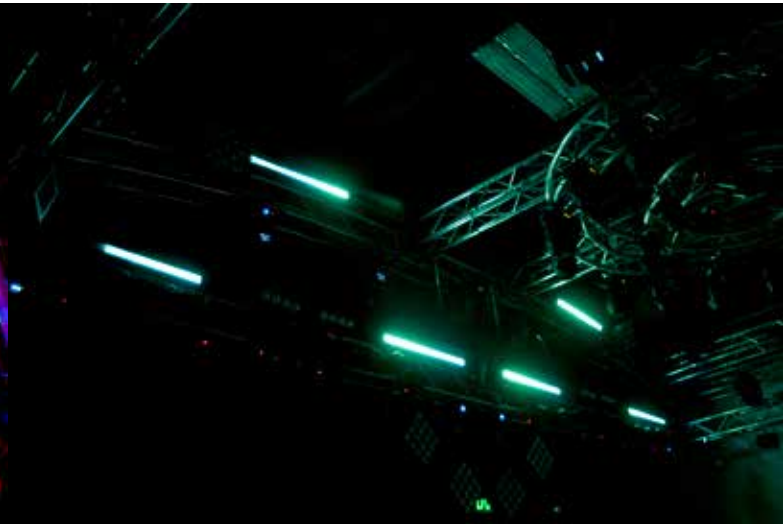
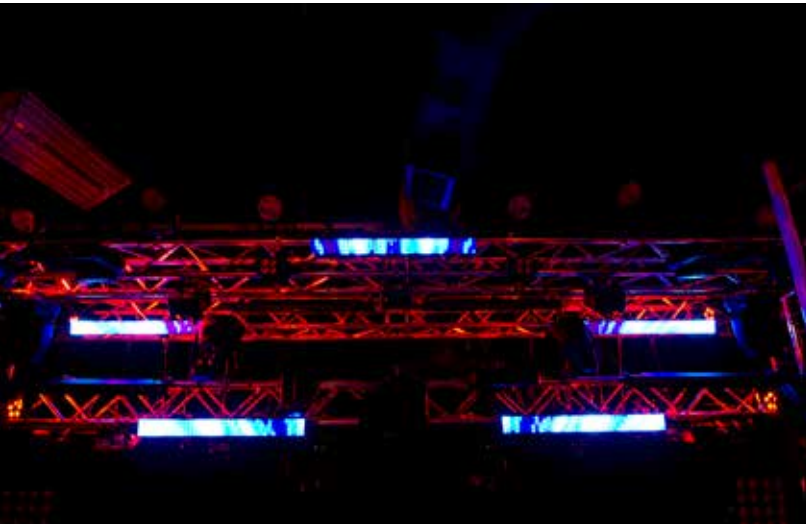

Specification

- LED Pixel panel for, low resolution, video displays
- 160 x 0.164W SMD RGB 3-in1 LED's (40x4 Matrix Configuration)
- 120-Degree Beam Angle
- KlingNet and ArtNet compatible. Recommended control solutions; Arkaos Media Master Express, Media Master Pro and LED Master software's (sold separately).
- RJ45 Connection
- Electronic Dimming 0-100% (via software)
- AC 100V-240V 50/60Hz
- Power Cord Daisy Chain up to 12 fixtures max.
- Power Consumption: 54W
- Dimensions (LxWxH): 39.25" x 4" x 5.5" / 1000 x 104 x 140mm
- Weight: 7.27 lbs. / 3.3 Kgs.

Specification

- 40 x 0.164W SMD RGB 3-in1 LED's (40x2 Matrix Configuration)
- LED Pixel panel for, low resolution, video displays
- 120-Degree Beam Angle
- KlingNet and ArtNet compatible. Recommended control solutions; Arkaos Media Master Express, Media Master Pro and LED Master software's (sold separately).
- RJ45 Connection
- Electronic Dimming 0-100% (via software)
- AC 100V-240V 50/60Hz
- Power Cord Daisy Chain up to 22 fixtures max.
- Power Consumption: 28W
- Dimensions (LxWxH): 39.25" x 2.25" x 5.5" / 1000 x 59 x 140mm
- Weight: 6 lbs. / 2.7 Kgs.

Photometric

R	115.2	22.4	8.2	4.8	3.6	2.1	(LUX)
G	153.7	36.6	12.4	8.6	4.5	3.8	
B	160	39.3	12.8	6.8	4.7	3.6	
RGB	405	108	36.2	21.7	13.5	9.6	

Photometric

R	77.2	21.2	5.5	2.7	1.6	1.1	(LUX)
G	85.5	27.4	7.6	3.6	2.1	1.4	
B	81.4	23.6	6.2	2.9	1.8	1.3	
RGB	211	76.5	18.8	9.2	5.5	3.8	

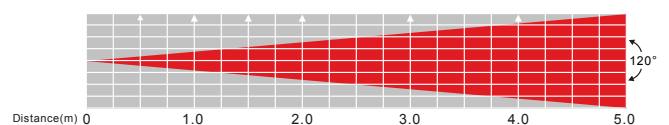
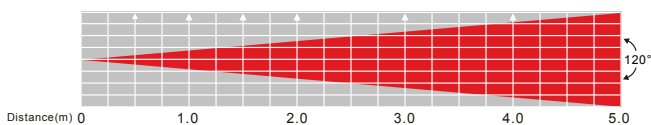

PIXEL KLING IOC

1211500010

Specification

- 10-Channel Pixel Tube Driver with KlingNet and DMX Protocols.
- Controls up to 10 Tubes
- 5 Operating Modes: RGB Dimmer Mode, Sound Active Mode, Auto Run Mode, Static Color Mode, & DMX Control
- 4 DMX Channel Modes: 5/7/32/480
- 8 Static Colors
- 49 Auto Run Shows: 24 Color Fade, 24 Color Change, 1 Fade & Change
- 24 Sound Active Shows
- Strobe: Slow - Fast
- Dimming 0% - 100%
- Display Brightness Control
- IEC AC IN/OUT Daisy chain power (up to 3pcs.)
- Optional IR Wireless remote (ADJ LED RC2 Not Included)
- Power Consumption: 200W
- Multi-Voltage Operation: AC 120V/60Hz or 240V/50
- Dimensions: (LxWxH): 12.75" x 11.25" x 3.25" / 318 x 280 x 80mm
- Weight: 10 lbs. / 4.5 kgs.



EZ KLING

1321000070

Specification

- RJ45 to DMX and RJ45 to Kling-Net interface
- Allows users to pixel map Kling-Net and DMX compatible fixtures through the Kling-Net mapper included in Media Master Express and Media Master Pro (Zeus)
- Ideal for use with Flex Pixel Tape and Pixel controllable DMX fixtures
- One EZ Kling interface will drive up to 600, Flex Pixel RGB pixels and 150 DMX Pixels
- 4-button LCD control menu
- Dimensions: (LxWxH): 5.5" x 5" x 1.75" / 135 x 125 x 41mm
- Weight: 2 lbs. / 0.7 kg.



LED MASTER (Klingnet Software)

1310000026

Specification

- Video control software for use with Kling-Net compatible LED fixtures
- Compatible with EZ-Kling box
- 3 Program Modes: Mapping mode; Scene Programming mode; Performance mode
- Mapping mode automatically recognizes Kling-net fixtures
- Scene programming mode allows for users to create scenes
- Performance mode allows for scenes to be triggered live
- Auto-configuring with a large range of fixtures



LED PIXEL TUBE 360

121150007

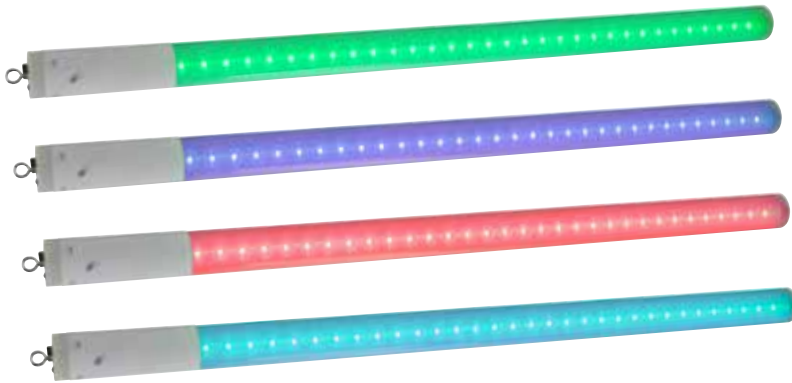

Specification

- 39.5-inch/ 1000mm TRI LED Color Tube with UV-resistant polycarbonate tubing
- 64 Bright TRI LEDs
- Built-in color macros (When using the LED Pixel 4C or Pixel Kling 10C Controllers)
- Long life LEDs (50,000 hr. rating)
- RGB Color Mixing
- Strobe & Pulse LED Effect
- Runs extremely cool! - NO Duty Cycles! - Run all night!
- Visible for 360 degrees
- Can only be used together with either LED Pixel 4C or Pixel Kling 10C controller
- Power input: DC 24V, 4-pin input power cable with female connector
- Power consumption: 15W per LED tube
- Dimensions (LxWxH): 39.5"x2"x2" / 1000 x 50 x 50mm
- Weight: 2 lbs. / 0.5 kgs



LED PIXEL 4C

121150009

Specification

- 4-Channel Driver/Controller for LED Pixel Tube 360
- Great for the Musician or DJ that wants manual control of his light show
- Linkable via 3-pin XLR cable In/Out to other LED Pixel 4C
- 24 built-in programs
- 4 DMX Channel Modes (5, 7, 14 & 192 Ch.)
- Sound Active
- DMX-512 Protocol
- Electronic Dimming: 0 - 100%
- 4-button LED display
- Built-in, reversible, hanging/truss bracket
- Compatible with ADJ LED RC wireless remote control (sold separately)
- IEC AC Power In/Out on rear to daisy chain power (Power connect up to 8 LED Pixel 4C)
- Low Power Draw: 72W max
- Multi-voltage Operation: AC 100 - 240V, 50/60Hz
- Dimensions (LxWxH): 10.25" x 8" x 3.25" / 259 x 200 x 80mm
- Weight: 5 lbs. / 2 kg.

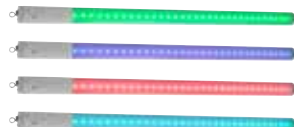

LED PIXEL TUBE 360 SYSTEM

- 4x LED Pixel Tube 360 Color Tubes with attached connectors
- 1x LED Pixel 4C (4-channel Controller/Driver)
- Extension Cables sold separately

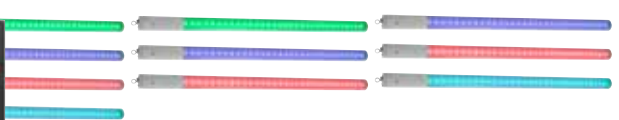

LED PIXEL TUBE 360 SYSTEM IO

- 10x LED Pixel Tube 360 Color Tubes with attached connectors
- 1x Pixel Kling 10C (10-channel Controller/Driver)
- Extension Cables sold separately



WIFLY & BATTERY POWERED FIXTURES



NEW!
7PZ IP



Features:

- IP65
- Outdoor Rated
- LED Par with Zoom
- Wifly EXR Wireless DMX



Technical Information:

Optical:

- Light Source: 7 x 15 Watt Quad (RGBW) LEDs
- LED Life Expectancy: 50,000Hrs
- Beam Angle: 7-45 °

Electrical

- Input Voltage: 100-240V 50Hz/60Hz (Auto Sensing)
- Max Power Draw 128W

Technical Features:

- Compatible with ADJ's Wifly Transceivers
- Strobe-electronic
- 64 built in Color Fade Mode; Auto (Program Run) Mode; Sound Active Mode and DMX-512 Mode
- 4-Button LED Display on Rear Panel
- Electronic Dimming 0-100%
- Flicker Free
- Wifly EXR DMX Range: 2,500 Feet/760m (line of site)
- Wifly On/Off Switch
- Dual bracket yoke allows fixture to be hung or set on the ground

Physical

- Dimensions (LxWxH): 10.5" x 13.75" x 15" / 270 x 350 x 380mm
- Weight: 25lb / 11kg
- Metal Black Housing
- IP 65

Whats Included

- Powercon True1 cable (1M)
- Manual

Connections

- Power Input: Powercon True1 AC
- Power Pass Through: Powercon True1
- Data 3 Seatronic IP Connection

Control

- 4 DMX Channel Modes: 5,7,8 or 12
- 15 Selectable Wifly Address Channels



Compatible with
ADJ RFC
(Sold Separately)
122320026



WiFLY
IP65

WiFLY EXR QA5 IP

1226100292

WiFLY
IP65



Compatible with
ADJ RFC
(Sold Separately)
122320026



WiFLY EXR HEX5 IP

1226100293



Specification

- Light Source: 5x 5-Watt QUAD LEDs (Red, Green, Blue & Amber)
- Smooth RGBA color mixing
- 5 DMX Channel modes: 4, 5, 6, 10 or 11 channel modes
- 5 Operational modes
- IP65 & Outdoor Rated
- Rechargeable Lithium battery powered, with wireless DMX,
- Built-in WiFLY wireless DMX: compatible with ADJ's WiFLY Transceiver (sold separately)
- Extended wireless range - up to 2500 ft/760m
- Battery Life: Up to 20hrs
- Power Draw: 35W total (All LED's @ Full On)
- Multi-voltage operation: AC 100-240V, 50/60Hz
- Dimensions (LxWxH): 10" x 7.5" x 11.75" in. / 254 x 190.5 x 299.5 mm
- Weight: 9.25 lbs. / 4.2 kg

RGBA Color Mixing:



Photometric

R	D25	1596	676	362	170	130	(LUX)
G	D25	2130	885	329	177	117.3	
B	D25	2210	641	277	121.7	78.4	
A	D25	2170	633	399	170	106.9	
RGBA	D25	8200	2480	1078	554	357	

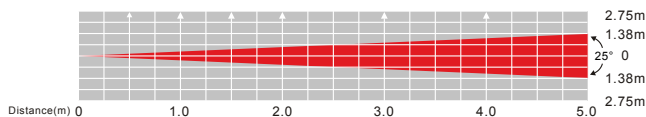

Specification

- LED Source: 5x 10-Watt HEX LEDs (Red, Green, Blue, White & Amber + UV)
- Rechargeable Lithium battery powered, with wireless DMX,
- IP65, & Outdoor Rated
- Built-in WiFLY wireless DMX: compatible with ADJ's WiFLY Transceiver (sold separately)
- Extended wireless range - up to 2500 feet/760m
- 5 DMX Channel modes: 4, 5, 6, 10 or 11 channel modes / Beam angle: 25-degree
- 6 Operational modes: Static Color; RGBAW + UV Dimmer Mode; Color Change; Color Fade; Auto Run (Program Run); and DMX Controlled
- 16 Color Change Modes / 16 Color Fade Modes / 64 built-in Color Macros
- LED pulse and strobe effect / Flicker Free Operation / Electronic Dimming: 0 - 100%
- 4-Pin Power AC IN/OUT outlets on rear to daisy chain power (up to 11 units)
- Power Draw: 50W total (All LED's @ Full On)
- Multi-voltage operation: AC 100-240V, 50/60Hz
- Dimensions (LxWxH): 12.25" x 11" x 7.5" / 310 x 280 x 194mm
- Weight: 12 lbs. / 5.48 kg
- Battery Life: Up to 16hrs

RGBAW Color Mixing + UV:



Photometric

R	D40	971	237	97.8	48.9	32.1	(LUX)
G	D40	951	267	108.5	55.7	37.5	
B	D40	815	217	86	53.1	31.7	
W	D40	1190	302	113.8	67.6	42.3	
A	D40	574	140	50.6	28.9	17.6	
UV	D40	179	47.7	18.3	10.9	6.5	
RGBAW+UV	D40	4240	966	449	241	154.5	

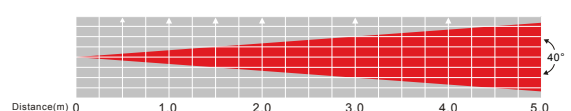



Compatible with
ADJ RFC
(Sold Separately)
1223200026



Compatible with
ADJ RFC
(Sold Separately)
1223200026



WiFLY EXR QAI2BAR IP

1226100294

WiFLY EXR HEX PAR

1226100313



Specification

- Light Source: IP65, Outdoor Rated, par fixture with 12x 5-Watt QUAD LEDs (4-in-1 RGBA- Red, Green, Blue & Amber LEDs, rated at approximately 50,000 hrs)
- 4-button DMX Menu display on rear
- Built-in WiFLY wireless DMX: compatible with ADJ's WiFLY Transceiver (sold separately)
- Extended wireless range - up to 2500 ft/760m
- 3 Zone Control
- Creates no RGBA shadows / 64 built-in Color Macros
- Compatible with ADJ RFC wireless remote control (sold separately)
- Modes: Color Change; Color Jumping; Color Dreaming: Auto (Program Run); Sound Active, WiFLY and DMX Controlled
- DMX Channel modes: 4, 6, 7, 8, 9, 12 and 14
- Beam angle: 25-degree / Linkable via 3-pin IP cable (In/Out)
- Total power consumption: 75W / Multi-voltage operation: AC 100-240V, 50/60Hz
- Dimensions (LxWxH): 40.5" x 5.5" x 6" in. / 1029 x 140 x 152 mm
- Weight: 14 lb. / 6.4 kg.

RGBA Color Mixing:



Specification

- 5x 10-Watt Hex LEDs (6-in-1 RGBWA+UV- Red, Green, Blue, White, Amber, & UV LEDs, rated at approximately 50,000 hrs)
- Rechargeable Lithium battery powered, with wireless DMX
- 4-button DMX menu display on rear panel
- Built-in WiFLY wireless DMX: Up to 2,500 feet (760M) when used with ADJ's WiFLY EXR Battery Transceiver
- 16 Color Change Modes / 16 Color Fade Modes / 63 built-in Color Macros
- Compatible with ADJ RFC wireless remote control (sold separately)
- 5 Operational modes: RGBWA+UV Dimmer Mode; Sound Active mode; Auto Run Mode (16 color change modes, 16 color fade modes, & 1 color/fade combo mode); Static Color mode; and DMX Controlled
- 5 DMX Channel modes: 6, 7, 8, 11 or 12 channel modes
- Beam angle: 40-degree / Linkable via 3-pin IP cable (In/Out)
- Battery Charge Time: 5 Hours (With POWER switch Off)
- Battery Life: Up to 16 hrs
- Power Draw: 58W total (All LED's @ Full On)
- Dimensions (LxWxH): 10.5" x 9.5" x 6.5" / 265 x 240 x 164mm
- Weight: 12 lbs. / 4.42kg.

RGBAW Color Mixing + UV:



Photometric

R	D25	1676	925	557	373	252	
G	D25	1581	806	466	291	197	
B	D25	1880	827	441	293	200	
A	D25	871	544	264	160	101	(LUX)
RGBA	D25	5120	2350	1435	874	496	

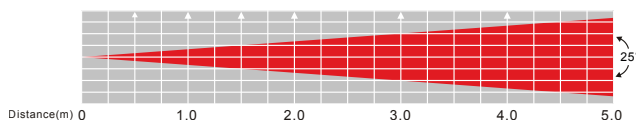

Photometric

R	731	202	97.7	52.6	35.3	
G	717	185	85.1	45.4	30.1	
B	698	156.8	70.8	42.7	27.4	
W	1083	290	123.8	69.3	45.6	(LUX)
A	408	120.9	50.8	27.3	18.1	
UV	225	57.3	21.4	13.5	8.3	
RGBAWUV	3350	866	358	206	140	

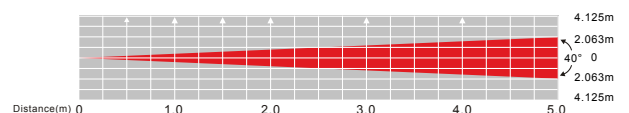



WIFLY BAR QA5

1226200034

12261000257

1226100270



WIFLY PAR QA5 & WIFLY PAR QA5 WH



Specification

- Light Source: 5 X 5W Quad RGBA (Red, Green, Blue, Amber) LED
- Lithium Battery powered Linear Fixture with built in Wireless DMX Control
- Battery Life: Up to 24 hrs; 5 hr Full Charge time
- Pixel Control
- 25° Beam Angle; up to 500ft/150m range for wireless DMX signal control
- DMX Modes : 4,6,7,8,9 or 22 channels: 3 PIN DMX In/Out
- Max Power Draw 58W
- Dimensions (LXWXH): 20" x 6.0" x 6.0" / 502 x 150 x 150mm
- Weight: 9 lbs/ 4 kg

Specification

- Light Source: 5 X 5W Quad RGBA (Red, Green, Blue, Amber) LED
- Lithium Battery powered Par Fixture with built in Wireless DMX Control
- Battery Life: Upt to 24 hrs; 5 Hour Full Charge time
- 25° Beam Angle; up to 500ft/150m range for wireless DMX signal control
- DMX Modes : 1,2,3,4,5,6,7, or 8 channels: 3 PIN DMX In/Out
- Max Power Draw 55W
- Dimensions (LXWXH): 10.5" x 9.5" x 6.5" / 265 x 240 x 164mm
- Weight: 10 lbs/ 4.2 kg



ADJ RFC
(Sold Separately)
1223200026



Compatible With:
WiFLY RCBW8
(Sold Separately)
1226100258



Compatible With:
WiFLY EXR Battery
(Sold Separately)
1226100295



ADJ RFC
(Sold Separately)
1223200026



Compatible With:
WiFLY RCBW8
(Sold Separately)
1226100258



Compatible With:
WiFLY EXR Battery
(Sold Separately)
1226100295

RGBA Color Mixing:



RGBA Color Mixing:



Photometric

	R	943	335	132	60	45	
	G	1022	369	149	80	41	
	B	1012	292	135	62	43	
	W	898	290	127	69	42	
Beam Angle 25°	RGBW	3440	1100	552	300	185	(LUX)

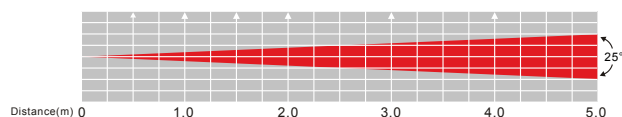

Photometric

	R	2750	704	307	150	95	
	G	2260	549	247	142	84	
	B	2740	775	364	188	108	
	W	2660	769	296	168	82	
Beam Angle 25°	RGBW	9650	2730	1184	611	384	(LUX)

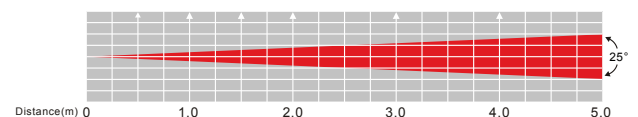



Compatible with:
DOTZ PAR RF remote (Sold Separately)
1223200035



ADJ RFC
(Sold Separately)
1223200026

WiFLY EXR DOTZ PAR

1223200040

WiFLY PAR QA5 IP

1226100273



Specification

- Light Source: 1 x 36W TRI COB LED (rated at approximately 50,000 hrs)
- Rechargeable Lithium battery powered, with wireless DMX
- Battery Charge Time: 4 Hours
- Battery Life: 8 Hours Full On (With Full Charge)
- 5 DMX Channel modes: 3/4/5/5/9 channel modes (Two 5 DMX Channel Modes)
- 7 Operational modes: Static Color; Sound Active Mode; RGB Dimmer Mode; 3 ColorChange; 7 Color Change Mode; Color Fade; and DMX Controlled
- 32 built-in Color Macros
- Beam Angle: 20 Degrees (w/ Lens) 66 Degrees (w/o Lens)
- Power Draw: 38W total (Full On)
- AC IN/OUT outlets on rear to daisy chain power (up to 10 units @ 110V and 18 units @ 240V)
- Multi-voltage operation: AC 100-240V, 50/60Hz
- Dimensions (LxWxH): 8.25" x 7.75" x 9.75" / 210 x 200 x 250mm
- Weight: 12 lbs. / 5.5 kg.



R	2470	815	406	241	147	
G	3260	1054	540	316	198	(LUX)
B	5060	1644	839	486	324	
RGB	11950	3280	1545	940	611	

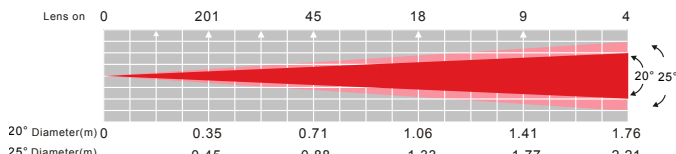

R	128	34	15	8	5	
G	239	68	29	16	10	(LUX)
B	325	81	38	22	14	
RGB	646	175	81	48	31	

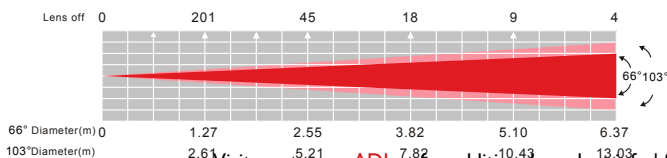

Specification

- Light Source: 5x 5-Watt QUAD LEDs
- IP65, Outdoor Rated, par fixture with five Quad RGBA LEDs (4-in-1 Red, Green, Blue & Amber LEDs)
- Creates no RGBA shadows
- 8 Operational modes: Manual Color; Color Change; Color Jumping; Color Dreaming: Auto (Program Run); Sound Active, WIFLY and DMX Controlled
- 64 built-in Color Macros
- Beam angle: 40-degree
- 4-Pin Power AC IN/OUT outlets on rear to daisy chain power (up to 15 units)
- Power Draw: 35W total (All LED's @ Full On)
- Multi-voltage operation: AC 100-240V, 50/60Hz
- Dimensions (LxWxH): 10" x 7.5" x 12" / 250 x 190 x 300mm
- Weight: 10 lbs. / 4.2 kg.



Photometric

R	1071	273	114.7	62.3	40.8	
G	1245	304	132.4	68.9	46.5	(LUX)
B	1166	291	121	67.4	44.5	
A	556	140	58	32	21	
RGBA	3520	990	389	228	136.1	

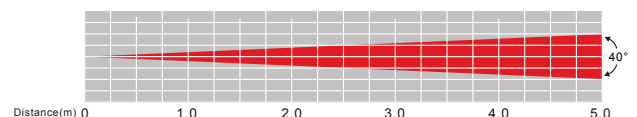

WIFLY D6 BRANCH

1226100255



Specification

- 6-Way DMX Splitter/Amplifier compatible with ADJ's WiFLY Wireless DMX built-in
- 1x DMX In, 6x DMX Out (all 3-pin XLR's)
- Link with other WiFLY D6 Branch Splitters
- 16x Operating Frequencies
- Input & outputs are electrically and optically isolated from each other
- Includes 2x Velcro straps to securely attach to truss
- Clamp mount bracket included
- On/Off power switch
- Multi-voltage operation: AC 100-240V, 50/60Hz (IEC Socket)
- Dimensions (LxWxH): 6" x 4.75" x 4.75" / 150 x 120 x 120mm
- Weight: 4 lbs/ 1.45 kg.

WIFLY EXR BATTERY

1226100295



Specification

- Battery powered wireless DMX transceiver (transmitter/receiver in one)
- Battery Life: Up to 20 hours
- Battery life and WIFLY wireless signal strength indicators on side panel
- Magnetic bottom plate for temporary, quick and easy mounting to metal fixtures or objects
- Compatible with all ADJ WiFLY products
- Up to 2500 wireless feet (open line of sight)
- One transmitter can send to many receivers using the same radio channel
- Receivers automatically listen for transmitters (no pairing required)
- Supports up to 16 DMX-512 universes
- Dip Switches to select from 16 different radio channels (one DMX universe per channel)
- 3-pin & 5-pin DMX In/Out
- Wireless Frequency: 2.4 GHz DSSS
- Power Supply: DC 9-12V (AC or DC powered)
- Dimensions (LxWxH): 6" x 5.5" x 2.5" / 148 x 135 x 62mm
- Weight: 2 lbs. / 0.75 kg.





WiFLY NE1

1226100296

WiFLY RGBW8C

1226100258



Specification

- DMX Controller with ADJ's WIFLY Transceiver Wireless DMX on-board.
- Control up to 12 individual fixtures
- Designed for Inno Series products but can control most DMX products that consist of 34 DMX channels or less
- Built-in effects generator for LED's and Moving Lights
- 12 Memories via 2 banks
- 4 Rotary Encoders for Channel & Function Control
- Master Dimmer Fader Control
- Strobe Rate Fader Control
- 6 Mode buttons (Fixture, Color, Gobo, Effect, Show, & Pause)
- 12 Multi-function buttons
- Blackout button
- Universal USB Port (USB Stick Included)
- DMX output connector: 3-pin XLR
- Power In: 9-12V DC min 300mA UL approved power supply (Included)
- Power consumption: 3.6 Watts
- Size: 12.8" x 7.25" x 2.75" (325 x 185 x 68.7mm)
- Weight: 4.4 lbs. (2 kgs.)

Specification

- Compact DMX-512 controller for RGB, RGBW and RGBA LED fixtures.
- Up to 8 channels can individually be controlled per fixture button.
- Built-In Wifly Transceiver, which will allow you control all Wifly compatible light fixtures wirelessly. (Can also be hard wired via 3 pin DMX cables)
- Built in RGB Fade, Auto program, Color Macro, Chase Programs
- 16x Operating Frequencies
- 4 Faders for manual RGBW or RGBA 4 channel control
- 3 user programmable color preset, direct access buttons
- 9 Color preset/Chase program direct access buttons
- Sound active mode via internal microphone
- Power consumption: 3.6 Watts
- Size: 13" x 5.75" x 2" (327 x 140 x 48mm)
- Weight: 3 lbs. (1.3 kgs.)





WASH LIGHTING



-  ADJ LED RC4
(Sold Separately)
-  UC-IR
(Sold Separately)
1321000074
-  AIRSTREAM IR
1226100319



WiFLY CHAMELEON

1226100320

-  Compatible with:
ADJ LED RC2
(Sold Separately)
-  UC-IR
(Sold Separately)
1321000074
-  AIRSTREAM IR
1226100319

CHAMELEON QBAR PRO

1226100325



Specification

- 3 x 15W RGBA+UV (5-in-1) LEDs
- Rechargeable Lithium battery powered with built-in wireless DMX
- 63 Static Colors
- 6 Operating Modes: RGBA+UV Dimmer Mode, Built-In Program Mode (22 Programs) Auto
- Run Mode, Static Color Mode, Sound Active Mode, & DMX Control
- LED pulse & strobe effect / Electronic Dimming: 0 - 100%
- Tilt: 270-degree / 5-40 degree beam angle
- DMX512 Protocol 3-pin XLR In/Out
- IEC in/out to Daisy Chain Power (Connect up to 14 fixtures max.)
- Power Consumption: 45W
- Rechargeable Lithium battery life: 4.5 Hour Battery Life (Full On in Normal Mode)
- 6 Hour Battery Life (Energy Saving Mode with Full Charge)
- Battery Charge Time: 3 Hours (With LOAD switch Off)
- Multi-voltage Operation: 100-240V, 50Hz/60Hz
- Dimensions (LxWxH): 230x220x168mm / 9" x 8.75" x 6.5"
- Weight: 9 kg. / 4.15 lbs.

Specification

- Built-in WiFLY Extended Range wireless DMX (up to 2,500 ft/762m)
- Adjustable head to manual change beam direction
- Individual Pixel Control
- 2 x 8 Character LCD Display
- 19 Built-In Programs
- 63 Color Macros
- LED pulse & strobe effect
- Electronic Dimming: 0 - 100%
- Compatible with all ADJ WiFLY fixtures and controllers plus the ADJ LED RC2, UC IR wireless remotes (both remotes sold separately), and Airstream IR
- 7 DMX channel modes 4/5/7/9/10/12/14
- 6 Operating Modes: RGBA Dimmer Mode, Built-In Program Mode (19 Programs), Auto Run Mode, Static Color Mode, Sound Active Mode, & DMX Control
- 15 degree beam angle
- DMX-512 Protocol 3-pin XLR In/Out
- IEC in/out to Daisy Chain Power (Connect up to 6 fixtures max.)
- Power Consumption: 100W
- Multi-voltage Operation: 100-240V, 50Hz/60Hz
- 3 x 30W RGBA (4-in-1) LEDs
- Dimensions (LxWxH): 270 x 100 x 260mm / 10.5" x 4" x 10.25"
- Weight: 8 lbs. / 3.7 kg.

Photometric

	0.5m	1m	2m	3m	4m	5m	Distance (m)
5°	0.105	0.21	0.42	0.63	1.05	1.05	
R	2010	693	177.9	72	48.5	28.7	(LUX)
G	1890	657	173.4	58.8	41.3	22.9	
B	2810	890	194.3	89.7	50.1	29.2	
A	944	339	74.3	32.8	16.3	8.4	
UV	820	303	68.7	24.7	13.3	8.4	
RGBA+UV	9500	1900	427	192	109.7	67.2	

	0.5m	1m	2m	3m	4m	5m	Distance (m)
40°	0.35	0.7	1.4	2.1	2.8	3.5	
R	1197	318	80.6	59.3	22.1	13.1	(LUX)
G	1174	224	55.6	25.7	14.1	8.9	
B	1190	297	80.8	39.7	22.6	14.1	
A	439	153.6	33.6	14.8	8.6	5.8	
UV	291	72.9	20.5	8.6	4.7	2.9	
RGBA+UV	3360	791	221	89.7	51.2	33.7	

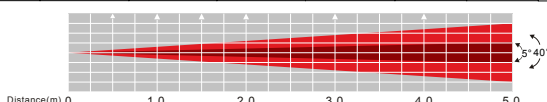

Photometric

	R	D15	580	89.5	40.1	17.5	11.7	
G	D15	299	57.1	24.8	13.2	8.7		(LUX)
B	D15	394	105.4	47.1	18.1	11.6		
W	D15	470	114.2	55.7	29.4	19.2		
A	D15	120.8	28.2	11.8	6.8	4.1		
UV	D15	62.6	21.9	10.4	5.3	3		
RGBA+UV	D15	1163	196	97.3	53.6	33.4		

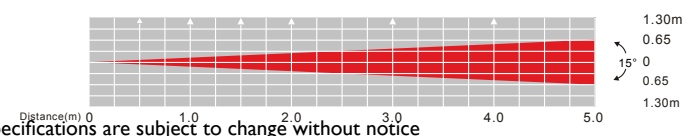



DOTZ MATRIX

1215200023



Specification

- Light Source: 16 X 30W COB Tri RGB LEDs in a 4x4 Matrix Panel
- Operational modes: DMX, Manual RGB Mode, Static Color & Sound Active
- DMX channels: 3,6,7, 48 or 52; 3 & 5 Pin In/Out
- Electronic Dimming: 0 - 100%
- Beam Angle: 60 degrees for wide coverage
- Built-In preset colors and programs
- 5 selectable Dim Curves (Standard, Stage, TV, Architectural & Theatre)
- Powercon AC IN/OUT; Daisy Chain up to 5 units @120V, 9 units @ 220V
- Power Draw: 430W Max; 3.91 Amps @120V, 1.95 Amps@220V
- Multi-voltage Operation: 100-240V, 50Hz/60Hz (auto sensing)
- Dimensions (LxWxH: 13.75" x 6.75" x 14.75" / 345 x 170 x 370mm
- Weight: 18 lbs. / 7.8 kg.

RGB Color Mixing:



Photometric

Beam Angle 60°	R	2130	681	302	197	136	(LUX)
	G	3050	793	398	246	173	
	B	4730	1405	716	368	224	
	RGB	10140	1405	1360	730	476	
	Spot Diameter		2.65	3.75	4.90	6.05	

Field Angle 60°	R	974	270	114	66	45	(LUX)
	G	1444	405	185	109	71	
	B	2010	574	270	154	101	
	RGB	3370	1011	475	265	171	
	Spot Diameter		3.65	5.33	7.00	8.70	

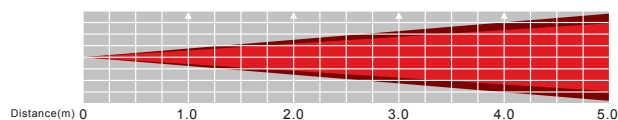



1223200039

1223200042

COB CANNON WASH/PEARL



COB CANNON DW

1223200045



Specification

- Light Source: 1x 150-Watt COB Quad LED (RGBA: 4-IN-1, rated at approximately 50,000 hrs)
- Use as Wash/par or Pixel Mapped for a stunning visual effect
- 7 DMX channel modes (3, 4, 5, 6, 7, 9, 10 ch.)
- Built-in Color Macros
- 5 selectable Dim Curves (Standard, Stage, TV, Architectural & Theatre)
- 80-degree beam angle
- Includes lens kit to change to 40-degrees or 50-degrees beam angle
- Compatible with wireless remote control ADJ RFC (sold separately)
- 3-pin XLR chassis mount connectors for DMX linking
- 3 & 5-pin XLR DMX IN/OUT
- Powercon In/Out
- Auto sensing power supply: AC 100V/60Hz - 240V/50Hz
- Dimensions (LxWxH): 16.5"x9.75"x7.75" / 415x245x192mm
- Weight: 9 lbs. / 4.1 kg.



ADJ RFC
(Sold Separately)
1223200026

Specification

- With one WW/CW COB LED
- COB Technology (Chip On Board) produces powerful, smooth Dynamic White mixing
- 150w ww/cw COB
- Built-In preset colors and programs
- Flicker Free operation (No flickering on camera)
- LED pulse and strobe effect
- Electronic Dimming: 0 - 100%
- Selectable Dim Curves (Standard, Stage, TV, Architectural & Theatre)
- Beam angle: 40-degrees & 50-degrees with supplied lens kit
- 3-pin XLR chassis mount connectors for DMX linking
- Power Con in/out to daisy chain power
- 4-button digital DMX display on rear panel
- Compatible with wireless remote control (sold separately)
- Single yoke allows fixture to be mounted
- Approximately 50,000 hrs
- Auto sensing power supply: AC 100V/60Hz - 240V/50Hz

Photometric

Beam Angle 40°	0.4375	0.875	1.75	2.625	3.50	4.375	
R	10650	2530	611	289	168	111	(LUX)
G	8490	1869	511	226	130	91	
B	8540	1950	545	242	135	95	
A	3110	997	253	113.8	61.1	39.1	
RGBA	25900	7320	1970	810	474	297	

Beam Angle 50°	0.53	1.06	2.12	3.18	4.24	5.30	
R	5780	1475	393	170.8	98.5	65.4	(LUX)
G	4760	1360	335	154.4	90.5	58.8	
B	4800	1454	372	172.8	96.4	64.9	
A	2480	892	191	85.4	48.8	31.4	
RGBA	24300	5240	1472	681	373	240	

Beam Angle 80°	1.01	2.02	4.04	6.06	8.08	10.1	
R	3900	975	247	112.5	66.3	44.7	(LUX)
G	3650	853	219	103.8	60.5	39.1	
B	3660	926	246	110.4	65.9	42.5	
A	2350	689	159.3	67.9	37.2	25.1	
RGBA	12360	3590	996	549	238	159.9	

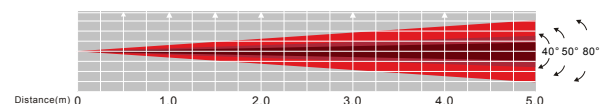



Compatible with: Dotz PAR RF remote (Sold Separately) 1223200035



DOTZ PAR

1223200032



Compatible with: Dotz PAR RF remote (Sold Separately) 1223200035



DOTZ PAR 100

1223200038

Standard 60° or 25° kit included to adjust beam angle

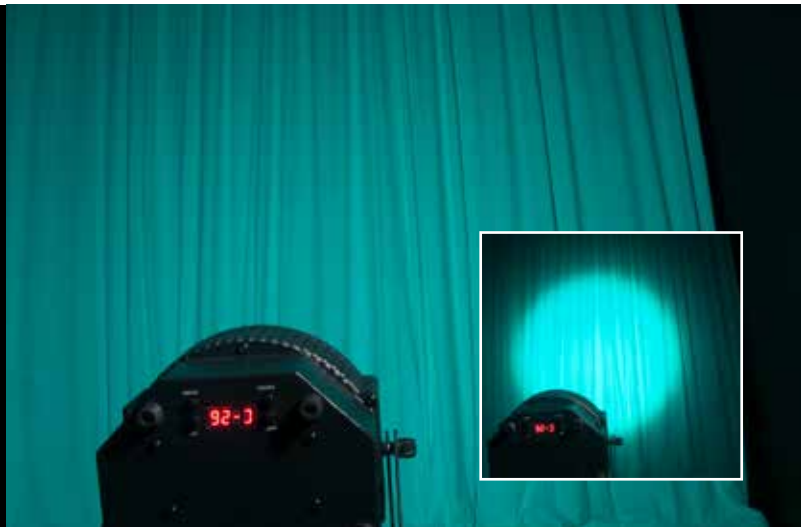
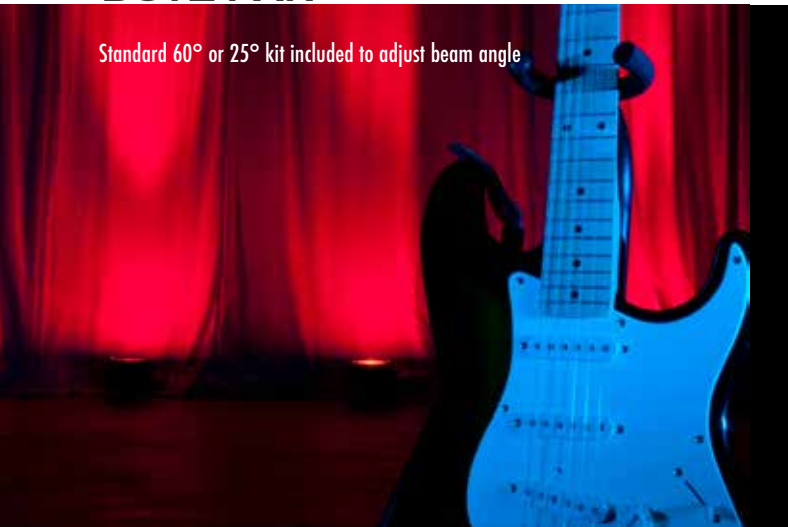

Specification

- Light Source: 1x 36-Watt COB TRI LED (RGB: 3-IN-1, rated at approximately 50,000 hrs)
- 5x Operational modes: Auto, Sound Active, Color Macro, Dimmer, and DMX Controlled Mode
- IEC AC IN/OUT to daisy chain power (up to 13 Dotz Par's @ 110V and 28 Dotz Par's @ 230V)
- Power Draw: 36W total (All LEDs @ Full On)
- Auto sensing power supply: AC 100V/60Hz - 240V/50Hz
- Dimensions (LxWxH): 209 x 114 x 222mm (with bracket)
- Weight: 5 lbs. / 2 kgs.

Photometric: Lens On

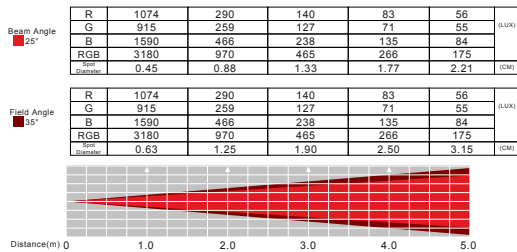

Photometric: Lens Off

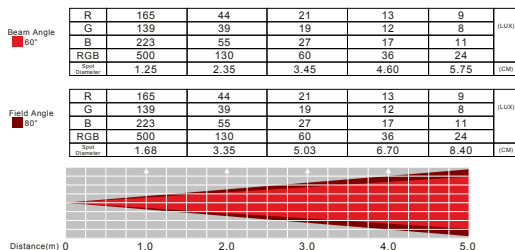

Specification

- Light Source: 1x 100W COB TRI LED (RGB: 3-IN-1, rated at approximately 50,000 hrs)
- COB Technology (Chip On Board) produces powerful, smooth RGB color mixing with rich palettes of color
- 5x Operational modes: Auto Run, Sound Active, Color Macro, Dimmer, and DMX
- 4 DMX channel modes: 3, 4, 5 or 9 channel
- Built-In preset colors and programs / 35 built-in Color Macros
- 5 selectable Dim Curves (Standard, Stage, TV, Architectural & Theatre)
- Beam angle: 80-degrees (25-degrees with supplied lens kit)
- 3-pin XLR chassis mount connectors for DMX linking
- IEC AC IN/OUT to daisy chain power (up to Dotz Par's @ 110V and Dotz Par's @ 230V)
- Power Draw: 100W total (All LEDs @ Full On)
- Dimensions (LxWxH): 255 x 130 x 284mm (with bracket)
- Weight: 3.1 kgs.

Photometric: Lens On

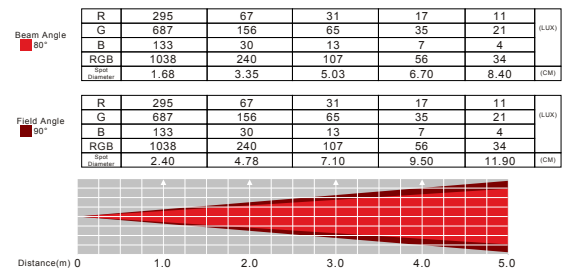

Photometric: Lens Off

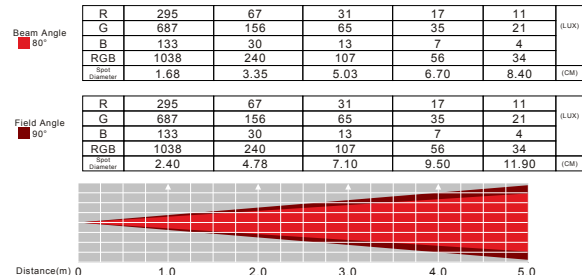



PAR Z4

1226200050



ADJ RFC
(Sold Separately)
1223200026



NEW!
18P HEX

12261000333



Specification

- High output mini par with manual zoom
- 4 x 15W Quad RGBW LED source
- 5 Operational modes: DMX Control, Sound Active Mode, Show Mode, Static Color Mode, Color Fade Mode.
- 4 DMX Channel Modes: 4/6/8/9
- 63 Color Macros
- Stand Alone Set Up or Master-Slave Configuration
- Beam Angle: 10 - 60-degrees
- Full ZOOM 10-60 Degrees
- 5 selectable Dim Curves (Standard, Stage, TV, Architectural & Theatre)
- Shutter: Pulse effect; random strobe slow to fast
- Dimming: 0% - 100%
- Display Inversion Mode
- Linkable: DMX via 3-pin XLR cable
- Compatible with ADJ UC IR wireless remote control (ADJ UC IR sold separately) and iOS App Airstream IR (IR dongle included)
- Power consumption: 52W (Full-On)
- IEC AC input and output on rear to daisy chain power (Up to 13 fixture's @ 120V & 24 fixture's @ 230V)
- Multi-voltage Operation: AC 100 - 240V, 50/60Hz
- LED Source: 4 x 15W 4-in-1 RGBW LED source (Rated at approximately 50,000 hrs)
- Dimensions (LxWxH): 263 x 185 x 221mm (With Bracket)
- Dimensions (LxWxH): 263 x 185 x 118mm (Without Bracket)
- Weight: 2.5 kgs

Specification

- Light Source: 18 x 12 - Watt Hex (RGBAW + UV) LEDs
- LED Life Expectancy: 50,000Hrs
- Beam Angle: 30-Degree
- 63 Built in Color Macros
- 50Operational Modes: Manual Color; Color Fade; Auto Program; Sound Active, and DMX Modes
- 4-button Digital Display for easy navigation
- Electronic Dimming
- Flicker Free
- Gel Frame Included
- Power Input: powerCON IN
- Power Pass through: powerCON Out (Daisy Chain up to 10 Units @ 120V, 12 Units @ 230V)
- Control: 3-Pin DMX
- 4 DMX Channel Modes: 6, 7, 8 and 12
- Compatible with Dotz Par RF (Sold Separately)
- On Board Control
- Input Voltage: 100-240V 50Hz/60Hz (Auto Sensing)
- Dimensions (LxWxH): 12" x 6.75" x 13.5" / 300 x 170 x 340mm
- Weight: 12lbs / 5.4kg
- Metal Black Housing
- ETL
- IP 30, Dry Area, No liquids
- PowerCON Cable (1M)



RGBW Color Mixing:





12P HEX/12P HEX PEARL

5P HEX/5P HEX PEARL



Specification

- Light Source: 12x 12-Watt RGBAW + UV LEDs, (Rated at approximately 50,000 hrs.)
- 4 DMX Modes: 6, 7, 8, & 12 channel
- 5 Operational modes: Static Color Mode, RGBAW & UV Dimmer Mode, Program Mode, Sound Active Mode and DMX Controlled
- 7 Built-In Programs / 63 built-in Color Macros / Flicker Free operation
- 5 selectable Dimmer Curves (Standard, Stage, TV, Architectural & Theatre)
- Beam angle: 30-degree
- Compatible with Dotz Par RF wireless remote control (sold separately)
- Power link via IEC power cables. (6x 12P Hex's Max @ 110V, 13x 12P Hex's Max @ 240V)
- Power Draw: 150W total (All LED's @ Full On)
- Multi-voltage operation: AC 110-250V, 50/60Hz (IEC power In/Out)
- Dimensions (LxWxH): 11.75" x 10" x 5.5" / 298 x 249 x 136mm
- Weight: 9 lbs. / 3.9 kgs

Specification

- Light Source: 5 x 10-Watt RGBAW + UV LEDs, (Rated at approximately 50,000 hrs.)
- Smooth RGBAW + UV color mixing
- 4 DMX Modes: 6, 7, 8, & 12 channel
- 5 Operational modes: Static Color Mode, RGBAW & UV Dimmer Mode, Program Mode, Sound Active Mode and DMX Controlled
- 7 Built-In Programs / 63 built-in Color Macros
- 5 selectable Dim Curves (Standard, Stage, TV, Architectural & Theatre)
- Compatible with Dotz Par RF wireless remote control (sold separately)
- Data linkable via 3-pin XLR cables / Power linkable via IEC power cables
- Power Draw: 60W total (All LED's @ Full On)
- Multi-voltage operation: AC 100-240V, 50/60Hz (IEC power In/Out)
- Dimensions (LxWxH): 8.25" x 4" x 8.75" / 210 x 100 x 220mm
- Weight: 5 lbs. / 2 kgs

RGBAW Color Mixing + UV:



RGBAW Color Mixing + UV:



Photometric

	R	1024	312	150	85	55	
	G	2180	641	305	172	112	
	B	2990	305	376	217	135	
	W	3620	810	428	247	162	
	A	1195	961	179	104	70	
	UV	442	384	83	36	26	
Beam Angle 30°	RGBAWUV	10890	2770	1330	733	455	(LUX)

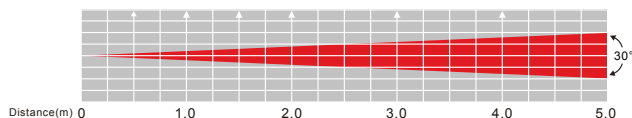

Photometric

	R	562	152	70	40	27	
	G	1121	300	136	76	49	
	B	1030	283	130	75	48	
	W	1544	410	187	101	66	
	A	387	100	45	28	20	
	UV	313	81	37	21	14	
Beam Angle 30°	RGBAWUV	4420	1220	561	318	210	(LUX)

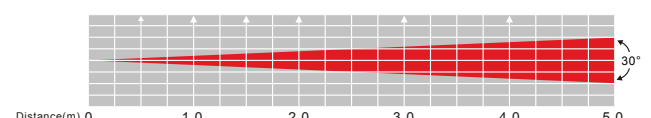

ADJ RFC
(Sold Separately)
1223200026



ULTRA HEX PAR3

1226100274

HEXCON

1321000077



Specification

- Light Source: 3x 10-Watt RGBAW + UV LEDs, (Rated at approximately 50,000 hrs.)
- Ultra bright, flat Par 38 wash fixture with 3x Red, Green, Blue, Amber, White & UV LED pixels
- 5 DMX Modes: 6, 7, 8, 11 & 12 channel
- 5 Operational modes: Static Color, Dimmer, Auto Run, Sound Active and DMX Controlled
- Beam angle: 40-degree
- Power Draw: 26W total (All LED's @ Full On)
- Multi-voltage operation: AC 100-240V, 50/60Hz (IEC power In/Out)
- Dimensions (LxWxH): 9" x 8.5" x 4.75" / 224 x 213 x 120mm
- Weight: 5 lbs. / 2.02 kgs

Specification

- Compact DMX controller for ADJ HEX series products
- Control up to 6 individual, RGBWA+UV LED fixtures or fixture groups
- 6 user programmable presets, direct access buttons
- 24 Color preset direct access buttons
- 6 multi-function faders
- Color Macro playback mode
- Manual RGBWA+UV intensity control mode
- Color Fade Mode, Color Chase Mode, Auto Run, Sound Active, and Strobe functions.
- On the fly Speed & Fade control of all chase programs
- Sound active mode via internal microphone
- Adjustable microphone sensitivity
- Variable strobe
- Blackout button
- DMX output connector: 3-pin XLR
- USB phone port (Charges most mobile phones)
- Power In: 12VDC 500mA UL approved power supply (Included)
- Power consumption: 3.6 Watts
- Dimensions: 361 x 185 x 65mm
- Weight: 1.74kg

RGBAW Color Mixing + UV:



Photometric

	R	460	125	56	31	20	
	G	451	128	55	31	21	
	B	359	106	47	27	17	
	W	624	174	78	41	26	(LUX)
	A	261	70	29	17	9	
	UV	87	21	10.1	5.7	3.8	
	RGBAWUV	1947	561	251	140	91	

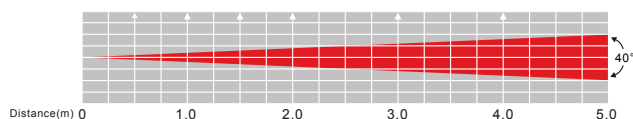

NEW!



MEGA QA GO

1226100329



MEGA QPLUS GO

1226100328



Specification

- Light Source 5x4 Watt Quad (RGBA) LEDs
- LED Life Expectancy, 50,000Hrs
- Compatible with ADJ UC IR Wireless Remote Control
- 64 Built In Static Colors (Stand Alone)
- 5 Operational Modes: Manual Color Mode; 16 Color Fade Modes; 16 Auto (Program Run) Modes; Sound Active Mode and DMX-512 Mode
- 4-button Digital Display for Easy Navigation
- Electronic Dimming 0-100%
- Flicker Free
- Separate Battery & Load On/Off Switch
- Includes a scissor Yoke to be hung, or set on the ground
- Power Pass through: IEC (Link up to 20 Units @ 110V)
- 8 DMX Channel Modes: 1, 2, 3, 4, 5, 6, 7, 8
- Compatible with ADJ UC IR (sold separately) & AirStream IR APP (iOS Only)
- Input Voltage: 100-240V 50Hz/60Hz (Auto Sensing)
- Power draw 120V 60Hz: 28W, 0.23 Amps
- Power draw 220V 50Hz: 55W, 0.25 Amps
- Rechargeable Battery Life: 6 hours full on (with a full charge) 9 hour charge time
- Rechargeable Battery Life Expectancy: (Average) 500 charges
- Dimensions (LxWxH): 5.5" x 9" x 10" / 253 x 227 x 140mm
- Weight: 4lbs/1.9kg.

Photometric

R	1201	300	126.2	67.5	43.5
G	1038	244	104.7	61.2	37.5
B	1124	286	124.4	66.7	42.9
A	607	176.8	71.4	36.5	23
RGBA	2830	622	305	182.3	109.4

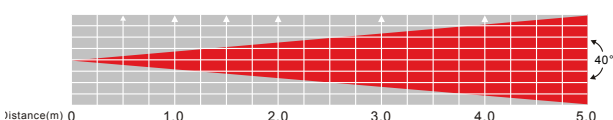

Specifications

- Ultra bright slim flat black Par with 5 x 4-Watt, 4-IN-1 Quad LEDs
- Smooth RGB + UV Color Mixing (fast or slow color change operation)
- Unique "sit-flat" design: Power & DMX Ins/Outs intelligently designed so the unit can be set flat on the ground or set inside truss
- 8 DMX Channel modes: 1, 2, 3, 4, 5, 6, 7 or 8 channel modes
- 5 Operational modes: Auto Run Mode (16 Color Change Mode, 16 Color Fade Modes, & 1 Combined Mode), Sound Active Mode (16 Modes), RGB + UV Dimmer Mode, Static Color Mode (64 Colors), and DMX Controlled
- Digital DMX Display with 4-button menu for easy navigation
- Stand Alone or Master/Slave Configuration
- Beam Angle: 40 degrees
- 64 built-in Color Macros
- DMX-512 protocol
- Color strobe effect
- Electronic Dimming: 0-100%
- Flicker Free
- Power Draw: 28W Max
- IEC AC input and out put on the side of the fixture to daisy chain the power cords (link up to 20 fixtures)
- Compatible with UC IR wireless remote (sold separately) & Airstream IR app
- Rechargeable Lithium battery life: 4 hours full on (with a full charge); 5.5 Hours in Energy Saving Mode (With Full Charge, 4 hours charge time (With LOAD Off), up to 22 hours depending on chosen color
- Multi-voltage operation: AC 100V-240V 50/60Hz
- Dimensions (LxWxH): 253 x 227 x 140mm
- Weight: 1.9 kg.

R	1316	403	2184.1	98.6	66.6
G	1234	345	151.1	85.5	54.4
B	1265	392	165.9	91.8	60.2
UV	298	87.4	39.5	22.2	15.4
RGB+UV	3460	921	442	253	149.5

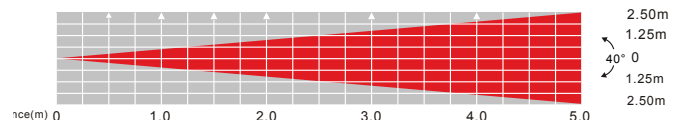

Visit us at www.ADJ.eu for additional product info | Specifications are subject to change without notice



Compatible with:
LED RC2
(Sold Separately)
1226200027



FLAT PAR QAI2XS

1226100300



Compatible with:
LED RC2
(Sold Separately)
1226200027



FLAT PAR QWHI2XS

1226100301



Specifications

- Light Source: Ultra bright slim fixture with 12x 5-Watt QUAD LEDs (4-in-1 RGBA- Red, Green, Blue & Amber)
- Snoot Frame included to help limit unwanted light exposure
- 8 DMX Channel modes: 1, 2, 3, 4, 5, 6, 7 or 8 channel modes
- 6 Operational modes: Manual Color Mode; Color Change Mode; Color Fade Mode; Auto (Program Run) Mode; Sound Active Mode and DMX-512 Mode
- Smooth RGBA color mixing (fast or slow color change operation)/ 15 built-in Color Macros
- Beam Angle: 25 degree / Power Draw: 80W max
- IEC AC IN/OUT outlets on rear to daisy chain power (up to 7 units)
- Multi-voltage operation: AC 100-240V, 50/60Hz (IEC power In/Out)
- Dimensions (LxWxH): 13"x11"x4.5" / 328x280x115mm
- Weight: 7 lbs. / 3.2 kg.

RGBA Color Mixing:



Photometric

R	D25	5130	1449	685	396	260	(LUX)
G	D25	4760	1369	628	355	227	
B	D25	5780	1681	778	448	292	
A	D25	2308	693	326	182	117	
RGBA	D25	14480	4656	2104	1178	753	

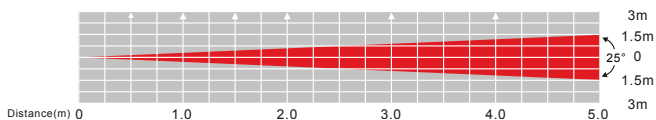

Specifications

- Light Source: Ultra bright slim fixture with 12x 5-Watt QUAD LEDs (4-in-1 RGBW- Red, Green, Blue & White)
- Snoot Frame included to help limit unwanted light exposure
- 8 DMX Channel modes: 1, 2, 3, 4, 5, 6, 7 or 8 channel modes
- 6 Operational modes: Manual Color Mode; Color Change Mode; Color Fade Mode; Auto (Program Run) Mode; Sound Active Mode and DMX-512 Mode
- Smooth RGBW color mixing (fast or slow color change operation)/ 15 built-in Color Macros
- Beam Angle: 25 degree / Power Draw: 80W max
- IEC AC IN/OUT outlets on rear to daisy chain power (up to 7 units)
- Multi-voltage operation: AC 100-240V, 50/60Hz (IEC power In/Out)
- Dimensions (LxWxH): 13"x11"x4.5" / 328x280x115mm
- Weight: 7 lbs. / 3.2 kg.

RGBW Color Mixing:



Photometric

R	D25	5130	1449	685	396	260	(LUX)
G	D25	4760	1369	628	355	227	
B	D25	5780	1681	778	448	292	
W	D25	6410	1925	905	506	324	
RGBW	D25	18100	5820	2630	1473	941	

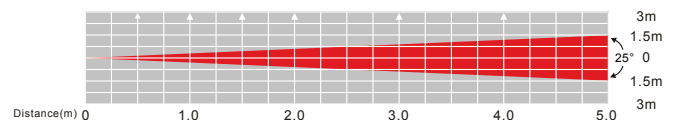



Compatible with:
LED RC2
(Sold Separately)
1226200027



FLAT PAR QA5XS

1226100299



Compatible with:
LED RC2
(Sold Separately)
1226200027



FLAT PAR QWH5XS

1226100302



Specification

- Light Source: Ultra bright slim fixture with 5x 5-Watt QUAD LEDs (4-in-1 RGBA- Red, Green, Blue & Amber)
- Snoot Frame included to help limit unwanted light exposure
- Smooth RGBA color mixing (fast or slow color change operation)
- 8 DMX Channel modes: 1, 2, 3, 4, 5, 6, 7 or 8 channel modes
- 6 Operational modes: Manual Color Mode; Color Change Mode; Color Fade Mode; Auto (Program Run) Mode; Sound Active Mode and DMX-512 Mode
- 15 built-in Color Macros
- Beam Angle: 25 degrees / Power Draw: 34W Max
- IEC AC IN/OUT outlets on rear to daisy chain power (up to 18 units)
- Multi-voltage operation: AC 100-240V, 50/60Hz (IEC power In/Out)
- Dimensions (LxWxH): 10.75"x9"x4.5" / 272x230x115mm
- Weight: 6 lbs. / 2.5 kg.

RGBA Color Mixing:



Photometric

R	D25	2750	704	307	150	95	(LUX)
G	D25	2260	549	247	142	84	
B	D25	2740	775	364	188	108	
A	D25	958	277	106	60	29	
RGBA	D25	7720	2184	947	489	307	

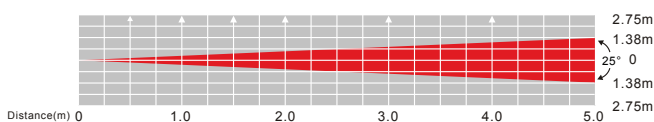

Specification

- Light Source: Ultra bright slim fixture with 5x 5-Watt QUAD LEDs (4-in-1 RGBW- Red, Green, Blue & White)
- Snoot Frame included to help limit unwanted light exposure
- Smooth RGBW color mixing (fast or slow color change operation)
- 8 DMX Channel modes: 1, 2, 3, 4, 5, 6, 7 or 8 channel modes
- 6 Operational modes: Manual Color Mode; Color Change Mode; Color Fade Mode; Auto (Program Run) Mode; Sound Active Mode and DMX-512 Mode
- 15 built-in Color Macros
- Beam Angle: 25 degrees / Power Draw: 34W Max
- IEC AC IN/OUT outlets on rear to daisy chain power (up to 18 units)
- Multi-voltage operation: AC 100-240V, 50/60Hz (IEC power In/Out)
- Dimensions (LxWxH): 10.75"x9"x4.5" / 272x230x115mm
- Weight: 6 lbs. / 2.5 kg.

RGBW Color Mixing:



Photometric

R	D25	2750	704	307	150	95	(LUX)
G	D25	2260	549	247	142	84	
B	D25	2740	775	364	188	108	
W	D25	2660	769	296	168	82	
RGBW	D25	9650	2730	1184	611	384	

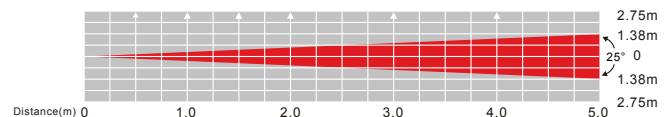



Compatible with:
ADJ LED RC
(Sold Separately)
122620027



FLAT PAR TRII8XS

1226100310



Compatible with:
ADJ LED RC
(Sold Separately)
122620027



FLAT PAR TRI7XS

1226100303



Specification

- Light Source: Ultra bright slim Par Can with 18x 3-Watt TRI LEDs (3-in-1 RGB)
- Smooth RGB color mixing (fast or slow color change operation)
- Snoot Frame included to help limit unwanted light exposure
- 7 DMX Channel modes: 1, 2, 3, 4, 5, 6 or 7 channel modes
- 6 Operational modes: Manual Color Mode; Color Change Mode; Color Fade Mode; Auto (Program Run) Mode; Sound Active Mode and DMX-512 Mode
- 32 built-in Color Macros
- Beam Angle: 40 degrees / Power Draw: 56W Max
- IEC AC IN/OUT outlets on rear to daisy chain power
- Multi-voltage operation: AC 100V-240V 50/60Hz
- Dimensions (LxWxH): 13"x11"x4.25"/328x280x105mm
- Weight: 8 lbs./3.3 kg.

Specification

- Light Source: Ultra bright slim Par Can with 7x 3-Watt TRI LEDs (3-in-1 RGB)
- Smooth RGB color mixing (fast or slow color change operation)
- Snoot Frame included to help limit unwanted light exposure
- 7 DMX Channel modes: 1, 2, 3, 4, 5, 6 or 7 channel modes
- 6 Operational modes: Manual Color Mode; Color Change Mode; Color Fade Mode; Auto (Program Run) Mode; Sound Active Mode and DMX-512 Mode
- 32 built-in Color Macros
- Beam Angle: 40 degrees / Power Draw: 26.5W max
- IEC AC IN/OUT outlets on rear to daisy chain power
- Multi-voltage operation: AC 100V-240V 50/60Hz
- Dimensions (LxWxH): 10.75"x9"x4.25"/272x230x115mm
- Weight: 6 lbs./2.4 kg.

RGB Color Mixing:



RGB Color Mixing:



Photometric

R	D40	1320	850	155	82.2	51.5
G	D40	1060	285	116.6	66.9	43.8
B	D40	1113	308	126.5	74.8	46.6
RGB	D40	2920	791	355	193	123.5

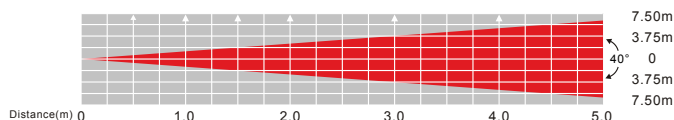

Photometric

R	D40	752	196	84	48.4	32.6
G	D40	473	135	58.6	35.5	23.5
B	D40	531	127	58.6	35.3	23.2
RGB	D40	1370	399	166.8	98.1	66.4

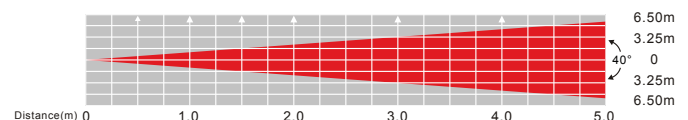



Compatible with:
ADJ LED RC2
(Sold Separately)
1226200027



1226100311



Compatible with:
ADJ LED RC2
(Sold Separately)
1226200027



1226100298

MEGA 64 PROFILE PLUS

MEGA TRIPAR PROFILE PLUS

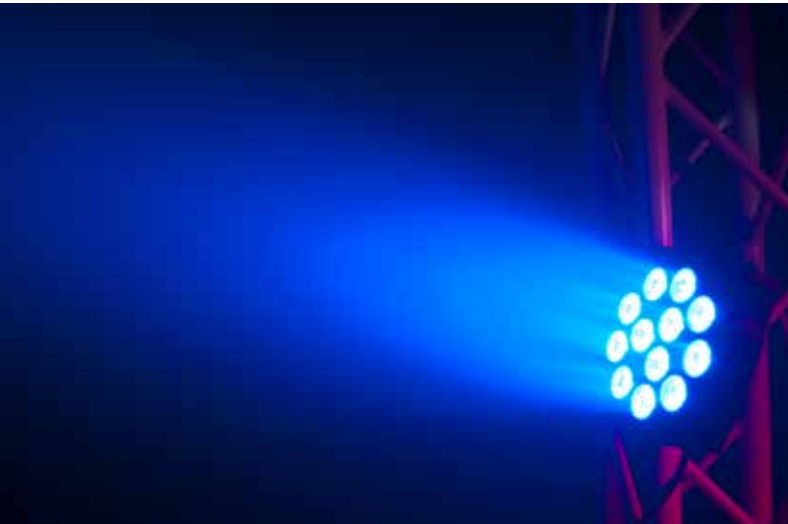

Specification

- Light Source: Ultra bright flat Par 64 with 12 x 4W Quad (RGB+UV 4-IN-1) LEDs
- Smooth RGB Color Mixing (fast or slow color change operation) with no RGB+UV shadows
- DMX-512 protocol / 5 DMX Channel modes: 4/5/6/9/10 channels
- 5 Operational modes: RGB+UV Dimmer Mode, Sound Active Mode, Auto Run Mode (16 Color Change Programs, 16 Color Fade Programs, & Color Change & Fade Combination), Static Color Mode, & DMX Controlled
- 64 built-in Color Macros
- Beam Angle: 25 degrees / Power Draw: 54W Max
- IEC AC input and output on rear to daisy chain power (Up to 12 Mega 64 Profile Plus fixture's)
- Multi-voltage operation: AC 100V-240V 50/60Hz
- Dimensions (LxWxH): 10.5" x 10.25" x 4.5" / 261 x 260 x 110mm
- Weight: 5 lbs./ 2.1 kg.

Specification

- Light Source: Ultra bright slim flat black Par with 5 x 4-Watt, 4-IN-1 Quad RGB+UV LEDs
- Smooth RGB color mixing (fast or slow color change operation)
- 5 DMX Channel modes: 4, 5, 6, 9 or 10 channel modes
- 5 Operational modes: Auto Run Mode (16 Color Change Mode, 16 Color Fade Modes, & 1 Combined Mode), Sound Active Mode (16 Modes), RGB + UV Dimmer Mode, Static Color Mode (64 Colors), and DMX Controlled
- 64 built-in Color Macros
- Beam Angle: 40 degrees / Power Draw: 21W max
- IEC AC input and out put on the side of the fixture to daisy chain the power cords (link up to 30 fixtures)
- Multi-voltage operation: AC 100V-240V 50/60Hz
- Dimensions (LxWxH): 8.75"x8.75"x3.25" / 225x220x85mm
- Weight: 2.7 lbs./ 1.23 kg.

RGB Color Mixing + UV:



RGB Color Mixing + UV:



Photometric

R	3940	1324	615	361	209	
G	2860	1014	424	230	149.9	(LUX)
B	3160	1158	440	240	148	
UV	862	243	112	61.4	39	
RGB+UV	11720	3520	1346	820	508	

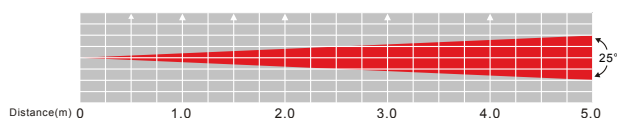

Photometric

R	D30	235	75	38	22	14	
G	D30	518	173	59	34	15	(LUX)
B	D30	530	176	76	38	27	
UV	D30	77	21	7	5.5	3.5	
RGB	D30	1298	318	156	84	56	
RGB+UV	D30	1327	345	165	92	58	

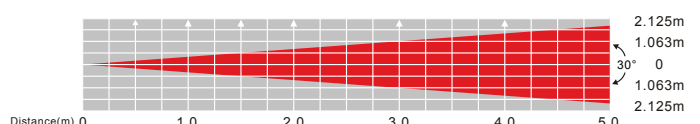



Compatible with:
ADJ LED RC3
(Sold Separately)
1226200046



FLAT PAR TW12

1226100277



Compatible with:
ADJ LED RC3
(Sold Separately)
1226200046



FLAT PAR TW5

1226100276



Specification

- 60W Dynamic White LED Flat Par
- 12x 5-Watt TRI LED 3-IN-1 CW/WW/A (Cool White/Warm White/Amber - 50,000 hrs.)
- 7 DMX Modes: 1, 2, 3, 4, 5, 6 & 7 channels
- TRI LEDs Eliminate color shadows when mixing Dynamic White LEDs
- LED pulse and strobe effect
- Electronic Dimming: 0 - 100%
- Beam angle: 40-degree
- 4-button, DMX digital display on rear panel
- Optional IR wireless remote control ADJ LED RC3 (sold separately)
- Dual yoke allows fixture to be hung or set on the ground
- Data linkable via 3-pin XLR cables
- Power Draw: 61W total (All LED's @ Full On)
- Multi-voltage operation: AC 100-240V, 50/60Hz (IEC power In/Out)
- Dimensions (LxWxH): 13" x 11" x 4.25" / 328 x 280 x 105mm
- Weight: 7.5 lbs. / 3.25 kg.

Specification

- 25W Dynamic White LED Flat Par
- 5x 5-Watt TRI LED 3-IN-1 CW/WW/A (Cool White/Warm White/Amber - 50,000 hrs.)
- 7 DMX Modes: 1, 2, 3, 4, 5, 6 & 7 channels
- TRI LEDs Eliminate color shadows when mixing Dynamic White LEDs
- LED pulse and strobe effect
- Electronic Dimming: 0 - 100%
- Beam angle: 40-degree
- 4-button, DMX digital display on rear panel
- Optional IR wireless remote control ADJ LED RC3 (sold separately)
- Dual yoke allows fixture to be hung or set on the ground
- Data linkable via 3-pin XLR cables
- Power Draw: 26W total (All LED's @ Full On)
- Multi-voltage operation: AC 100-240V, 50/60Hz (IEC power In/Out)
- Dimensions (LxWxH): 10.75" x 8.75" x 4.25" / 272 x 223 x 105mm
- Weight: 6 lbs. / 2.4 kg.

Cool, Warm White & Amber Color Mixing:
Color Temperature: >6500°K (Cool White); >2700°K (Warm White)

Cool, Warm White & Amber Color Mixing:
Color Temperature: >6500°K (Cool White); >2700°K (Warm White)

Photometric

WW	D40	2530	600	216	137.6	88.5
CW	D40	3220	796	350	196	128
Amber	D40	2020	507	218	123	79
WW/CW/A	D40	6760	1650	733	393	253

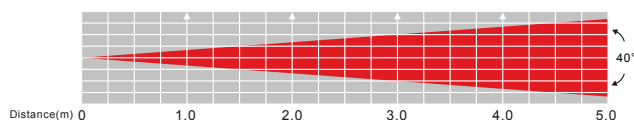

Photometric

WW	D40	1036	258	111	62	41
CW	D40	1470	350	151	83	54
Amber	D40	923	215	86.5	49.4	32
WW/CW/A	D40	2810	700	298	166	107

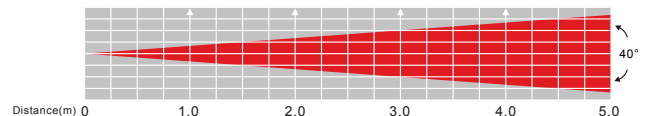



Remote Included

VPAR PAK

1226100280

DOTZ TPAR SYSTEM

1223200031



Pack Includes:
 2x VPAR LED Pars
 1x Soft Case Gig Bag
 1x ADJ LED RC2 IR Wireless Remote

Specifications:

- Ultra bright slim flat black Par with 5x 4-Watt, 4-IN-1 QUAD LEDs (RGBA) – casts no RGB shadows
- Smooth RGBA Color Mixing (fast or slow color change operation)
- Unique "sit-flat" design: Power & DMX Ins/Outs intelligently designed so the unit can be set flat on the ground or set inside truss
- Great as an architectural wall wash or for performance stages where traditional stage lighting emit a lot of heat onto performers
- 8 DMX Channel modes: 1, 2, 3, 4, 5, 6, 7 or 8 channels
- 5 Operational modes: RGBA Dimmer mode, sound active mode, static color mode, auto run mode (3 auto run modes), and DMX Control
- Digital DMX Display with 4-button menu for easy navigation
- Stand Alone or Master/Slave Configuration
- Beam Angle: 40 degrees
- 15 built-in Color Macros
- DMX-512 protocol
- Color strobe effect
- Linkable via 3-pin XLR cable
- Electronic Dimming: 0-100%
- Flicker Free
- Includes a scissor yoke to hang on truss, mount on a wall or set on the ground
- Long Life LEDs (50,000 hrs.)
- Power Draw: 21W Max
- IEC AC input and out put on the side of the fixture to daisy chain the power cords (link up to 30 fixtures)
- Compatible with ADJ LED RC2 wireless infrared remote control up to 30 ft./ 10M (included in the pak)
- Multi-voltage operation: AC 100V-240V 50/60Hz
- Dimensions (LxWxH): 225 x 220 x 85mm
- Weight: 1.2 kg.
- VPAR Gig Bag inner dimensions (LxWxH): 225 x 200 x 240mm
- System Weight: 3 kg.



Specification

- Light Source: 4 X 30W COB Tri RGB LEDs In separate adjustable fixtures
- Portable Wash/ Blinder stage lighting system with stand, travel bag, and foot controller
- Standard 90° or 25° kit included to adjust beam angle; 15 exciting built in programs
- DMX Modes : 3,6,7,12, or 18 channels: 3 PIN DMX In/Out
- Multi Voltage operation: AC 100-240V 50/60 Hz (IEC Input)
- Power Consumption: 1.31 Amps @ 110V; .65 Amps @ 220V
- System Dimensions (LXWXH): 39.5" x 12.75" x 3.25"/ 1000 x 320 x 82mm
- Weight: 35 lbs / 16kg



Photometric

Beam Angle 25°	R	2400	749	360	206	138	(LUX)
	G	2760	904	427	249	161	
	B	4130	1357	646	96	246	
	RGB	8650	2680	1345	372	506	
	Spot Diameter	0.65	1.08	1.83	1.97	2.41	

Field Angle 30°	R	2400	749	360	206	138	(LUX)
	G	2760	904	427	249	161	
	B	4130	1357	646	96	246	
	RGB	8650	2680	1345	372	506	
	Spot Diameter	0.83	1.45	2.10	2.70	3.35	

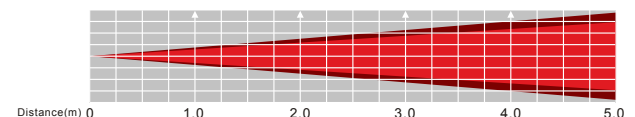



LED COLOR TUBE II

1211500011



MAGNA TUBE

1211500013



Specification

- 40-inch/ 1000mm LED Color Tube with UV-resistant polycarbonate tubing
- 32 Bright RGB TRI LEDs (3-in-1)
- 15 Exciting LED Colors plus White
- Rainbow color effect
- Each unit includes one easy-to-use wireless remote to control: Manual Color Change; Auto Color Change; Flash; Rainbow Effect; Slow to Fast Color Strobing; On/Off
- Includes AC power supply, two wall mounting brackets and base to stand LED Color Tube up vertically
- Long life LEDs (Rated at approximately 30,000 hrs.)
- Light Source: 32 x 0.2W TRI RGB's LEDs
- Power Draw: 6W total (All LED's @ Full On)
- Auto sensing power supply: DC 100V/60Hz - 240V/50Hz
- Dimensions (LxWxH): 40" x 2" x 2" / 1016 x 50 x 50mm
- Weight: 2 lbs. / 1 kgs.

The Magna Tube is a 1m plastic tube with a metallic, magnetic gel frame-adapter that fits almost any Flat Par with metal front-housing. The Magna Tube gel frame-adapter has 4 strong magnets that holds the Magna tube firmly to the metallic housing of a Flat Par.

Specification

- Accessory for ADJ Flat LED Pars & WiFLY LED Pars
- Includes 3-foot acrylic tube, magnetic metal frame adapter & silicon rubber cover
- Total Size: 8.25" x 8.25" x 39.75" / 208 x 208 x 1008mm
- Tube Size: Diameter 6" / 150mm; Height 39.5" / 1000mm
- Total Weight: 3.6 lbs / 1.64 kg
- Great alternative look to uplighting
- Magnets on metal adapter securely clips onto top metal part of LED Pars
- Compatible with the following ADJ Pars: Flat Par TRI7X, Flat Par TRI7XS, Flat Par QWH5X, Flat Par QWH5XS, Flat Par QA5X, Flat Par QA5XS, Flat Par TW5, WiFly EXR HEX Par, WiFly Par QA5, WiFly Par QA5 WH, WiFly EXR Hex Par

Do not use with halogen Par Cans



Compatible with
ADJ RFC
(Sold Separately)
1223200026



ULTRA HEX BAR 12

1226200047

ULTRA HEX BAR 6

1226200044



Specification

- Light Source: 12 x 10W Ultra bright HEX (RGBAW + UV: 6-IN-1) color mixing LEDs
- 5 DMX Channel Modes: 6, 7, 8, 12 or 36 channels
- 6 operational modes: Auto Run, Program Mode, Sound Active, RGBAW + UV Dimmer, Static Color and DMX-512 Mode
- Beam Angle: 40 degrees
- 63 built-in Color Macros
- 5 selectable Dim Curves (Standard, Stage, TV, Architectural & Theatre)
- Power Draw: 90W
- Linkable: DMX via 3-pin XLR cable; Power via IEC daisy-chain-power link
- Multi-voltage operation: AC 100V-240V 50/60Hz
- Dimensions (LxWxH): 1020 x 70 x 122mm
- Weight: 4.74 kg.



"Quick Align"
Magnetic Ends

Specification

- Light Source: 6x 10W Ultra bright HEX (RGBAW + UV: 6-IN-1) color mixing LEDs
- 5 DMX Channel Modes: 6, 7, 8, 12 or 18 channels
- 6 operational modes: Auto Run, Program Mode, Sound Active, RGBAW + UV Dimmer, Static Color and DMX-512 Mode
- Beam Angle: 40 degrees
- 63 built-in Color Macros
- 5 selectable Dim Curves (Standard, Stage, TV, Architectural & Theatre)
- Power Draw: 55W
- Linkable: DMX via 3-pin XLR cable; Power via IEC daisy-chain power link
- Multi-voltage operation: AC 100V-240V 50/60Hz
- Dimensions (LxWxH): 23" x 4.5" x 6.5" / 585 x 110 x 165mm
- Weight: 6 lbs./ 2.82 kg.



"Quick Align"
Magnetic Ends

RGBAW Color Mixing + UV:



RGBAW Color Mixing + UV:



Photometric

R	D40	823	335	176	103.9	65.6
G	D40	968	338	183	104.8	64.7
B	D40	874	328	168	95.8	60.8
W	D40	1303	552	269	148	96.8
A	D40	529	201	95.7	53.9	35.4
UV	D40	192	80.2	39.2	22.4	14.8
RGBAW+UV	D40	3880	1680	810	478	286

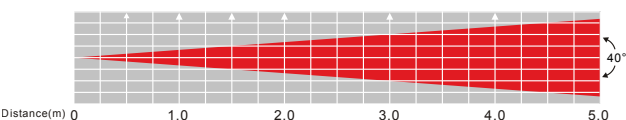

Photometric

R	D40	794	248	91.3	55.5	34.8
G	D40	868	282	110.7	62.7	39.6
B	D40	827	259	91.5	56	35.4
W	D40	1185	396	174.7	87.3	63.3
A	D40	466	143.2	63.8	37.3	24.3
UV	D40	147.6	48.8	21.6	12.4	8
RGBAW+UV	D40	3710	1172	566	310	188.4

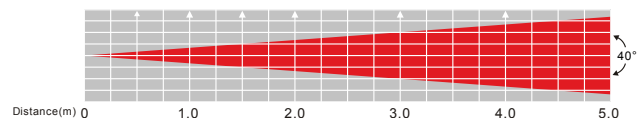



ADJ RFC
(Sold Separately)
1223200026

VBAR PAK

1226100281

ULTRA BAR 12

1226200041

Pack Includes:

- 2x VBAR LED Linear Fixtures
- 1x ADJ LED RC2 IR
- 1x Soft Case Gig Bag
- Wireless Remote

Specifications:

- Ultra bright, compact black Linear fixture with 5x 4-Watt, 4-IN-1 QUAD LEDs (RGBA) casts no RGB shadows
- Smooth RGBA Color Mixing (fast or slow color change operation)
- Great as an architectural wall wash or for performance stages where traditional stage lighting emit a lot of heat onto performers
- 8 DMX Channel modes: 1, 2, 3, 4, 5, 6, 7 or 8 channels
- 5 Operational modes: RGBA Dimmer mode, sound active mode, static color mode, auto run mode (3 auto run modes), and DMX Control
- Digital DMX Display with 4-button menu for easy navigation
- Stand Alone or Master/Slave Configuration
- Beam Angle: 40 degrees
- 15 built-in Color Macros
- DMX-512 protocol
- Color strobe effect
- Linkable via 3-pin XLR cable
- Electronic Dimming: 0-100%
- Flicker Free
- Adjustable mounting brackets; mount on a wall or set on the ground
- Long Life LEDs (50,000 hrs.)
- Power Draw: 21W Max
- IEC AC input and out put on the side of the fixture to daisy chain the power cords (link up to 30 fixtures)
- Compatible with ADJ LED RC2 wireless infrared remote control up to 30 ft./ 10M (included in the pak)
- Multi-voltage operation: AC 100V-240V 50/60Hz
- Dimensions (LxWxH): 560 x 63 x 90mm
- Weight: 1.7 kg.
- VBAR Gig Bag inner dimensions (LxWxH): 560 x 165 x 90mm
- System Weight: 4 kg.

Specification

- Light Source: 12 x 3W Ultra Bright Tri (3 in 1) RGB LEDs
- 41.75" (1 meter) Linear Bar with 3 or 6 section Pixel Control
- 40° Vertical Beam Angle for wide coverage pattern; smooth color mixing
- DMX Modes : 3,5,6,7,8,9,11,18 or 20 channels: 3 PIN DMX In/Out
- IEC AC In/Out (Power daisy chain 13 units @110V, 20 units @220V)
- Power Draw: 43W
- Dimensions (LXWXH): 41.75" x 2.5" x 3.75"/ 1060 x 63 x 90mm
- Weight: 6 lbs/ 2.7 kg



"Quick Align"
Magnetic Ends

RGB Color Mixing:



Photometric

	R	1721.8	623.6	306	198.8	129.3	
	G	1736.4	625.5	298.4	189.5	110.3	
	B	1918.2	650.9	279	177	120.8	(LUX)
Beam Angle 40°	RGB	4909.1	1794.5	833	535	356	

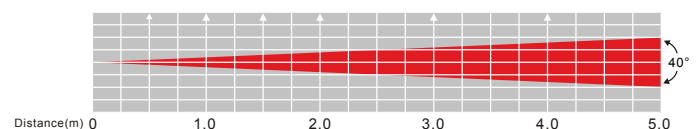



ADJ RFC
(Sold Separately)
1223200026



ADJ RFC
(Sold Separately)
1223200026



ULTRA BAR 9

1226200040

ULTRA BAR 6

1226200039



Specification

- Light Source: 9 x 3W Ultra Bright Tri (3 in 1) RGB LEDs
- 41.75" (1 meter) Linear Bar with 3 section Pixel Control
- 40° Vertical Beam Angle for wide coverage pattern; smooth color mixing
- DMX Modes : 3,5,6,7,8,9 or 11 channels: 3 PIN DMX In/Out
- IEC AC In/Out (Power daisy chain 15 units @110V, 28 units @220V)
- Power Draw: 35W
- Dimensions (LXWXH): 41.75" x 2.5" x 3.75" / 1060 x 63 x 90mm
- Weight: 6 lbs/ 2.6 kg



"Quick Align"
Magnetic Ends

Specification

- Light Source: 6 x 3W Tri (3 in 1) RGB LEDs
- 22.5" (.5 meter) Linear Bar with 3 section Pixel Control
- 40° Vertical Beam Angle for wide coverage pattern; smooth color mixing
- DMX Modes : 3,5,6,7,8,9 or 11 channels: 3 PIN DMX In/Out
- IEC AC In/Out (Power daisy chain 25 units @110V, 40 units @220V)
- Power Draw: 22W
- Dimensions (LXWXH): 22.5" x 2.5" x 3.75" / 560 x 63 x 90mm
- Weight: 4 lbs/ 1.6 kg



"Quick Align"
Magnetic Ends

RGB Color Mixing:



RGB Color Mixing:



Photometric

R	818	315	166.9	105.2	72.6	(LUX)
G	747	270	173	111	72	
B	974	325	165.5	107.3	76.3	
RGB	2574	934	519	322	198	

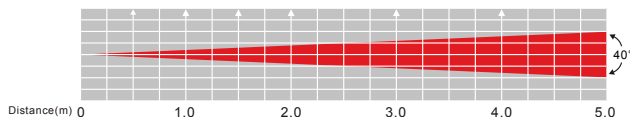

Photometric

R	947	343	173	91.5	59.7	(LUX)
G	955	344	164.2	87.8	56.1	
B	1055	358	175	92.2	60.2	
RGB	2700	987	481	272	163.7	

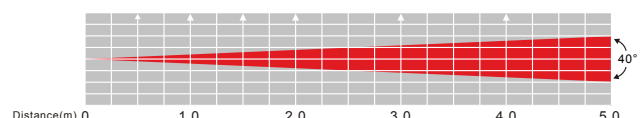

LED EFFECTS





NEW! PENTA PIX

1237000164

COLOR STRAND

1226100334



Specification

- New ACL (Advanced Collimator optic Lens) for razor sharp 6-degree beams
- 5-Zone Pixel Control
- 15 exciting built-in Lightshows with sound active control
- Runs extremely cool! - NO Duty Cycles! - Run all night!
- 5 selectable Dimmer Curves
- Includes scissor yoke + safety hook on rear panel
- 4-Button DMX LED Display
- 5x 15-Watt 4-in-1 RGBW Quad LEDs
- 5 Operational modes: Sound Active, Auto Run, RGBW Dimmer Mode, Color Macro Mode, & DMX Control
- 63 Preset Color Macros
- 3 DMX Channel modes: 4/6/22 DMX channels
- 3-Pin DMX In/Out connections
- Strobe speed (Controlled via DMX)
- 0-100% electronic dimming (Controlled via DMX)
- Power Consumption: 77W maximum
- AC Connection: PowerCON IN/OUT; Daisy chain power
- Multi-voltage operation: AC 100-240V 50/60Hz
- Dimensions (LxWxH): 21" x 11" x 10.25" / 530 x 280 x 260mm
- Weight: 12 lbs. / 5.4 kg.

Specification

- 6W RGBW/WW (RGB @ 1W, WW @ 3W)
- 20 replaceable bulbs included on a 30ft/10m strand
- Remote included
- Linkable up to 20 units for a total of 60ft/200m strand
- IP Rating: IP44



Color Strand RGBW
RF Remote
1226100336



NEW!**BOOM BOX FX 1**

1237000168

NEW!**BOOM BOX FX 2**

1237000169

**Specification**

- High Output 4-FX-IN-1: One Dome effect, one Derby effect, one Strobe/Chase and one green & red Laser effect
- 2 DMX Channel Modes: 3 Channels & 22 DMX Channels
- 3 Operation modes: Sound Active, Show Mode or DMX Controllable
- 9 Exciting built-in shows
- Produces 63 Preset Color Combinations
- Stand Alone or Master/Slave Set Up
- Linkable via 3-pin XLR cable
- 4-button DMX display on rear panel
- Strobe & Chase LED Effect
- DMX-512 Protocol
- NO Duty Cycles! - Run all night!
- IEC AC IN/OUT on rear to daisy chain power (8 Fixtures Max. @ 120V and 16 Fixtures Max. @230V)
- Power Draw: 66W Max (Full On)
- UC IR Remote Control (Sold Separately) & Airstream IR Compatible
- Multi Voltage: 100V ~ 240V, 50/60Hz
- Long life LEDs (Rated at approximately 50,000 hours)
- Light Source: Dome: 6 x 3W LEDs (1 Red, 1 Green, 1 Blue, 1 White, 1 Amber, & 1 UV); Wash: 8 x 1W LEDs (2 Red, 2 Green, 2 Blue, & 2 Amber); Derby Effect: 2 x 10W Quad LEDs (RGBW) + Red & Green Laser
- Dimensions (L x W x H): 9.5" x 25" x 12.5" / 239 x 634 x 319mm
- Weight: 14.2 lbs. / 6.5kg.

Specification

- High Output 4 FX in 1: Gobo Effect, Moonflower Effect, Strobe/Chase and green & red laser effect
- 2 DMX Channel Modes: 3 Channels & 18 DMX Channels
- 3 Operation modes: Sound Active, Show Mode or DMX Controllable
- 8 Gobos
- 9 Exciting built-in shows
- Stand Alone or Master/Slave Set Up
- Linkable via 3-pin XLR cable
- 4-button DMX display on rear panel
- Strobing
- DMX-512 Protocol
- NO Duty Cycles! - Run all night!
- Safety Loop on rear panel
- UC IR Remote Control (Sold Separately) & Airstream IR Compatible
- Power Draw: 62W Max (Full On)
- Multi Voltage: 100V ~ 240V, 50/60Hz
- Long life LEDs (Rated at approximately 50,000 hours)
- Light Source: Gobos: 8 x 3W LEDs (2 Red, 2 Green, 2 Blue, & 2 White); Derby Effect: 2 x 10W Quad LEDs (RGBW); Wash: 8 x 1W LEDs (2 Red, 2 Green, 2 Blue & 2 Amber) + Red & Green Laser
- Dimensions (L x W x H): 9" x 25" x 12.5" / 232 x 634 x 319mm
- Weight: 15.5 lbs. / 7kg.

Startec
 SERIES
 by ADJ

STINGER GOBO

1237000150

Startec
 SERIES
 by ADJ

STINGER STAR

1237000149

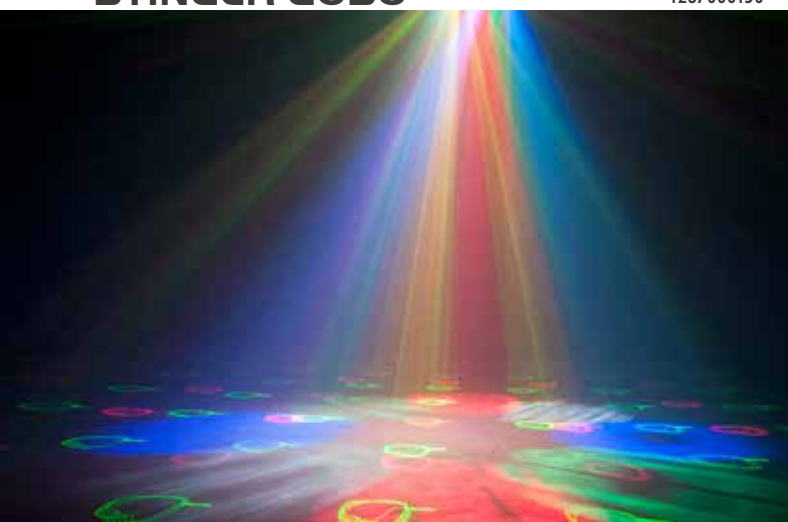
Specifications

- High Output 3 FX in 1: Gobo Effect, Strobe/Chase and Laser effect with 8 x 3W RGBW LED's + 8 x 1W RGBA LED's + Red & Green Lasers
- 2 DMX Channel Modes: 2 and 14 DMX Channels
- 3 Operation modes: Sound Active, Show Mode or DMX Controllable
- 8 Gobos
- 6 Exciting built-in shows
- Produces 15 Preset Color Combinations
- Stand Alone or Master/Slave Set Up
- Linkable via 3-pin XLR cable
- 4-button DMX display on rear panel
- Strobing
- DMX-512 Protocol
- NO Duty Cycles! - Run all night!
- IEC AC IN/OUT on rear to daisy chain power (8 Fixtures Max. @ 120V and 16 Fixtures Max. @230V)
- Safety Loop on rear panel
- UC IR Remote Control (Sold Separately) & Airstream IR Compatible
- Power Draw: 55W Max (Full On)
- Multi Voltage: 100V ~ 240V, 50/60Hz

Specifications

- High Output 3 FX in 1: Moonflower, Strobe/Chase and Laser effect with 6 x 3W RGBWAV LED's + 8 x 1W RGBA LED's + Red & Green Lasers
- 2 DMX Channel Modes: 2 and 14 DMX Channels
- 3 Operation modes: Sound Active, Show Mode or DMX Controllable
- 6 Exciting built-in shows
- Produces 63 Preset Color combinations
- Stand Alone or Master/Slave Set Up
- Linkable via 3-pin XLR cable
- 4-button DMX display on rear panel
- Strobe & Chase LED Effect
- DMX-512 Protocol
- NO Duty Cycles! - Run all night!
- IEC AC IN/OUT on rear to daisy chain power (8 Fixtures Max. @ 120V and 16 Fixtures Max. @230V)
- Safety Loop on rear panel
- Power Draw: 55W Max (Full On)
- Multi Voltage: 100V ~ 240V, 50/60Hz
- Long life LEDs (Rated at approximately 50,000 hours)
- UC IR Remote Control (Sold Separately) & Airstream IR Compatible
- Light Source: 6 x 3W RGBWAV + 8 x 1W RGBA LED's + Red & Green Laser
- Dimensions (L x W x H): 16.25" x 8.25" x 9.5" / 410x210x238mm
- Weight: 4.4kg.



Startec
SERIES
by ADJ



STINGER II

1237000133

STINGER

1237000113



Specification

- Light Source: 6 x 5W RGBA + White & Pink LED's + 8 x 3W UV LED's + Red & Green Laser
- 1.8 Degree Long Life Stepper motor Technology
- Produces 15 Preset Colors / Strobe & Pulse LED Effect / Electronic Dimming: 0 - 100%
- DMX Modes : 2 DMX Channel modes: 2 Channels & 9 Channels / Linkable via 3-pin XLR cable
- 3 Operation modes: Sound Active, Master/Slave or DMX Controllable
- Compatible with ADJ UC IR Remote (sold Separately)
- I.E.C. In & Out to Daisy chain Power (Connect up to 10 Fixtures)
- Multi Voltage operation: 100V~240V, 50/60Hz
- Power Consumption: 70W
- Dimensions (L x W x H): 12" x 9" x 12.25" / 304x230.5x313mm
- Weight: 11 lbs. / 5kg.

Specification

- Description: 3-FX-IN-1: Moonflower effect, Strobe Effect & Red/Green Laser
- Light Source: 6 x 5W RGBAW+Purple LED's + 8 x 3W White LED's + Red & Green Laser
- DMX Mode: 10 DMX Channels; 3 Pin I/Out
- Operating Modes: Auto Run, Sound Active, & DMX Control, Master/Slave, Stand Alone
- Features: LED Effect Light, Strobe Effect, 2 Color Red/Green Laser
- Power Draw: 70W Max; .64 amp@ 110v, .32 amp@220v
- Power: IEC In/IEC Out, Power link units
- Multi voltage operation: 100V-240V, 50/60Hz
- Dimensions (LxWXH): 12" x 9"x 9.75" / 304x230.5x9.75mm
- Weight: 11 lbs. / 5kg.

STINGER 3-FX-IN-1

STINGER 3-FX-IN-1



StarTec
SERIES
by ADJ



STARBURST

1211500012

REVO 4 IR

1222400089



Specification

- 5 x 15W 5-in-1 RGBWY+Purple LEDs
- Produces 34 crisp, bright beams
- Beam Angle: 1 Degree
- 12 DMX Channels
- 3 operational modes: Auto Run, Sound Active, DMX Controlled
- Stand Alone or Master-Slave Set-Up
- IEC Power Cord Daisy Chain 20 units @ 120V
- Multi-voltage operation: AC 100~240V, 50/60Hz
- Power Consumption: 55W
- Dimensions (LxWxH): 12.5" x 12.5" x 16.25" / 318 x 318 x 412.5mm
- Weight: 8 lbs. / 3.65 kgs.

Specification

- LED DMX-512 Moonflower from the popular REVO Series with 256 razor sharp Red, Green, Blue & White Beams
- Light Source: 256 total 5mm LEDs : 64 Red, 64 Green, 64 blue and 64 White
- 2 DMX Channel Modes (4 Channel mode or 256 Channel mode)
- Beam angle: 35 degrees
- 3 operation modes: DMX, Sound Active & Master/Slave
- Includes hanging bracket
- Strobe function
- IEC AC IN/OUT on rear to daisy chain power (up to 12 fixture's @ 120V and 21 fixture's @ 230V)
- Power Consumption: 34W maximum
- Multi-voltage operation: AC 100-240V, 50/60Hz
- Dimensions (LxWxH): 12.25" x 12" x 13.25" / 312 x 306 x 334 mm
- Weight: 11 lbs. / 4.9 kgs



UC-IR
(Sold Separately)
1321000074



AIRSTREAM IR
1226100319

Startec
SERIES
by ADJ



MINI DEKKER

1222400087

Startec
SERIES
by ADJ



MINI DEKKER LZR

1222400090

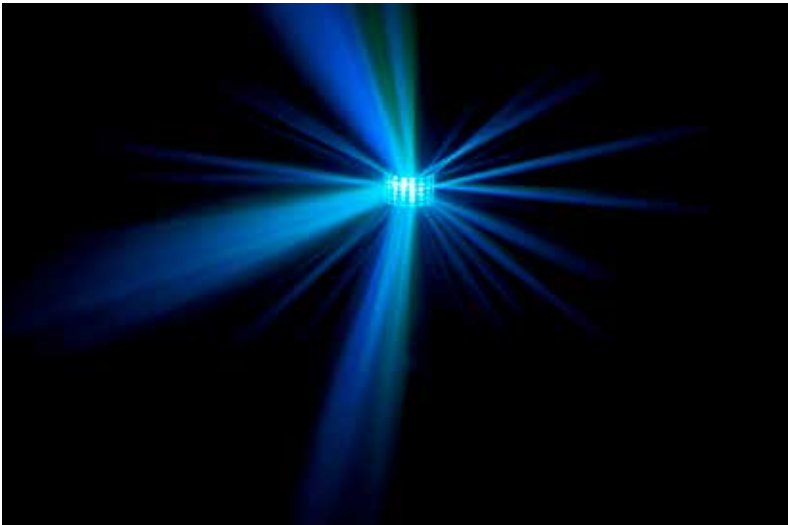

Specification

- LED effect that produces RGBW (red, green, blue & white) colored beams from 48 lenses
- Light Source: 2 bright 10-watt RGBW Quad LED's
- Operational Modes: Color Change, Color Fade, Color Change w/ Strobe, Color Fade w/ Strobe, Sound Active, Static Color, & DMX Control
- DMX Channels: 8 Channel ; 3 Pin In/Out
- Features: Sound Active, Strobe Effect, Multi Color Beams
- Power consumption: 25W maximum
- Multi-voltage operation: AC 100V-240V 47/63Hz
- In/Out IEC power connections to daisy-chain power
- Dimensions per unit (LxWxH): 7.75" x 7.5" x 9.75" / 197x184x245mm
- Weight: 3.74 lbs. / 1.7kg.



Specification

- DMX-512 LED effect that produces RGBW (red, green, blue & white) colored beams from 48 lenses
- 2 DMX Channel Modes: 2 Channel and 7 Channel
- Features 2 bright 10-watt RGBW Quad LED's, Green Laser: 30mW (532nm) Green laser, Red Laser: 100mW (650nm) Red laser
- Complies with FDA standards
- Multiple unique laser patterns
- Light in weight and portable for entertainers on the go!
- Strobe effect
- 3 Operating Modes: Show Mode, Sound Active, & DMX Control
- 3 Show Modes with adjustable speed control
- DMX-512 protocol
- UC IR & Airstream IR Compatible (Sold Separately)
- 4-button DMX LED menu
- Stand Alone or Master/Slave Configuration
- Includes hanging bracket
- Run all night - no duty cycle
- Power consumption: 33 W maximum
- Multi-voltage operation: AC 100V-240V 50/60Hz
- Dimensions per unit (LxWxH): 8" x 7.75" x 8.5" / 205 x 198 x 218mm (with Bracket) 8" x 7.75" x 5.75" / 205 x 198 x 147mm (without Bracket)
- Weight (per unit): 4 lbs. / 1.7kg.

QUAD PHASE HP

1122100253

Specification

- Light Source: 1 x 32W High Powered RGBW (Red, Green, Blue, White) Quad LED
- High output moonflower effect with dozens of razor sharp beams of light
- 4 DMX Channels (Color, Rotation, Strobe, Dimmer); 3 Pin DMX IN/Out
- 65° beam angle; Built in programs, Strobe, Pulse effect
- IEC AC In/Out (Power daisy chain 5 units @110V, 9 units @220V)
- Max Power Draw: 64W
- Dimensions (LXWXH): 12.5" x 8.0" x 11.0" / 312 x 198 x 279mm
- Weight: 9 lbs/ 4.0 kg

Compatible with UC3 Series
UC3 Universal Controller



ADJ RCI (Included)



VERTIGO HEX LED

1222300015

Specification

- Light Source: 2 x 12W HEX RGBCAW (Red, Green, Blue, Cyan, Amber, White) LEDs
- Classic ADJ effect now with six color LED light source for additional color output
- 60 Sound activated beams move to the sound of the music
- Long Life LEDs rated at approximately 50,000 hours
- IEC AC In/Out (Power daisy chain 10 units @110V, 15 units @220V)
- Max Power Draw: 30W
- Dimensions (LXWXH): 13.75" x 10.75" x 11.75" / 345 x 272 x 294mm
- Weight: 7.0 lbs/ 2.75 kg

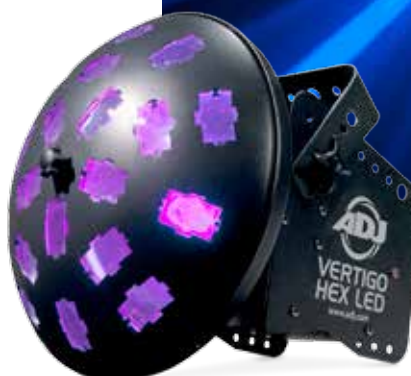

MINI TRI BALL II

1212300018

Specification

- Light Source: 2 x 3W RGB (Red, Green, Blue) Tri LED
- Mini Rotating Ball produces 56 sound activated multi colored beams of light
- 3 Position FX control (Constant Rotation, No Rotation, Sound Active Rotation)
- 180° Beam Angle; Long life LED (100,000 Hr. rating)
- Ball rotation: 15 RPM
- Max Power Draw: 13W
- Dimensions (LXWXH): 7.75" x 7.75" x 11.75" / 195 x 195 x 295mm
- Weight: 3 lbs/ 0.96 kg



MICRO GOBO II

1237000127

Specification

- Projects 8 different gobo patterns with more than 200 green and red laser beams that rotate back and forth
- Light Source: Green Laser: 30mW (532nm) Green laser, Red Laser: 80mW (650nm) Red laser
- Includes a laser safety key on rear
- 3 operational modes: Fast Auto Show, Slow Auto Show or Sound Active Mode
- Includes UC Laser IR
- Power consumption: 9W max
- Includes UL Listed multi-voltage power supply: AC 100-240V, 50/60Hz
- Dimensions (LxWxH): 5" x 6.75" x 5" / 130 x 172 x 130mm
- Weight: 2 lbs. / 0.6 kg.



Includes ADJ UC-IR infrared wireless remote control.



MICRO 3D II

1223200043

Specification

- Produces a 3D Laser effect with more than 200 green and red laser beams that rotate back and forth
- Light Source: Green Laser: 30mW (532nm) Green laser, Red Laser: 80mW (650nm) Red laser
- Includes a laser safety key on rear
- 2 operational modes: Auto Mode (built-in programs), or Sound Active Mode
- Includes UC Laser IR Remote Control & Airstream IR (Transmitter Included)
- Power consumption: 9W max
- Includes UL Listed multi-voltage power supply: DC 12V
- Dimensions (LxWxH): 5.25" x 6.75" x 5.25" / 130x172x130mm
- Weight: 2 lbs. / .6 kg.



Includes ADJ UC-IR infrared wireless remote control.

Includes AIRSTREAM IR



MICRO GALAXIAN II

1223200041

Specification

- Produces more than 200 green and red laser beams
- Light Source: Red Laser: 80mW (650nm) Red laser, Green Laser: 30mW (532nm) Green laser
- Includes a laser key on rear
- 2 operational modes: Auto Mode (built-in programs), or Sound Active Mode
- UC Laser IR Included
- Power consumption: 9W max
- Includes UL Listed multi-voltage power supply: AC 100-240V, 50/60Hz
- Dimensions (LxWxH): 5" x 6.75" x 5" / 130 x 172x 130mm
- Weight: 2 lbs. / .6 kg



Includes ADJ UC-IR infrared wireless remote control.



LASER EMERGENCY SWITCH 1237000126

The use of lasers of class 3B is permitted only by trained personnel in various countries.

Furthermore, in several countries, an additional emergency switch is mandatory. This emergency switch is inserted between the electrical wall outlet and the laser power supply to be able to switch off the laser in case of malfunction.





MICRO ROYAL GALAXIAN II 1223200044



ANI-MOTION 1223200046



Specification

- Unique mini laser that projects more than 200 blue and red beams
- 2 operational modes: Auto Mode (built-in programs), or Sound Active Mode
- Red Laser: 80mW (650nm) Green Laser - Blue Laser: 60mW (450nm) Red Laser
- Includes UC Laser IR Remote Control & Airstream IR (Transmitter Included)
- Power Consumption: 9W max
- Includes UL Listed multi-voltage power supply: DC 12V
- Dimensions (LxWxH): 5"x6.75"x5" / 130x172x130mm
- Weight: 0,8 kg.

Please note: This product is only for professional use according to the laws of your country

Specification

- Unique mini laser that projects red and green geometric patterns
- 36 dynamic patterns and 22 static effects are projected over a dance floor, ceiling or wall
- Compact case design
- 2 operational modes: Auto Mode (built-in programs), or Sound Active Mode
- Built-in programs can be changed with a push of a button on the unit or from the UC Laser IR wireless remote
- Dual bracket yoke allows fixture to be hung or set on the ground
- Sound Active
- Fan cooled
- Red Laser: 80mW (650nm) Red laser
- Green Laser: 30mW (532nm) Green laser
- Includes UL Listed multi-voltage power supply: AC 100V ~ 240V, 50/60Hz
- Includes UC Laser IR Wireless Remote Control [Auto Fast/Auto Slow/Sound Control; Black Out;
- Pattern Change and speed adjustment (R, R+G, G, R+G and Random]
- Power Consumption: 20W
- Complies with FDA standards
- Dimensions (LxWxH): 6.75" x 7.75" x 6.5" / 172 x 198 x 167mm
- Weight: 2.6 lbs. / 1.2 kg.

Please note: This laser effect is for DJ and home use, not intended for commercial use.



Included UC Laser IR wireless remote control.



Included UC Laser IR wireless remote control.



UV & STROBE EFFECTS



UV COB CANNON

1224100006

Specification

- Light Source: 100W COB (Chip On Board) UV LED engine
- Advanced COB Technology (Chip On Board) produces powerful, smooth UV color
- 3 Operation modes: Sound Active, Manual, & DMX
- 3 DMX Channel modes: 1, 2 or 3 channel
- Flicker Free operation (No flickering on camera)
- 5 selectable Dim Curves (Standard, Stage, TV, Architectural & Theatre)
- Beam angle: 33 degrees
- DMX Linkable: 3-pin XLR data connectors
- Power Linkable: PowerCon connectors
- (Up to 3 UV COB Cannon's @ 120V, 5 UV COB Cannon's @ 220V fixtures)
- Power Draw: 120W total (All LED's @ Full)
- Multi-voltage Operation: Auto switching, AC 100V - 240V/50Hz -60Hz
- Dimensions (LxWxH): 12.75" x 11" x 8" / 320 x 278 x 200mm
- Weight: 11 lbs. / 4.98kgs



UV FLOOD 36

1226200049

Specification

- Light Source: 12 x 3W UV LEDs (Rated at approximately 50,000 hours)
- Operational Modes: Sound Active, Dimmer Mode, and DMX Controlled
- Beam Angle: 57-Degrees
- 3 DMX Modes: 1/2/3
- DMX Connections: 3-Pin DMX In / Out DMX Connections
- Dimming: Electronic Dimming 0-100%
- Strobe Effect
- Strobe Rate: Adjustable
- Optional Accessory: Compatible with the Dotz Par RF wireless remote (sold separately)
- Power Consumption: 35W (Full on)
- Input Voltage: AC 100V-240V 50/60Hz
- Dimensions: 11.75" x 9.25" x 4.5" / 300 x 235 x 115mm
- Weight: 5lbs / 2.2 kgs



Compatible with:
ADJ PAR RF
(Sold Separately)
1223200035



FLASH ROPE

12515200013

Specification

- User Friendly "plug and play" strobe lighting with 12 flash capsules
- Built-in "O" ring for easy hanging
- Flash Rate: 1 flash per second
- Lamp Life: 2,000 hours (average)
- Power Consumption: 45W
- Length: 15.5 feet / 4760mm
- Weight: 1.75 lbs. / 0.8 kgs.



ECO UV BAR DMX

1224100005

Specification

- Light Source: 18 x 3W High Output Ultra Violet LED
- Black light effect in a linear fixture with DMX control
- 3 DMX Channels ; 3 Pin DMX IN/Out
- 120° beam angle; Built in programs, Strobe, Pulse effect
- IEC AC In/Out (Power daisy chain 10 units @110V, 15 units @220V)
- Power Consumption: .47 Amps @ 110V; .24 Amps @ 220V
- Dimensions (LxWxH): 39.5" x 2.5" x 4.75" / 1000 x 60 x 115mm
- Weight: 5 lbs/ 2.3 kg



ECO UV BAR 50 IR

1214100003

Specification

- Bright, high output ultraviolet bar with 9x 3-Watt UV LEDs
- Great for performance stages, theatrical productions and special effects installations
- On/Off switch on rear panel
- Beam Angle: 120-degree
- LED Strobe effect
- Adjustable mounting brackets for wall/ceiling mount or to set on the floor for wall washing
- Includes UC-IR Remote (Control: On/Off and Strobe Speed)
- Long Life LEDs (Rated at approximately 50,000 hrs.)
- Power Draw: 30W
- Multi-voltage operation: AC 100V-240V 50/60Hz
- Light Source: 9x 3-Watt UV LEDs
- Wavelength: 390-410nm
- Dimensions (LxWxH): 19.75" x 2.5" x 4.5" / 500 x 60 x 115mm
- Weight: 3.2 lbs. / 1.44 kgs

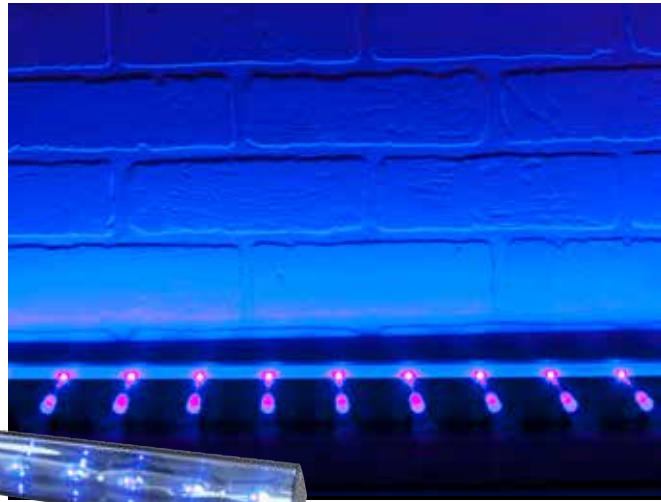

ECO UV BAR PLUS IR

1214100004

Specification

- Bright, high output ultraviolet bar with 18x 3-Watt UV LEDs
- Great for performance stages, theatrical productions and special effects installations
- On/Off switch on rear panel
- Beam Angle: 120-degree
- LED Strobe effect
- Includes mounting brackets for wall/ceiling mount or to set on the floor for wall washing
- Includes UC IR Remote (Rev. Nov. 2016)
- IEC Power In/Out with pigtails (Rev. Nov. 2016)
- Long Life LEDs (Rated at approximately 50,000 hrs.)
- Power Draw: 60W
- Multi-voltage operation: AC 100V-240V 50/60Hz
- Light Source: 18x 3-Watt UV LEDs
- Wavelength: 395-405nm
- Dimensions (LxWxH): 39.5" x 2.5" x 4.5" / 1000 x 60 x 110.5mm
- Weight: 6 lbs. / 2.4 kgs

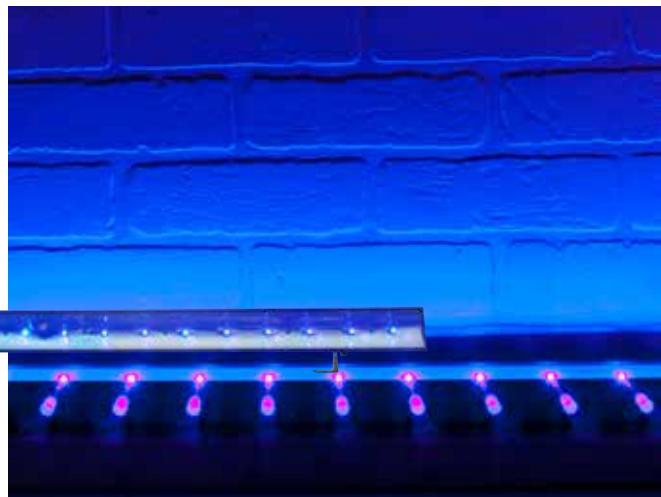



GOBO PROJECTORS & FOLLOWSPOTS/ PINSPOTS





UC-IR
(Sold Separately)
132100074



AIRSTREAM IR
1226100319



1237000134

ENCORE PROFILE 1000 WW



UC-IR
(Sold Separately)
132100074



AIRSTREAM IR
1226100319



1237000135

ENCORE PROFILE 1000 COLOR



Specification

- Pro Ellipsoidal with a 120W High Powered WW COB LED source, 3000°K, CRI: 98
- 12° - 30° Beam angle
- Stand Alone Setup or Master-Slave Setup
- 3 DMX Channel Modes: 1/2/3
- 4 gobos included
- Manual focusing
- Manual Zoom
- Manual Framing Shutters
- PowerCon In and Out for daisy chaining (Connect up to 5 Fixtures)
- 3 and 5 Pin DMX
- Compatible with UC-IR Remote
- Power Consumption: 144W maximum
- Multi-voltage operation: AC 100-240V 50/60Hz (non switchable)
- Dimensions (LxWxH): 560 x 250 x 385mm
- Weight: 8.5 kg.

Specification

- Pro Ellipsoidal with a 120W High Powered RGBW 4-in-1 COB LED source
- 12° - 30° Beam angle
- Stand Alone Setup or Master-Slave Setup
- 5 DMX Channel Modes: 4/5/6/10/11
- 64 static color presets
- 4 gobos included
- Manual focusing
- Manual Zoom
- Manual Framing Shutters
- PowerCon In and Out for daisy chaining (Connect up to 5 Fixtures)
- 3 and 5 Pin DMX
- Compatible with UC-IR Remote
- Power Consumption: 144W maximum
- Multi-voltage operation: AC 100-240V 50/60Hz (non switchable)
- Dimensions (LxWxH): 560 x 250 x 385mm
- Weight: 8.5 kg.

RGBW Color Mixing:



Photometric

	0.5m	1m	2m	3m	4m	5m	Diameter (Meters)
12°	0.11	0.22	0.44	0.66	0.88	1.10	(LUX)
WW	94800	30700	5970	2640	1514	958	

	0.5m	1m	2m	3m	4m	5m	Diameter (Meters)
30°	0.25	0.50	1.00	1.50	2.00	2.50	(LUX)
WW	39600	6760	1346	640	345	209	

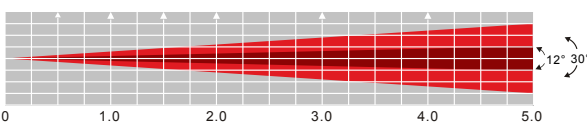

Photometric

	0.5m	1m	2m	3m	4m	5m	Diameter (Meters)
12°	0.11	0.22	0.44	0.66	0.88	1.10	(LUX)
R	26100	7640	1898	807	452	289	
G	21200	6230	1356	600	318	201	
B	22400	6340	1611	729	392	246	
A	9460	2900	773	338	186.3	111.5	
RGBA	81000	24000	4940	1822	1056	636	

	0.5m	1m	2m	3m	4m	5m	Diameter (Meters)
30°	0.25	0.50	1.00	1.50	2.00	2.50	(LUX)
R	5660	1824	470	197.1	116	68.7	
G	4500	1202	344	147.1	77.3	50.4	
B	5240	1425	402	177.6	93.9	59.4	
A	2580	667	185	80.6	42.4	25.7	
RGBA	20200	4570	1160	506	268	175.3	

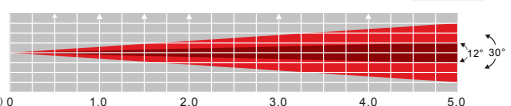

1221500028



1221500029

IKON PROFILE/PEARL

1221500030



1221500031

IKON PROFILE WW/PEARL



Specification

- Bright cold white 32W LED indoor Mini-Profile Spot/Gobo Projector
- High quality optics - Clear powerful output
- 4 DMX Channels
- 5 Dimmer Curves
- Beam Angle: 15-30 degrees
- Manual adjustable Beam Angle and Focus
- Manual Framing Shutters
- Includes 1 textured glass GOBO and 4 metal gobos
- Gobo size: 26,8mm; Viewable size: 24mm
- Drop in GOBO Slot for Metal or Glass Gobos
- Lockable Gel Frame for Color & Color Correction Filters or Frost filter
- Run all night - No Duty Cycle
- Ideal for Mobile DJs, Clubs, Bars, Retail Stores and Promotional Events
- Very low heat output
- Long life LED (Rated at approximately 50,000 hrs.)
- IEC AC outlet on side to daisy chain power (up to 16 Ikon Profile's @ 120V and 27 Ikon Profile's @ 230V)
- Includes scissor yoke to mount on a wall or hang from trussing or set on the ground
- Includes Airstream IR dongle
- Multi-voltage: 100-240V, 50/60Hz
- Power consumption: 44W max
- Dimensions (LxWxH): 408 x 150 x 226mm
- Weight: 6lbs / 2.7 kg.

Specification

- Bright Warm White 32W LED indoor Mini-Profile Spot/Gobo Projector
- High quality optics - Clear powerful output
- 3 DMX Channels
- 5 Dimmer Curves
- Beam Angle: 15-30 degrees
- Adjustable Beam Angle and Focus
- Manual Framing Shutters
- Includes Textured Glass Gobo
- One Glass Gobo Installed, 4 Metal Gobos Included
- Gobo size: 26.8mm; Viewable size: 24mm
- Drop in Gobo Slot for Metal or Glass Gobos
- Lockable Gel Frame for Color & Color Correction Filters or Frost Filter
- Run all night - No Duty Cycle
- Ideal for Mobile DJs, Clubs, Bars, Retail Stores and Promotional Events
- Very low heat output
- Long life LED (Rated at approximately 50,000 hrs.)
- IEC AC outlet on side to daisy chain power (up to 16 Ikon Profile's @ 120V and 27 Ikon Profile's @ 230V)
- Includes scissor yoke to mount on a wall, hang from trussing or set on the ground
- UC IR Remote Control (Sold Separately) & Airstream IR Compatible (Transmitter Included)
- Multi-voltage: 100-240V, 50/60Hz
- Power consumption: 44W max
- Dimensions (LxWxH): 17.75" x 6" x 5" / 408 x 150 x 127mm
- Weight: 6 lbs. / 2.7 kg.



FS600LED

1226300028



IKON IR

1221500027



Specification

- Pro Followspot with a 60W High Powered White LED source
- 8 Colors (White, Red, Blue, Green, Orange, Yellow, 3200K (Warm White) & Purple
- 14° - 26° Beam angle
- Typical Throw: 30 meter (14°) to 40 meter (26°)
- LED Strobe Effect: on board control via slider
- 0-100% dimming: on board control via slider
- Manual focusing
- Manual Iris
- Manual Framing Shutters
- Extruded Aluminum Case design
- 3 and 5 Pin DMX
- Fan Cooled
- Hanging Bracket
- Gel Frame Holder
- Power Consumption: 60W maximum
- Multi-voltage operation: AC 100-240V 50/60Hz (non switchable)

Specification

- Bright white 60W LED indoor Gobo Projector
- Adjustable dimmer and rotate knob on rear panel
- Includes 4 replaceable metal Gobo patterns
- Manual focus
- Color Temperature: 7500K
- Beam Angle: 25, 32 or 43 degrees (Includes 3 different lenses)
- IEC AC outlet on side to daisy chain power (up to 9 Ikon IR's @ 120V and 17 Ikon IR's @ 230V)
- Multi-voltage: 100-240V, 50/60Hz
- Power consumption: 74W max
- Dimensions (LxWxH): 9.5" x 9.5" x 8.5" / 236 x 236 x 215mm
- Weight: 6.6 lbs. / 3 kg.



UC-IR
(Sold Separately)
1321000074



AIRSTREAM IR
1226100319

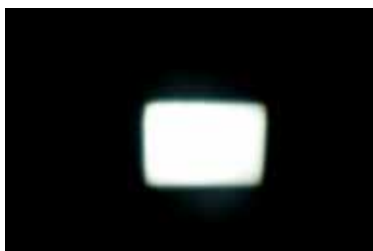

Photometric

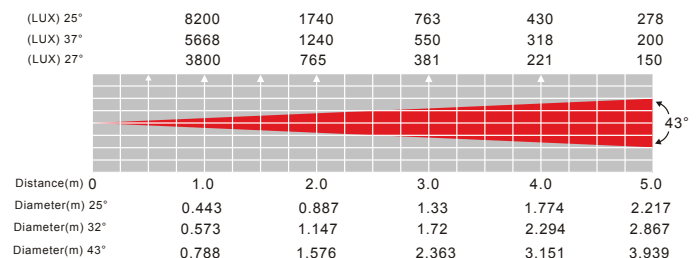



PINPOINT GOBO COLOR

1212200024

PINPOINT GOBO

1212200023



Specification

- 10W RGBA 4-in1 LED Pinspot
- Rechargeable battery powered
- Includes Frost Filter
- 17-33 degree beam
- Includes Power Adapter (DC 8.7V 1A)
- Power Consumption: 11W
- Battery Charge Time: 5 Hours (With POWER switch off)
- Battery Life: 5 Hours (Full On) / 18 Hours (In Energy Saving Mode w/ Full Charge)
- Dimensions (LxWxH): 9.75" x 4" x 2.75" / 245 x 102 x 70mm
- Weight: 3 lbs. / 1.1 kgs.

RGBA Color Mixing:



UC-IR
(Sold Separately)
1321000074



AIRSTREAM IR
1226100319

Specification

- 10W CW LED Pinspot
- Rechargeable battery powered
- Includes Frost Filter
- 17-33 degree beam
- Includes Power Adapter (DC 8.7V 1A)
- Power Consumption: 11W
- 4 Gobos + 5 Color Filters
- Battery Charge Time: 5 Hours (With POWER switch off)
- Battery Life: 4 Hours (Full On) / 12.5 Hours (In Energy Saving Mode w/ Full Charge)
- Dimensions (LxWxH): 9.75" x 4" x 2.75" / 245 x 102 x 70mm
- Weight: 3 lbs. / 1.1 kgs.



UC-IR
(Sold Separately)
1321000074



AIRSTREAM IR
1226100319

Photometric

R	D17	1677	162.7	74.1	39.4	25.7	(LUX)
G	D17	718	192.9	78.9	43.7	28.4	
B	D17	916	205	85.3	53.1	32.8	
A	D17	232	64.8	29.5	15.5	10.2	
RGBA	D17	1770	431	195.4	110.8	68.2	

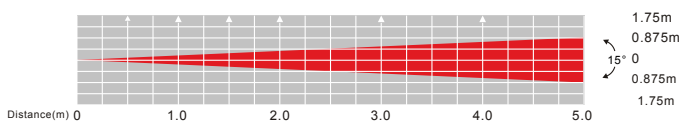

Photometric

CW	D17	3130	876	323	203	127.7	(LUX)
----	-----	------	-----	-----	-----	-------	-------

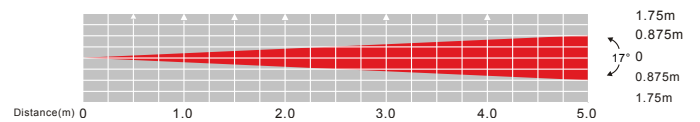

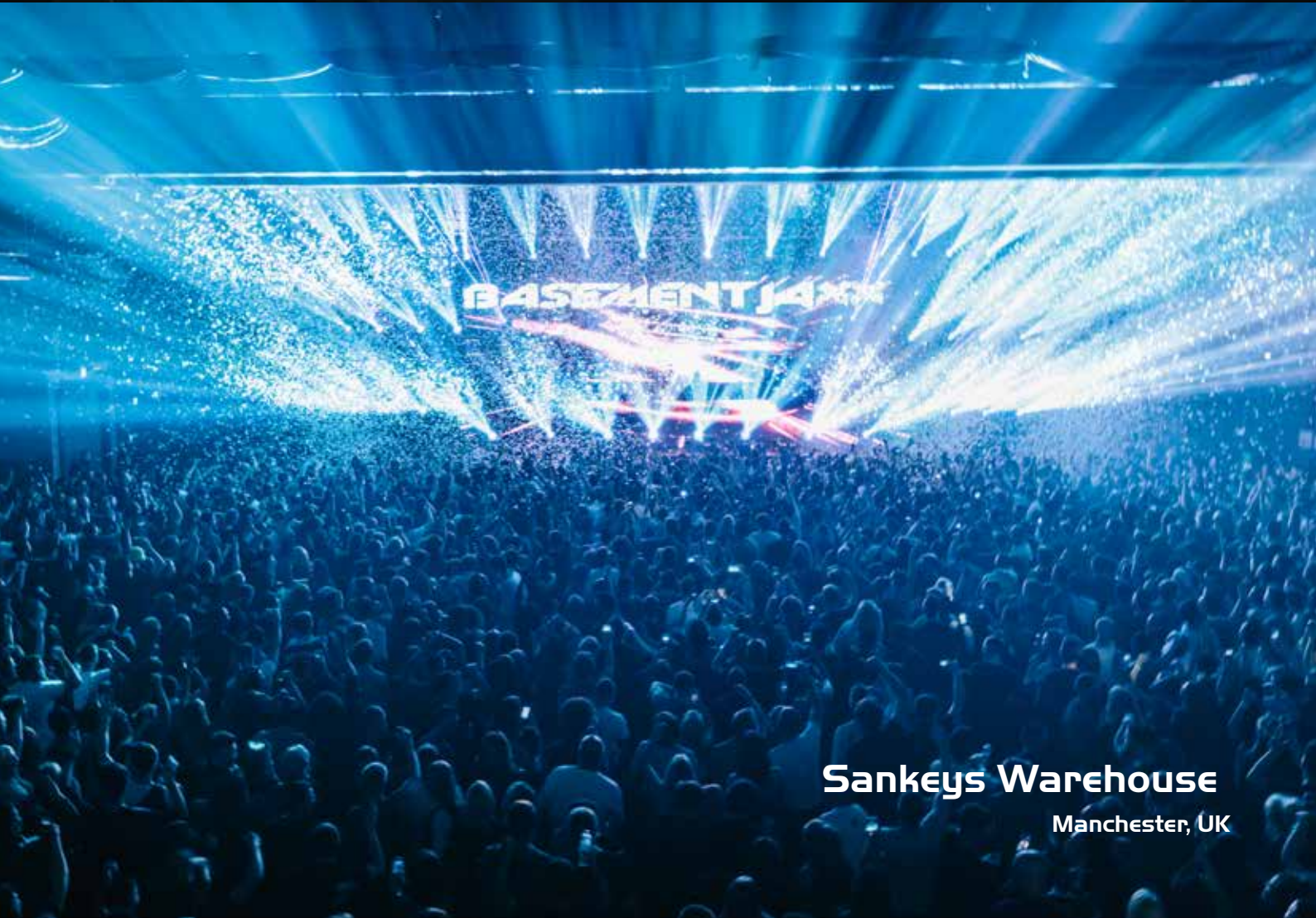

Sankeys Warehouse
Manchester, UK



NEW!

SABER SPOT RGBW

1226100331



NEW!

SABER SPOT WW

1226100330



Features:

- Compact LED Pinspot with ACL lens for a tight, razor sharp beam
- 4-button LED display on rear panel
- Scissor bracket system allows fixture to be hung or set on the ground
- Run all night – No duty cycle
- Smooth RGBW color mixing (fast or slow color change operation)
- Flicker-free operation for film and television
- 9 built-in Color Macros
- Color strobe effect
- Electronic Dimming: 0 - 100%
- Beam angle: 4-degree

Specifications:

- 15-Watt LED (4-in-1) Quad RGBW LED
- 11 DMX Channel modes: 3/4/4/5/6/6/8/8/9/11/12 channel modes includes HSI and HSI+ modes
- 6 Operational modes: Static Color Mode; Color Change Mode; Color Fade Mode; Auto Run Mode; Sound Active Mode and DMX-512 Mode
- Includes additional Beam Fresnel and Wash Fresnel lenses
- Linkable via 3-pin XLR cables (In/Out)
- Power Draw: 14W max
- Long Life LEDs (10,000 hrs.)
- powerCON In/Out
- Multi-voltage operation: 100-240V, 47/63Hz
- Dimensions (LxWxH): 3.5" x 6.75" x 3.5" / 88 x 170 x 87mm
- Weight: 2.6 lbs. /1.2 kgs.

RGBW Color Mixing: 

Features:

- Compact LED Pinspot with ACL lens for a tight, razor sharp beam
- 4-button LED display on rear panel
- Scissor bracket system allows fixture to be hung or set on the ground
- Run all night – No duty cycle
- Flicker-free operation for film and television
- Strobe effect
- Electronic Dimming: 0 - 100%
- Beam angle: 4-degree

Specifications:

- 15-Watt Warm White LED
- 2 DMX Channel modes: 1 or 2 channel modes
- Includes additional Beam Fresnel and Wash Fresnel lenses
- Linkable via 3-pin XLR cables (In/Out)
- Power Draw: 15W max
- Long Life LEDs (10,000 hrs.)
- powerCON In/Out
- Multi-voltage: 100-240V, 47/63Hz
- Dimensions (LxWxH): 3.5" x 6.75" x 3.5" / 88 x 170 x 87mm
- Weight: 2.6 lbs. /1.2 kgs

PINSPOT LED II

1212100001

Specification

- Light Source: Bright 3W white LED Pinspot with 3-degree beam angle
- Compact high-tech plastic case design
- Long-life LEDs: Rated at approximately 50,000 hrs
- Very low heat output and power consumption
- Includes hanging bracket
- 12-degree beam angle lens also included
- Dimensions (LxWxH): 7.25"x4"x2.5" / 184x99x61mm
- Weight: 1 pound / 0.5 kgs.



PINSPOT LED QUAD DMX

12100010

Specification

- 8W Quad (4-in-1) RGBW LED Pinspot (Rated at approximately 10,000 hours)
- Operational Modes: DMX Controlled / Sound Active / IR Remote / Auto Run Programs
- Beam Angle: 15-Degrees
- Lumens: 740 @ 1M at 15°
- DMX Channel: 6 Channel; DMX Connections: 3-Pin DMX In / Out
- Dimming: Adjustable via IR remote; Shutter / Strobe: Adjustable via IR remote
- ADJ UC IR Remote included
- Power Consumption: 11W Max
- Input Voltage: AC 100V-240V 50/60Hz
- Dimensions: 8" x 4" x 2.75" / 205x98x61mm
- Weight: 1 lbs / 0.4kgs



UC IR
(Included)
1321000074



AIRSTREAM IR
1226100319

RGBW Color Mixing: 



PINPOINT GO COLOR

1212100012

Specification

- Rechargeable battery powered, bright 5W RGBA 4-in-1 LED Pinspot with 20-degree beam angle
- Compact high-tech plastic case design
- Long-life LED: 50,000 hour LED life
- Power consumption: 5W & 15W (When Battery Charging)
- Includes magnetic bracket for easy quick install on metal
- X-CLIP Bracket for drop ceiling frame mounting
- Includes Frost Filter
- Rechargeable battery included in fixture
- Includes Power Adapter (DC 12.6V 1A)
- ADJ LED RC2 Remote Control (sold separately)
- Battery Charge Time: 4.5 Hours (With POWER switch off)
- Battery Life: 4.5 Hours (Full On) 6 Hours (In Energy Saving Mode w/ Full Charge)
- Dimensions (LxWxH): 7.25" x 3.5" x 3.75" / 183 x 92 x 95mm
- Weight: 1 lbs. / 0.44 kgs.



RGBA Color Mixing: 



UC-IR
(Sold separately)
132100074



Airstream IR
1226100319



H2O DMX IR

1221500025

UC IR
(Sold Separately)
132100074



Airstream IR
1226100319



H2O IR

1221500023



Specification

- Light Source: 80W LED Source (30,000 hr. rating)
- Simulated water flowing effect
- Equipped with 2 glass effect wheels and 1 independent dichroic color wheel
- 3 operation modes: Show Mode, Manual Mode, & DMX Control
- 3 DMX Channels (Dimming, Glass Wheel, Colors)
- 5 colors + White & Split Colors
- Beam angle: 37 degrees or 27 degrees (optional) / 0-100% Dimming (via DMX) / Manual focusing lens
- ADJ UC IR Compatible (sold separately)
- Power consumption: 70W
- Multi-voltage operation: AC 120-240V 50/60Hz (IEC Plug)
- IEC In & Out to Daisy chain Power (Connect up to 10 Fixtures @ 120V & 17 Fixtures @ 230V)
- Dimensions (LxWxH): 11.75" x 9" x 8" / 301 x 232 x 207mm
- Weight: 9 lbs. / 4 kg.

Specification

- Light Source: Bright 12W LED simulated water flowing effect
- Simulated water flowing effect
- Equipped with 2 glass effect wheels and 1 independent dichroic color wheel
- 5 colors: Orange, Green, Blue, Yellow, Purple + White & Split Colors
- 2 operational modes: seamless scrolling colors or single color operation
- Beam angle: 34 or 43 degrees (optional) / Manual focusing lens
- ADJ UC IR Compatible (sold separately)
- Power consumption: 23.8W
- Switchable voltage: 120V/60Hz or 230V/50Hz (IEC Plug)
- Dimensions (LxWxH): 9.25" x 9" x 7.25" / 236 x 229 x 187mm
- Weight: 7.7 lbs. / 3.5 kg.

Photometric

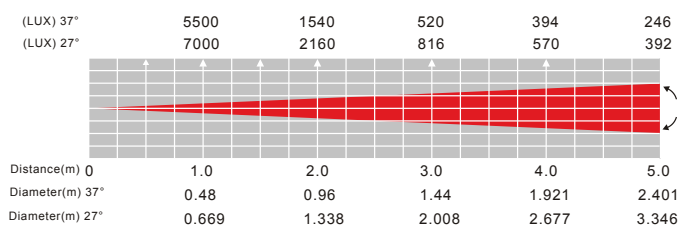

Photometric

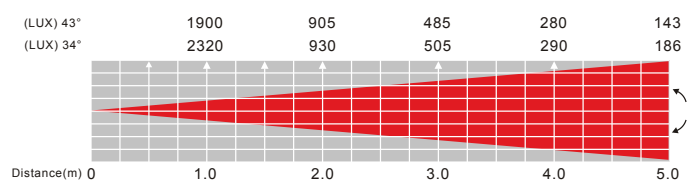

ATMOSPHERIC EFFECTS



ENTOURAGE

1411100019

NEW!

Specification

- Professional grade touring 1500W Faze Machine built into a durable flight case
- 3 DMX Channel Modes; 1/2/4
- LCD Function Display with built-in remote with Fog Timer, Continuous Fogging, & Manual Fogging
- Warm-up time: 45 Seconds
- Output: 15,000 cubic ft./425m³ per min
- External fog fluid tank: 5.6 Liter
- 3-pin & 5-pin DMX In/Out
- PowerCon Input
- Only use high quality, water based fog fluid
- Dimensions (LxWxH): 21" x 15.25" x 9.75" / 533x387x249mm
- Weight: 47 lbs. / 21.3 kg.



ENTOUR VENUE

1411100020

NEW!

Specification

- 1500W mobile DMX Faze Machine
- 3 DMX Channel Modes; 1/2/4
- LCD Function Display with built-in remote with Fog Timer, Continuous Fogging, & Manual Fogging
- Warm-up time: 45 Seconds
- Output: 15,000 cubic ft./425m³ per min
- External fog fluid tank: 5.6 Liter
- 3-pin & 5-pin DMX In/Out
- Hanging bracket
- Only use high quality, water based fog fluid
- Dimensions (LxWxH): 15.5" x 17" x 10" / 394x434x253mm
- Weight: 23 lbs. / 10,6 kg.



FOG FURY 3000

141110008

Specification

- 3 Operational modes: Fog Volume, Fog Duration, & DMX Controlled
- 3 DMX Channel
- 4-button DMX LCD display on rear panel
- ETS "Electronic Thermo Sensing" to always maintain optimum heat.
- Cut off Circuit to protect pump if fog liquid tank runs dry
- Fluid LED color ready tank indicator
- Heater: 1500W / Warm up time (min): 8
- Tank(liter): 5 L / Fog Output: 21000 (cu.ft/min)
- Power Consumption: 1600W (Full On)
- Voltage Operation: AC 120 or 230V, 50/60Hz
- Dimensions (LxWxH):
- 18.75" x 13.75" x 12.75" / 475 x 345 x 321mm
- Weight: 25 lbs. / 11.28 kgs

Compatible Remotes

FF23TR Timer Remote

FF23WR Wireless Remote



FOG FURY 2000

141110007

Specification

- Fluid LED color ready tank indicator
- ETS "Electronic Thermo Sensing" to always maintain optimum heat.
- Cut off Circuit to protect pump if fog liquid tank runs dry
- Heater: 1100W / Warm up time (min): 8
- Tank(liter): 2.5 L / Fog Output: 7000 (cu.ft/min)
- Includes wired remote control
- Power Consumption: 1200W (Full On)
- Voltage Operation: AC 120 or 230V, 50/60Hz
- Dimensions (LxWxH):
- 16.75" x 11.75" x 9" / 421 x 295 x 224mm
- Weight: 16 lbs. / 6.89 kg.
- Only use high quality, water-based fog fluid

Compatible Remotes

FF23TR Timer Remote

FF23WR Wireless Remote



NEW!

FOG FURY 1000 II

1411100023

Specification

- 650W compact, high output Fog Machine
- Visible fog fluid level indicator on rear
- High performance pump for optimum output
- Special heating element design that uses an oil type transmission pipeline system to minimize the possibility clogging
- LED heating indicator system in tank: Red = Heating; Green = Ready to use
- Fog Output: 3500 (cu.ft/min)
- Warm-up time: 4 min.
- Internal fog fluid tank: 0.9 Liter
- Single yoke to mount on a wall or from trussing bracket
- Includes On/Off hardwired remote control with 9ft./3M cable
- Heater: 650W
- Power Consumption: 700W max
- Power: AC 120V/60Hz or 230V/50Hz (non switching)
- Dimensions (LxWxH): 184 x 99 x 61mm
- Weight: 2.95 kg.
- Only use high quality, water-based fog fluid



VF1600

Specification

- 1500W mobile DMX Fog Machine
- High efficiency heater block burns through fog with less residue
- Electronic Thermo Sensing (ETS) for consistent heating
- Fog fluid sensor to protect pump
- Warm-up time: 8 minutes
- Output: 20,000 cubic ft. 566m3/min
- External fog fluid tank: 2.3 Liter
- Includes wired remote (Wireless remote control sold separately)
- Fog output switch on rear panel
- 3-pin DMX In/Out
- Uses water based fog fluid
- Dimensions (LxWxH): 19.5" x 14" x 9" / 495x355x230mm
- Weight: 22 lbs. / 10 kg.

1411100016

Remote Control
(Included)
VFTR Timer Remote



Optional
(Not Included)
VFWR2 Wireless Remote



VF1300

Specification

- 1300W mobile Fog Machine
- High efficiency heater block burns through fog with less residue
- Electronic Thermo Sensing (ETS) for consistent heating
- Fog fluid sensor to protect pump
- Warm-up time: 7 minutes
- Output: 12,000 cubic ft. 340m3/min
- External fog fluid tank: 2.3 Liter
- Fog output switch on rear panel
- Uses water based fog fluid
- Dimensions (LxWxH): 17.5" x 12.5" x 8" / 445x315x200mm
- Weight: 15 lbs. / 7 lbs.

1411100015

Remote Control
(Included)
VF5PR Timer Remote



Optional
(Not Included) Optional
(Not Included)
VFWR2 Wireless Remote VFTR13 Timer Remote



NEW!

VF1100

Specification

- 1000W mobile Fog Machine
- High efficiency heater block burns through fog with less residue
- Electronic Thermo Sensing (ETS) for optimum heating levels
- Low fog fluid shut off sensor to protect pump
- Warm-up time: 6 minutes
- Output: 9,000 cubic ft. per min
- Internal fog fluid tank: 1 Liter
- Fluid level indicator
- Includes ADJ VF5PR wired remote
- ADJ VFWR Wireless remote control is included
- Fog output switch on rear panel
- Only use high quality, water-based fog fluid
- Dimensions (LxWxH): 13.75" x 9.5" x 10" / 350 x 240 x 250mm
- Weight: 8 lbs. / 3.64 kg. Specifications subject to change without notice- Power: AC 120V/60Hz or 230V/50Hz (non switching)
- Dimensions (LxWxH): 7.25" x 4" x 2.5" / 184 x 99 x 61mm
- Weight: 7 lbs. / 2.95 kg.

1411100024

Remote Control
(Included)
VF5PR Timer Remote



Remote Control
(Included)
VFWR Wireless Remote



VF400

Specification

- 400W mobile Fog Machine
- High efficiency heater block burns through fog with less residue
- Warm-up time: 3 minutes
- Output: 3,000 cubic ft. 85m3/min
- Internal fog fluid tank: .5 Liter
- Fluid level indicator
- Includes wired remote
- Uses water based fog fluid
- Dimensions (LxWxH): 9.5" x 8" x 5.5" / 240x200x140mm
- Weight: 4 lbs. / 2 kg.

1411100013

Remote Control (Included)
VF400R Timer Remote



Remote Control (Included)
FFJWR Wireless Remote



NEW!
FOG FURY JETT PRO

1411100021



The ADJ Fog Fury Jett Pro is a high velocity vertical Fog Machine that mixes color into the fog from 28x 3-Watt LEDs (6 Red, 7 Green, 6 Blue, 3 Amber & 6 UV LEDs). The Fog Fury Jett Pro produces a dry even blast of fog over 40 feet (12 meters) in the air. It has a special heating element design that uses an oil type transmission throughout the pipeline to prevent clogging. It is also equipped with a high performance Italian pump system for optimum output. ADJ's Electronic Thermo Sensing (ETS) technology is on-board to maintain optimum heat levels with short warm-up time between fog blasts.

The Fog Fury Jett Pro may be use vertically or horizontally. The reservoir tank may be mounted in the front or rear of the unit so the machine may be pointed up or down. Control options included 3-pin and 5-pin DMX In/Out connections, ADJ's WiFLY EXR wireless DMX on-board, plus the ADJ FFJWR wireless remote comes included in the box.

Specification

- LED and/or FOG effect combination
- Operates in multiple positions
- On Board control or remote control
- WiFLY EXR Wireless DMX (up to 2,500 ft. /760M line of sight)
- ADJ's Electronic Thermo Sensing (ETS) technology
- Safety cable eye bolt

Technical Information:

- Optical: 28 x 3-Watt LEDs (6 Red, 7 Green, 6 Blue, 3 Amber & 6 UV LEDs)

Output:

- Output: 40,000 Cubic Feet/1.132m3 Per minute
- Heater: 1450 Watts
- Heat Up Time: 9 min
- Fluid Type: Water Based Fog Fluid, ADJ Fog Juice CO2
- Fluid Consumption: 150ml/min
- On board control or Wireless DMX

Connections:

- Data: 3-pin & 5-pin DMX In/Out

Control:

- DMX Channels: 1, 2, 3, 7 or 9 DMX channels
- Integrated WiFLY EXR Wireless DMX
- Remote Control Included: FFJWR
- On Board Control: Yes

Electrical:

- AC 120V/60Hz or 240/50Hz (non switching)

Physical:

- Dimensions (LxWxH): 16.5" x 12.5" x 8" / 419 x 315 x 206mm
- Weight: 21lbs. / 9.5 kg
- Tank Size: 2.5 Liter removable tank



FOG FURY JETT

1411100017

Specification

- 680W professional DMX colour Fog Machine / Warm-up time: 9 min
- ADJ's Electronic Thermo Sensing (ETS) technology
- Automatic circuit cut-off to protect pump if fog fluid tank runs dry
- Special heating element design that uses an oil type transmission pipeline system to minimize the possibility clogging
- 3 Operational modes: Manual, Remote Control, or DMX Controlled / 4 DMX Channels
- External fog fluid tank: 3 Liter / Fog Output: 20,000 (cu.ft 566m3/min)
- Tank can be mounted to either front or rear
- Included Accessory: ADJ FF23TC - wireless remote
- Power Connection: IEC AC In
- Light Source: 12 x 3w RGBA LED's, (3 Red, 3 Green, 3 Blue & 3 Amber LED's)
- Voltage: AC 120V, 230 or 240 50/60Hz (non switching)
- Dimensions (LxWxH): 15.5" x 12" x 7.5" / 397 x 302 x 191mm
- Weight: 16 lbs. / 7.1 kg.

Remote Control (Included)
FFJWR Wireless Remote



VF VOLCANO

1411100018

Specification

- 750W professional vertical Fog Machine with 6 x 3-Watt LEDs
- ADJ's Electronic Thermo Sensing (ETS) technology
- High performance pump for optimum output
- Special heating element design that uses an oil type transmission pipeline system to minimize the possibility clogging
- 2 Operational modes: Manual & Remote Control
- Warm-up time: 6 min
- External fog fluid tank: 1 Liter/Fog Output: 8,000 (cu.ft 226m3/min)
- Only use high quality, water-based fog fluid
- Included Accessory: VFV-WR wireless remote
- Power Consumption: 770W
- Light Source: 6 x 3-Watt LEDs, (2 Red, 2 Green, & 2 Blue LEDs)
- Voltage: AC 120V or 240 50/60Hz (non switching)
- Dimensions (LxWxH): 13" x 8.25" x 7" / 327 x 212 x 177mm
- Weight: 7.4 lbs. / 3.36 kg.

Remote Control (Included)
VFV-WR Wireless Remote

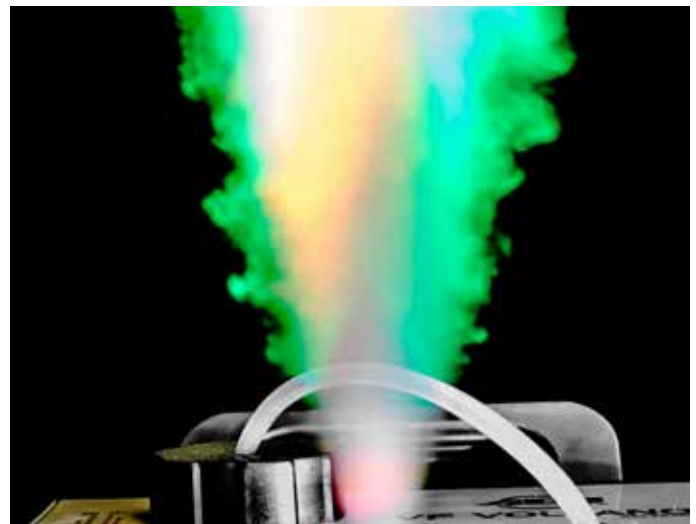

MISTER KOOL II

1411100025

NEW!

- Specification
- Low-lying fog stays low to the ground similar to a dry ice effect
- Uses standard fog juice and ice cubes
- No need for expensive fog chillers, bulky air conditioning units or dry ice
- Includes non-removable timer remote with On/off switch
- Perfect for Halloween and theatrical events
- Load up to 2 kg of ice in the chiller box
- Water drainage valve system allows for easy cleanup. Water drains directly into the provided plastic bag.
- Heater: 400W
- Fog fluid container: 1/2 liter (external)
- Dimensions (LxWxH): 490 x 315 x 260 mm
- Weight: 8kg



VF SNOW FLURRY HO

1223100003

Specification

- 1250W mobile DMX Snow Machine
- Spray distance: 8-10 meters
- Volume selection switch: Low or high snow output
- Low snow fluid sensor to protect pump
- Internal snow fluid tank: 2.3 Liter
- Fluid level indicator
- Includes wired remote
- ADJ UC IR Compatible (Sold Separately)
- On/Off switch on rear panel
- 3-pin DMX In/Out
- Uses water based snow fluid
- Dimensions (LxWxH): 20" x 12.5" x 13.75" / 510 x 316 x 349mm (With Bracket)
- 20" x 12.5" x 10.5" / 510 x 316 x 268mm (Without Bracket)
- Weight: 18 lbs. / 8 k

Remote Control (Included)
VFFR Timer Remote



VF FLURRY

1223100002

Specification

- 600W mobile Snow Machine
- Spray distance: 2-5 meters
- Volume selection switch: Low or high snow output
- Snow fluid sensor to protect pump
- Internal fog fluid tank: 1 Liter
- Fluid level indicator
- Includes wired remote
- On/Off switch on rear panel
- Uses water based snow fluid
- Dimensions (LxWxH): 13.5" x 10" x 8" / 340x255x200mm
- Weight: 8 lbs. / 3.8 kg.

Remote Control (Included)
VFFR Timer Remote



BUBBLETRON

1212100006

Specification

- Portable high output bubble machine - creates hundreds of bubbles per minute
- Large high velocity fan makes bubbles rise quickly in the air
- ON/OFF switch on rear of unit and ON/OFF wired remote with 25 ft./8M cable
- Most types of bubble liquid acceptable
- Power Consumption: 24W
- Capacity of bubble juice: 1 Liter
- Fluid Consumption Rate: 1 Liter every two hours
- Multi-voltage: AC120-230V, 50/60Hz
- Dimensions (LxWxH): 14"x7"x8.25" / 352x176x209mm
- Weight: 4 lbs. / 2kg.



BUBBLETRON GO

12121000014

Specification

- Portable high output bubble machine
- Durable plastic casing with EZ-Access front fluid tank
- Large high velocity fan makes bubbles rise quickly in the air
- ON/OFF switch on rear of unit
- ON/OFF wired remote with 25 ft./8M cable
- Power Consumption: 24W (120V) / 10W (230V)
- Fluid Consumption Rate: 1 Liter every 50 Mins. (120V) / 1 Liter every 90 Mins. (230V)
- Multi-voltage: AC120-230V, 50/60Hz
- Dimensions (LxWxH): 13.75" x 7" x 8.25" / 352 x 176 x 209mm
- Weight: 4 lbs. / 2kg.



BUBBLETRON XL

1212100006

Specification

- Portable high output bubble machine - creates hundreds of bubbles per minute
- Extra-large, durable plastic casing with EZ- Access front fluid tank
- Large dual high velocity fans makes bubbles rise quickly in the air
- ON/OFF switch on rear of unit
- Carrying handle
- Most types of bubble liquid acceptable
- Power Consumption: 37W @ 120V / 14W @ 230V
- Tank Capacity: 2 Liter
- Fluid Consumption Rate: 40ml/per minute
- Voltage: AC120/60Hz or 230V/60Hz
- Dimensions (LxWxH): 359x266x278mm
- Weight: 9lbs. / 3.7kgs.
- Includes 9-foot / 3M On/Off Wired Remote Control



NEW!



FF23TR

1221000008

Specification

- Timer Remote
- Duration Control
- Interval Control
- Power On/Off Switch
- DMX 3-pin XLR input
- Manual/DMX control (dipswitch addressing)
- Manual Fogging

Compatible With:

- Fog Fury 2000 (optional)
- Fog Fury 3000 (included)
- Fog Fury 3000 WIFLY (included)
- Fog Fury Faze (optional)



VF5PR

9900006271

Specification

- Manual Fogging

Included With:

- VF1300
- VF1000



FF23WR

1411100012

Specification

- Wireless Remote
- Power On/Off Button
- Manual Fogging Button

Compatible With:

- Fog Fury 2000 (optional)
- Fog Fury 3000 (optional)
- Fog Fury 3000 WIFLY (optional)
- Fog Fury Faze (optional)



VFTR1B

1223200037

Specification

- Timer Remote
- Interval Control
- Duration Control
- Timer On/Off Button
- Continuous Fog
- Manual Fogging

Compatible with:

- VF1300 (optional)
- VF1000 (optional)



FFFTR

9900006111

Specification

- Timer Remote
- Duration Control
- Interval Control
- Timer On/Off Button
- Continuous Fogging
- Manual Fogging

Included With:

- Fog Fury Faze



VFWR

9900006330

Specification

- Wireless Remote
- Controls up to 4 fog Machines
- 4 Assignable Buttons

Included With:

- VF1000



VFTR

9900006329

Specification

- Timer Remote
- Duration Control
- Interval Control
- Output Level Control
- Timer On/Off Switch
- Continuous Fog
- Manual Fogging

Included With:

- VF1600



VFFR

9900006328

Specification

- Timer Remote
- Output Volume Control
- In Use indicator
- Low Liquid Indicator
- On/Off Fogging Switch

Included With:

- VF Flurry



VFWR2

9900006327

Specification

- Wireless Remote
- Controls upto 4 Fog Machines
- 4 Assignable buttons

Included With:

- VF1600
- VF1300



FFJWR

9900006545

Specification

- Wireless Remote

Included With:

- Fog Fury Jett
- Fog Fury Jett Pro



Fluid for fog machines to create long lasting smoke and fog effects. To use in professional applications like shows, concerts, clubs or theaters.

Fog Juice 1 light



Fog Juice 1 light: made for making laser and light shows visible

1 Liter	1421200023
5 Liter	1421200006
20 Liter	1421200009

Fog Juice CO2

5 Liter 1421200022



Fluid for fog machines to create long lasting smoke and fog effects. To use in professional applications like shows, concerts, clubs or theaters.

Fog Juice CO2: Very short lasting CO2 effect fluid. Perfect for use with Fog Fury Jett and Fog Fury Jett Pro

Fog Juice 2 medium



Fog Juice 2 medium: standard fog juice for clubs & disco recommended also for use in Fog Fury Faze, Entourage & Entour Venue Fazer

1 Liter	1421200024
5 Liter	1421200007
20 Liter	1421200010

Bubble Juice

ready mixed

5 Liter 1422200001



Ready to use 5 litre Bubble Juice.

Fog Juice 3 heavy



Fog Juice 3 heavy: long lasting effective smoke effects

1 Liter	1421200025
5 Liter	1421200008
20 Liter	1421200011

Cleaning Fluid



250 ml
1221200004

- Cleaning fluid for regular fog machines
- 250ml = enough for 5 full cleanings
- Cleans your fog machine from fluid residues
- Extends the life time of your fog machine enormous
- Gives you again a full blast of fog when heater was dirty
- It's recommended to clean machines after every 30h usage
- Acid! Keep away from children, eyes and skin

Snow Juice

5 Liter 1223200004



SNOW FLUID, for Audio Visual Effects Units

- 5 Liter high quality snow fluid
- Produced foam flakes
- Odorless

FOG SCENT

- 1211200003 Cherry
- 1211200004 Banana
- 1211200005 Mint
- 1211200006 Tutti Frutti
- 1211200007 Apple
- 1211200008 Cocos
- 1211200009 Vanilla
- 1211200010 Lemon

- Used for creating smell in artificial smoke liquid which are used in application such as shows or professional training
- Composition: is a mix of mineral oil, undecylhypolyoxyethylen, various ethoxyl alcohol, methyl, different essences and osmoted water
- It is neither an eye nor a skin irritant
- Comes in different fragrances
- Size: 20 ml



BUBBLE PERFUME

- 1212200017 Red Energy
- 1212200018 Tutti Frutti
- 1212200019 Coffee
- 1212200016 Gala Champagne

- Works with all bubble fluids
- For Use with Bubble machines
- Comes in different fragrances
- Size: 20ml



mirrorballmotor

1U/min (50cm/10kg)

1221200003



- Heavy-duty 1 R.P.M. Mirror Ball Motor
- For use with up to a 20-inch (50cm) mirror ball
- Rotation speed: 0.8-1 R.P.M.
- Indoor Use Only
- Max load: 22 lbs. /10kg.
- Power:AC 120V/60Hz or 230V/50Hz (non switchable)
- Dimensions (LxWxH):5.5" x 5.5" x 3.25" / 136x136x80mm
- Weight: 2.5 lbs. / 1.055 kg

mirrorballmotor

1,5U/min (100cm/40kg)

1221200001



- Heavy-duty professional mirror ball motor
- For use with up to a 40-inch (1m) mirror ball
- Easy-to-use: plug and play
- Rotation speed: 1 - 1.5 R.P.M.
- Indoor Use Only
- Max load: 89 lbs. / 40kgs.
- Power: AC 120V/60Hz
- Dimensions (LxWxH): 11.25" x 9.5" x 4.5" / 280 x 240 x 110mm
- Weight: 6 lbs. / 2.5 kgs.

mirrorballmotor

1,5U/min (40cm/4kg)

1221200002



Mirrorball motor for using with max. 40 cm Ball. 1,5U/min. Security motor.

mirrorballmotor

(20cm/3kg)

1211200001



Mirrorball motor for using with max. 20 cm Ball. 1,5 rpm.

1211200002

Mirrorball motor for using with max. 20 cm Ball. 2,5 rpm.

MBS-300

1221100009



Party Set Mirrorball includes:

- 1 x mirrorball 30cm
- 1 x pin spot black
- 1 x lamp for pin spot 6V/30W
- 1 x mirror ball motor
- 4 color caps (red, green, blue, yellow)



Mirrorballs



- Mirrorball with solid plastic core
- High stability through continuous axis
- Continuous bonding
- Real glass mirrors
- Holding bail
- Additional security bail for security chain safety
- Motor not included

1211100001	5cm
1211100002	10cm
1211100003	20cm
1211100004	30cm
1221100005	40cm
1221100006	50cm
1221100007	1m

LTS-6

This low cost, Black tripod stand is ideal for hanging several types of par cans or pin spots. It's also great for mounting lighting fixture on top of the tripod (such as: Follow Spots, lighting effects, par can etc.)

Specification

- Extends up to 9ft/270cm.
- LTS-6 comes with T-bar with 8 hanging point bolts
- Max evenly distributed load : 25kg
- LTS-6 comes with T-bar with 4 hanging point bolts
- Includes FS-Adapter - designed to mount one light at a time at the top of the stand
- Weight: 11 lbs. / 4.9 kg

1731000006

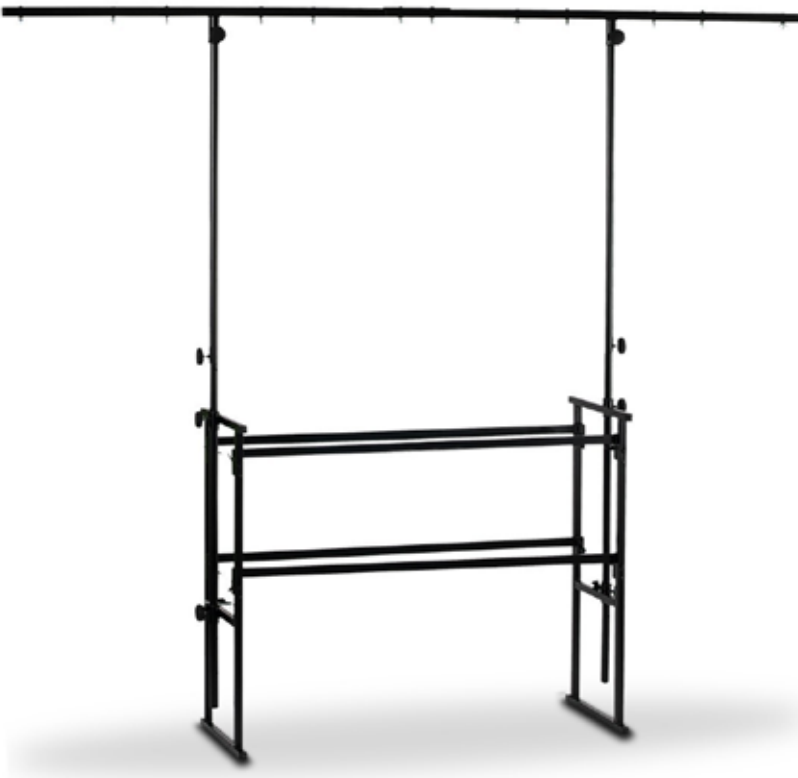

DJ-MTS 4

1739000002

Fabulous DJ Stand with highest flexibility and a very stable stand. It's total weight is just 17kg so it's easy to be carried around to all set ups. The DJ just needs 5-8 min to build up the complete system. The 2 integrated lighting stands with t-bars can be removed if not needed.

Specification

- Height of the first table rails: 57cm
- Height of the second table rail: 93cm
- Width of the complete stand system (without T-Bars): 126cm
- Depth of the system: 38cm
- Min. height of T-Bars: 211cm
- Max height of T-Bars: 251cm
- The 2 T-bars can be connected with screws: max width: 260cm
- Distance from one rail to the next: 32cm
- Adjustable feet
- Max vertical load for T-Bars: 30kg

DJ-MTS 4 Bag

- Bag for DJ-MTS 4 stand.

1739000003



LSS 4S, speaker stand steel, black

1163900011

Sturdy steel speaker stand tripod

Specification

- 35 mm mast diameter
- With safety bold
- Maximum height: 209 cm
- Minimum height: 108 cm
- Color: black
- Max load: 30kg



LSS-3S, PRO-speaker stand steel, black

1163900003

Professional loudspeaker stand

Specification

- Very stable metal construction
- With safety bold
- 35 mm mast diameter
- With safety bold
- Maximum height: 2m
- Minimum height with safety bold: 1,46m
- Minimum height w/o safety bold: 1,22m
- Color: black
- Max load: 40kg



SWB40 - wall mount speaker bracket 40kg

1163900003



- Maximum load: 40kg
- Length: 31cm
- Max pivoting radius: 180°
- Base plate: 20 x 15 cm
- Weight: 2,1kg

Tripod Cover

1724400045

- The Tripod Cover offers the opportunity to grade up your speaker stand on special occasions like weddings, galas and company events. Place your led-effect behind the Tripod Cover and your speaker stand will become an eye-catcher.
- The cover can be washed at 30° one time and should be impregnated with a fire retardant liquid after the second wash.



SB-2 Bag for 2 stands

1154000014

- SB-2 Bag for 2 speaker stands
- Dimensions : 1240x220x220cm



Microphone stand high ECO-MSI

1753900004

Specification

- Professional stand also for "On Tour" usage
- All couplers are from metal
- Removable top section
- Up to 2,22m high
- Transport size: 94cm
- Incl. reduction thread and cable clips
- Length of legs: 32cm
- Length of boom arm
- Max. height incl. boom arm: 2,3m



Microstand PRO-MSI tripod, extend. Boom

1753900001

Specification

- Professional steel stand
- Retractable legs
- Noise reduction rubber feet
- Length of legs: 31cm
- Length of boom arm: 80cm
- Max height incl. boom arm: 2,10 Meter
- Solid manufacture for stage use
- Extension with easy-screw mechanics
- Incl. cable clip



Microstand PRO-MS2 cast-iron base

1753900002

Specification

- Black microphone stand
- Special rubber coating for noise reduction on base
- Diameter base: 25cm
- Screw thread 3/8 inch
- Max height: 1,60m
- Solid manufacture for stage use
- Extension with easy-screw system
- Incl. cable clip



Microphone stand small ECO-MS3

1753900005

Specification

- A low microphone stand for bass drums, guitar amps etc.
- Adjustable height and shock absorbent rubber feet.
- Noise reduction, rubber feet
- Length of legs: 25cm
- Max. height: 0,76cm
- Dual extension
- Length of boom arm (twice extended): 70cm



MB-I Bag for micro stand

1154000017

- Useful bag for everybody who has to transport one microphone stand.
- Inner dimensions : (L x W x H): 1010 x 110 x 80mm



MCI Microphone holder, clamp, black

Code: 1154000012



MC2 Microphone holder, rubber, black

Code: 1154000013



MC3 Microphone holder, rubberized

Code: 1154000015



MC4 Microphone holder, mini

Code: 1154000043



OSLIM 2

1741000057

The ADJ O Slim 2 Clamp is designed to fit in-between the "V" shaped truss braces where larger size clamps will not fit. It can also be used like a traditional ADJ O-Clamp to hang smaller fixtures under 28 lb/13 kg. The O Slim 2, like the ADJ O-Clamp, wraps around the entire 2-inch truss pipe to avoid scuffing, scratching and denting of truss.



MINI O-CLAMP

1741000058

Mini O-Clamp: Fits 3/4 inch - 19 mm Truss. 360° wrap around tube truss clamp. Securely mounts fixtures to the truss braces (Non scuffing - Non scratching - Non scoring - Non denting)



BABY CLAMP

silver 1741000008

Baby Clamp: Ideal for fixtures under 10 lbs./5 kg i.e. pinspots & Par-38 Cans

black 1741000046



Light Bridge Clamp

1741000015

Mini truss clamp for Light Bridge One. Max. load 20 kg



BOX-2 adapter for lights&bars, M8

1163200002

Specification

- Stand adapter with M8 screw
- Inner diameter 35mm
- Durable steel, black coated
- Diameter of dish: 9cm
- Great to mount light effects and PARs on stands
- Suitable for all stands with 35mm tube

Floor Stand

FS4LB black

1226100032



To turn your PAR can into a floor PAR simply open the floor bracket and fix it to the existing bracket of the PAR can.

Specifications:

- Rubber feet
- M10 screw included
- Feet length: 23 cm (total)
- Height: 3 cm
- Max load: 15 kg

SAFETY CABLES

L 30 cm
Ø 2 mm

1744000003 5 kg

L 80 cm
Ø 2 mm

1744000002 5 kg

L 140 cm
Ø 3.2 mm

1744000001 5 kg



L 60 cm
Ø 3 mm

1744000004 10 kg

L 60 cm
Ø 4 mm

1744000005 30 kg

L 60 cm
Ø 5 mm

1744000006 45 kg

L 60 cm
Ø 6 mm

1744000007 60 kg

L 60 cm
Ø 8 mm

1744000008 100 kg



To use safeties is law in most locations.

TRUSS ADAPTER

1732000003

Truss Adapter for 35mm Stands

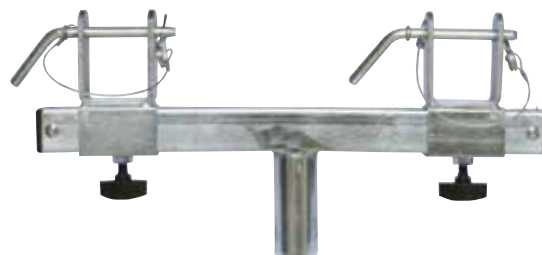

TV ADAPTER

1731000011

TV Adapter for 35mm Stands



TV-SPIGOT

1741000014

Spigot (TV-plug) for standard stands 28 mm with M10 screw



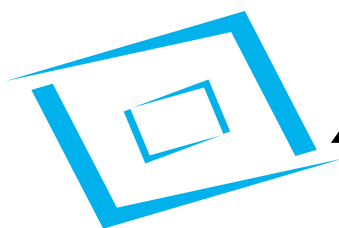

ACCU-CASE™

PLAY IT SAFE...



ACF-TOUR CASE INNO 4 1521000184

The Case offers maximum protection for 4 Inno Color Beam Series moving heads

Specifications:

- Solid 7 mm thick plywood
- Strong aluminium profiles
- Heavy duty handles
- Steel ball corners
- 4 wheels
- Butterflylocks
- Color: black

KG	L 732 mm
28.5	W 443 mm
	H 585 mm



ACF LED BAR CASE 4 1521000186

The LED BAR Case offers maximum protection for 4 LED Bars (Elar Ex Tribar, Mega Tri Bar, Mega Bar LED RC, Sweeper Beam LED, Sweeper Beam QUAD LED)

Specification

- Solid 7 mm thick plywood
- Max length of the LED BAR: 115 cm
- Strong aluminium profiles
- Heavy duty handles
- Steel ball corners
- Butterflylocks
- Color: black

KG	L 1240 mm
21.1	W 621 mm
	H 251 mm



ADJ TOURING CASES

ADJ Touring Case 2x Vizi Beam SRX

Code: 1521000253

Touring Case 2x Illusion Dotz 4.4/3.3

Code: 1521000251

ADJ Touring Case 2x Vizi Hybrid I6RX

Code: 1521000285

ADJ Touring Case 2x Vizi BSW 300

ADJ Touring Case 4x Vizi Hex/QWash7

ADJ Touring Case 4x Focus Spot Three Z

Code: 1521000284

ADJ Touring Case 4x Inno Color Beam ZI9

Code: 1521000221

ADJ Touring Case 4x Vizi Beam RXONE

Code: 1521000283

ADJ Touring Case 6x 7PZ IP

ADJ Touring Case 8xAV6X

Code: 15210000306

ADJ Touring Case 8x AV3

Code: 15210000305



ADJ TOURING CASE 6X LED PAR UNIVERSAL

Universal Touring case for 6 PARs. Bluewheels sold separately
Compartment dimensions (WxLxH) : 200mm x 260mm x 300mm

1521000254

Compatible with :

- WiFly QAS IP
- WiFly EXR QA5 IP
- WiFly EXR HEX5 IP
- Lightning COB Cannon
- UV COB Cannon
- Dotz PAR100
- WiFly EXR Dotz PAR (without Snoot)



ACF-SW/SCENESETTER 24 CASE

1521000071

Protect your controller and transport it only with case.

Specification

- Solid 7 mm thick plywood
- Strong aluminium profiles

KG	L	371 mm
	W	504 mm
	H	123 mm
5.2		



ACF-SW/DMX OPERATOR

1521000070

This durable roadcase is specially made for lighting controllers. It has aluminium profiles and ball corners to protect the unit. It fits f.e. DMX OPERATOR I , DMX Operator 384 & Wifly WLC-16

Specification

- Solid 9 mm plywood
- Butterflylocks
- Color: black

KG	L	240 mm
	W	504 mm
	H	118 mm
3.8		



ACF-SW/VMS ROAD

1521000127

The VMS Road-Case is designed to protect the AMERICAN AUDIO VMS4.1 and VMS5 and VMS4.1. It offers an additional Laptop board as well as front and rear openings for easy cabling and access to the VMS's front controls.

Specification

- Heavy duty roadcase for VMS Series Midi-consoles
- Removable lid
- Laptop board
- Aluminium profile
- Foam coverage to protect the unit from scratches
- Metal ball corners
- Heavy handle
- Butterfly lock
- Rear opening for cabling
- Front opening to access the control knobs of the VMS
- Good air circulation

KG	L	564 mm
	W	425 mm
	H	245 mm
10.8		



Equipment sold separately.

ACF-SW/DDR

Professional Doubledoor-rack for audio and light equipment.

Specification

- 7 mm strong wood
- Ball corners
- Butterfly latches (DDR4)
- Handles for transport
- Rubber feet
- Rails & Screws included - Mounting Depth: 44,3cm



1521000006

ACF-SW / DDR2



1521000007

ACF-SW / DDR3



1521000010

ACF-SW / DDR4



ACF-PW/ROAD CASE

Professional road case to protect your equipment and tools.
The ROAD CASE series is made from extra strong 9mm plywood.
Different sizes available.

Specification

- Foam coverage inside to protect equipment
- Solid 9mm plywood
- Strong aluminum profile
- Steel ball corners
- Strong handles on 2 sides
- Rubber feet

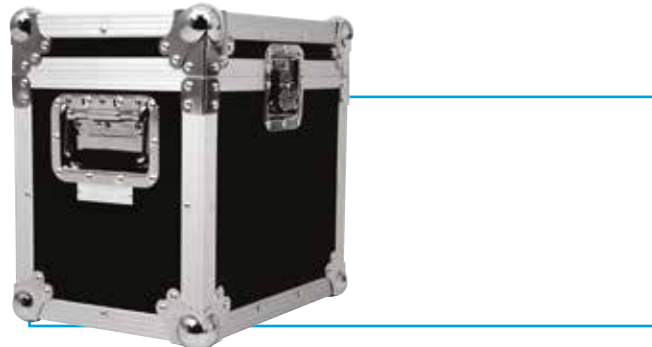

1531000012

ACF-PW / Road Case S: inner dimensions: 360 x 360 x 260 mm



1531000013

ACF-PW / Road Case M: inner dimensions: 550 x 350 x 390 mm

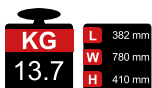

1531000014

ACF-PW / Road Case L: inner dimensions: 750 x 350 x 390 mm



ACF-SA/TRANSPORT CASE

The aluminium transport cases from Accu Case are the perfect solution for all your transport needs when on the road. They offer safe transport and cover your equipment from dust and damage. There's a carrying handle on both sides.

Specification

- Aluminium case
- Color: Aluminium
- Available sizes: S, M, L, XL, XXL



KG	L	317 mm
3.6	W	459 mm
	H	263 mm

1522000002 ACF-SA/Transport Case S



KG	L	376 mm
3.7	W	569 mm
	H	363 mm

1522000003 ACF-SA/Transport Case M



KG	L	377 mm
3.9	W	570 mm
	H	369 mm

1522000004 ACF-SA/Transport Case L



KG	L	385 mm
3.5	W	585 mm
	H	270 mm

1522000005 ACF-SA/Transport Case XL



KG	L	455 mm
4.7	W	690 mm
	H	317 mm

1522000006 ACF-SA/Transport Case XXL

ACF-SW/AC ACCESSORY CASE

Heavy Duty Accessory Case with foam inlay

Specification

- 2 catches and 1 Handle
- Steel Ball corners and aluminium profiles
- Top is completely foamed
- 3 layers of pre-cut foam (1 x 1 cm) to peel off included
- Dimensions inside: Length 560mm x Width 280mm x Height (w/o top) 100mm

Set of extra 3 foam inlays optional available



152100014

Equipment sold separately.

ACM/FOAM INLAY AC-OI

ACCESSORYCASE (3PC)
L 560 X W 280 X H 100

3pc = 1 Set
pre-cut



155400001

ACF-SW/AC MINI ACCESSORY CASE

The Mini Accessory Flight case from Accu Case enables you to transport all the little stuff that normally gets lost during being on the road. It offers safe transport, protects your materials from dust and damage. There's a carrying handle on the front.

Specification

- Strong aluminium profiles
- Foam coverage inside to protect equipment
- Color: silver



1521000103

ACF-SW/AC M ACCESSORY CASE

The AC M Accessory flight case from Accu Case is a universal toolcase for divers accessories. It offers safe transport, covers your equipment from dust and damage. The inside is completely filled with pre-cut foam, which enables you to make perfect fittings for your stuff. There's a carrying handle on the front and 2 lockable locks.

Specification

- Solid 7 mm thick plywood
- Strong aluminium profiles
- Steel ball corners
- Foam coverage inside to protect equipment
- Rubber feet
- Color: black



1521000107

ACF-SW/AC XXL ACCESSORY CASE

1521000046

The AC XXL Accessory flight case from Accu Case is a universal toolcase for divers accessories. It offers safe transport, covers your equipment from dust and damage. The inside is completely filled with pre-cut foam, which enables you to make perfect fittings for your stuff. There's a carrying handle on the front and 2 butterfly locks.

Specification

- Solid 7 mm thick plywood
- Strong aluminium profile
- Steel ball corners
- Foam coverage inside to protect equipment
- Rubber feet
- Color: black
- Inner dimensions: L578 x W 480 x H 207 mm

KG	L	637 mm
4.5	W	590 mm
	H	260 mm



ACF-SW/PROTEK TT PRO CASE BLACK

1521000022

Specification

- Heavy duty turntable hardcase with sturdy brackets and ball corners
- Fits one American Audio or other popular turntable brands
- Black surface
- Sturdy aluminum frame
- Foam inlay
- Transport handles
- Removable lid
- Butterfly locks
- Equipment not included

KG	L	420 mm
7.2	W	528 mm
	H	230 mm

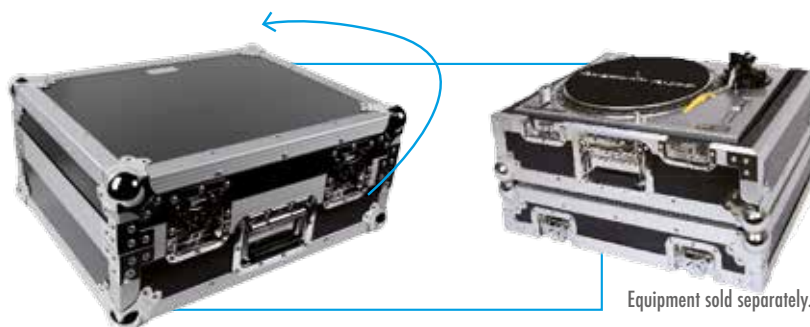

Equipment sold separately.

ACF-SW/MICROPHONE CASE

1521000023

This microphone road case is made for 12 dynamic microphones and accessories. Protect your equipment during transport and storage. The case is fitted with foam and has a butterfly lock. A handle is on top of the case. The case is available in metallic black aluminium finish.

KG	L	204 mm
2.8	W	388 mm
	H	258 mm



ACF-SW/CD CASE PRO

151100001

Specification

- Durable road case for up to 108 CDs
- Butterfly latches
- Handle for easy transport
- Ball corners
- Strong aluminum profile
- Extra strong construction for road use

KG	L	321 mm
6.5	W	593 mm
	H	188 mm



CDs not included

ACF-SW/TOOLBOX

1521000079

The Toolbox flight case from Accu Case is a universal tool box. It offers safe transport, covers your working tools from dust and damage. There's a carrying handle on the front together with 2 lockable butterfly-locks.

Specification

- Solid 7 mm thick plywood
- Strong aluminium profiles
- Steel ball corners
- Butterflylocks
- Rubber feet
- Color: black

KG	L	340 mm
4.0	W	480 mm
	H	180 mm



ACA/WHEEL BOARD

1531000002

Heavy duty wheel board

- 20 mm MDF Wood
- Black coated
- 100 mm Blue Wheels, two with brakes
- Cut out for handle - Corners with 45° cutoff
- Color: black

KG	L	670 mm
9.35	W	540 mm
	H	175 mm



ACA/CASE CART

1553000012

An easily foldable and portable Luggage Cart

Specification

- Wheels automatically swing out and fold up for easy storage.
- Extra sturdy and lightweight, extremely portable.
- Extends to a height of 101,7cm
- Smooth rolling 10cm diameter wheels
- Loading capacity: 54.5 kg



Softbags

Now there's an easy way for DJs and VJs to protect their lighting gear without breaching their budgets. Designed specifically for the mobile lighting market by a team with decades of experience in the industry, the case line covers a wide range of gear, from small lasers to centerpiece effects. The stylish black cases, work with lighting gear from all major suppliers.

Made of durable synthetic material the soft, padded cases protect a DJ's investment in lighting by safeguarding fixtures against nicks, dings and scratches. This not only preserves the outward appearance of lighting effects, it also extends their useful life.

Secure „view windows“ on nearly all cases make it easy to identify specific fixtures even after they've been packed. The cases' extra wide mouth design allows gear to be removed quickly and easily. Another convenient feature found in most cases is the secured zipped pocket for storing extra lamps, clamps and other accessories.

The cases offer an added benefit for performers on the go by allowing gear to be stacked without having to be boxed. This saves valuable transport space in cars and vans.

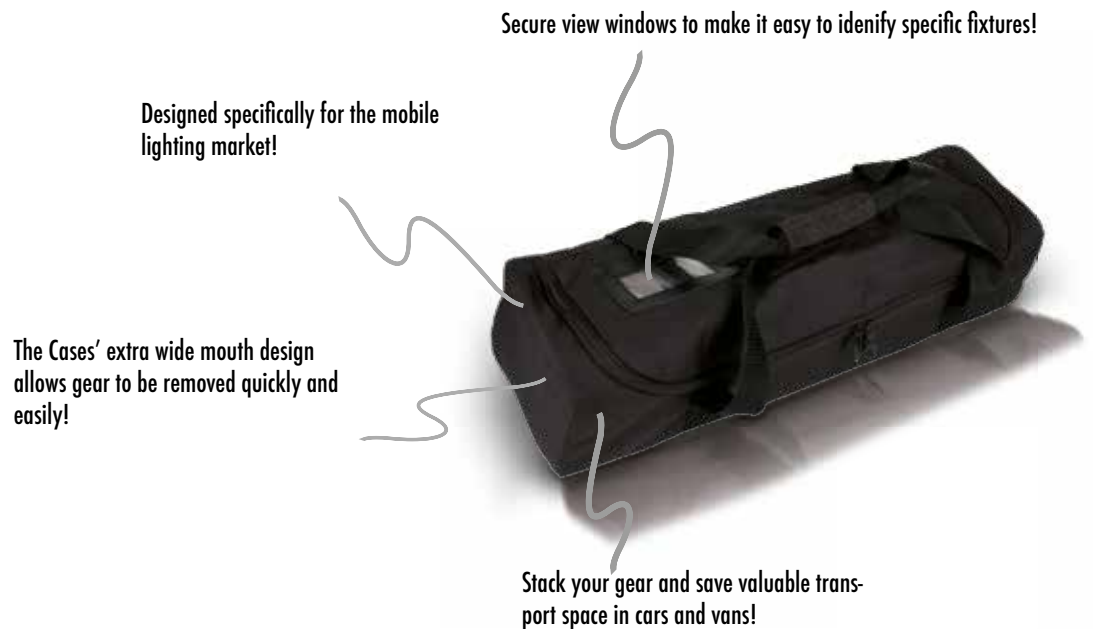



1521000190



F4 PAR Bag

Soft padded transport bag for modern LED Flat Pars.

The Flat Pak Bag 4 is a soft padded transport bag for all modern Flat Pars. It offers you a convenient transport possibility for your equipment without wasting space in your car. It fits up to 4 Flat Pars.

Another big benefit of the Flat Pak Bag is the storage during your gig. Don't pay for storage of bulky wooden flight cases or fill your tiny DJ booth. Just fold it together and store it.

The bag is made from durable synthetics which makes it dirt-repellent and lightweight. In the additional side bag you can store cables and adapters as well.



1521000191



F8 PAR Bag

Soft padded transport bag for modern LED Flat Pars.

The Flat Pak Bag 8 is a soft padded transport bag for all modern Flat Pars. It offers you a convenient transport possibility for your equipment without wasting space in your car. It fits up to 8 Flat Pars.

Another big benefit of the Flat Pak Bag is the storage during your gig. Don't pay for storage of bulky wooden flight cases or fill your tiny DJ booth. Just fold it together and store it.

The bag is made from durable synthetics which makes it dirt-repellent and lightweight. In the additional side bag you can store cables and adapters as well.



1521000278

WiFLY TOUGH BAG

Specification

- Durable semi-hard case for transporting of lighting fixtures
- Fits four (4) ADJ WiFLY Pars and one (1) ADJ WiFLY NE1 or WiFLY RGBW8C
- Wheels & pull handle
- Custom fix interior protects lighting fixtures during transport and storage
- Great for rentals companies and mobile lighting designers and entertainers on the go
- Dimensions & weight: TBA



1521000255

Tough Bag ISPx4

Specification

- Durable semi-hard case for transporting of lighting fixtures
- Fits of the following: Inno Pocket Spot, Inno Pocket Spot Pearl, Inno Pocket Wash, Inno Pocket Z4, Inno Pocket Beam Q4 & Inno Pocket Spot LZR
- Wheels & pull handle
- 5 compartments: 4 for lighting fixtures, 1 for cables
- Custom fix interior protects lighting fixtures during transport and storage
- Great for rentals companies and mobile lighting designers and entertainers on the go
- Dimensions (LxWxH): 1000x260x320mm
- Weight: 6.8 kg. (no fixtures inside)





L 230 mm
W 230 mm
H 310 mm

6011000019

ASC-AC-115

Saga / Stage Wash Style!

- Affordable padded soft cases designed to protect and extend the life of mobile lighting fixtures
- Great for mobile DJs, Karaoke rigs and working bands
- Saves valuable transport space by allowing fixtures to be stacked without having to be boxed

Works With All Brands of Lighting Fixtures!



L 460 mm
W 220 mm
H 220 mm

6011000020

ASC-AC-120

Fogger / Intelligent Scanner Style

- Affordable padded soft cases designed to protect and extend the life of mobile lighting fixtures
- Great for mobile DJs, Karaoke rigs and working bands
- Saves valuable transport space by allowing fixtures to be stacked without having to be boxed

Works With All Brands of Lighting Fixtures!



L 530 mm
W 330 mm
H 215 mm

6011000054

ASC-AC-131

- Works with all brands of lighting fixtures
- Affordable padded soft cases designed to protect and extend the life of mobile lighting fixtures
- Great for mobile DJs, Karaoke rigs and working bands
- Extra's for storing extra Lamps, Clamps, Cables and other Accessories
- Saves valuable transport space by allowing fixtures to be stacked without having to be boxed
- Secure „view windows“ on Arriba Cases make it easy to identify specific fixtures even after they've been packed, or place your business card in the window for personal identification
- Extra wide mouth design allows gear to be removed quickly and easily.

Works With All Brands of Lighting Fixtures!



6011000021

L 330 mm
W 330 mm
H 300 mm

ASC-AC-125

Mid-Size Intelligent Scanner

- Saves valuable transport space by allowing fixtures to be stacked without having to be boxed
- Extra wide mouth design allows gear to be removed quickly and easily

Works With All Brands of Lighting Fixtures!



6011000051

L 355 mm
W 205 mm
H 200 mm

ASC-AC-126

The ASC-126 is primarily designed to protect several of the American DJ laser products, such as: Royal 3D, Royal Sky, Duo Scan RG, Atmospheric RG LED and Hypnotic RG. The ASC-126 fits other lighting products and brands as well; make sure to check the dimensions of your product to see if it fits this case.

- Great for mobile DJs, Karaoke rigs and working bands
- Saves valuable transport space by allowing fixtures to be stacked without having to be boxed
- Extra wide mouth design allows gear to be removed quickly and easily

Works With All Brands of Lighting Fixtures!



6011000022

L 310 mm
W 320 mm
H 190 mm

ASC-AC-130

Pocket Scan / Comet Style Case

- Secured zipped pocket for storing extra lamps, clamps, cables and other accessories
- Saves valuable transport space by allowing fixtures to be stacked without having to be boxed

Works With All Brands of Lighting Fixtures!

Works With All Brands of Lighting Fixtures!



L 480 mm
W 250 mm
H 180 mm

6011000023

ASC-AC-135

Compact Intelligent Scanner

- Affordable padded soft cases designed to protect and extend the life of mobile lighting fixtures
- Great for mobile DJs, Karaoke rigs and working bands
- Saves valuable transport space by allowing fixtures to be stacked without having to be boxed



L 580 mm
W 250 mm
H 250 mm

6011000024

ASC-AC-140

Larger Scanner Style

- Affordable padded soft cases designed to protect and extend the life of mobile lighting fixtures
- Secured zipped pocket for storing extra lamps, clamps, cables and other accessories

Works With All Brands of Lighting Fixtures!



L 620 mm
W 330 mm
H 340 mm

6011000025

ASC-AC-142

Larger Scanner Style Prop & Gear Case

- Saves valuable transport space by allowing fixtures to be stacked without having to be boxed
- Secure „view windows“ on Arriba Cases make it easy to identify specific fixtures even after they've been packed, or place your business card in the window for personal identification

Works With All Brands of Lighting Fixtures!



L 762 mm
W 356 mm
H 356 mm

6011000026

ASC-AC-144

Larger Scanner Style Prop & Gear Case

- Affordable padded soft cases designed to protect and extend the life of mobile lighting fixtures
- Great for mobile DJs, Karaoke rigs and working bands
- Secured zipped pocket for storing extra lamps, clamps, cables and other accessories

Works With All Brands of Lighting Fixtures!



L 470 mm
W 410 mm
H 270 mm

6011000027

ASC-AC-145

Aggressor / Double Derby Style Case

Works With All Brands of Lighting Fixtures!

Mid-Size Intelligent ScannerSoftCase

- Saves valuable transport space by allowing fixtures to be staked without having to be boxed
- Extra wide mouth design allows gear to be removed quickly and easily



L 1336 mm
W 171 mm
H 121 mm

6011000039

ASC-AC-210

Works With All Brands Of LED Bar Fixtures

- Protects American DJ Mega Bar UV 50/100, Rainbox Tube 2,
- Mega Pixel LED, Mega Bar LED
- Padded soft case designed to protect and extend the life of mobile lighting fixtures
- Designed for 2x Mega Bar 50RGB LED Bars



L 1664 mm
W 394 mm
H 394 mm

6011000036

ASC-AC-185

Rolling Case For Truss

Protects These Lighting Models:
Dura Truss System & Other Truss Brands



6011000053

L 1600 mm
W 225 mm
H 150 mm

ASC-AC-63

The AC-63 is primarily designed to protect two lighting tripod stands from American DJ (such as the LTS-2, LTS-6 and LTS-10). They may fit other lighting tripods and brands as well; make sure to check the dimensions of your product to see if it fits this case.

- Great for mobile DJs, Karaoke rigs and working bands
- Saves valuable transport space by allowing fixtures to be stacked without having to be boxed
- Extra wide mouth design allows gear to be removed quickly and easily

Works With
All Brands of
Lighting Fixtures!



6011000031

L 381 mm
W 356 mm
H 457 mm

ASC-AC-160



Starball / Centerpiece Style Case

- Affordable padded soft cases designed to protect and extend the life of mobile lighting fixtures
- Great for mobile DJs, Karaoke rigs and working bands
- Saves valuable transport space by allowing fixtures to be stacked without having to be boxed

Works With
All Brands of
Lighting Fixtures!

L 495 mm
W 350 mm
H 50 mm

6011000050

ASC-AS-190

The ASC-AS-190 fits American Audio VMS4, VMS2, Encore 1000, Encore 2000; Native Instruments Traktor Kontrol S4, Denon DN-MC6000, Hercules DJ Console RMX, DJ Console 4-Mx, DJ Control Steel Controller, DJ Console Mk4

Specification

- Protective soft bag for Midi Controllers + 1 Laptop
- Extra pads inside to fit a variety of Midi Controllers
- Extra compartment for one 17-inch laptop
- Pocket to store extra cables and power adapters
- Shoulder strap
- Extra strap to fit on a rolling bag
- Case inside dimensions (LxWxH): 495x350x50mm
- Fits: American Audio VMS4, VMS2, Encore 1000, Encore 2000; Native Instruments Traktor Kontrol S4, Denon DN-MC6000, Hercules DJ Console RMX, DJ Console 4-Mx, DJ Control Steel Controller, DJ Console Mk4



The ATP & ACR Series are part of the Stackable Rolling Series; multi purpose padded bag for the entertainer on the go. Each bag is made of heavy duty materials to survive life on the road. The large inner dimensions along with it's configurable padded dividers allow for a wide variety of lighting, audio equipment, cables, extension cords, microphones and all types of electronic equipment to be stored and transported. The Stackable Rolling Series helps you protect your valuable investment, allows for easier transport to and from events, and keep gear dust free when your not using it.



6011000046

ASC-ACR22

Bottom Roller Case

- May be used together with the ATP-Series (sold seperately) by use of it's rear strap
- Includes two configurable padded dividers
- Heavy duty design and zippers
- 1/2 inch padding

Works With
All Brands of
Lighting Fixtures!



ASC-ATP22

6011000049



Top Stackable Case

- Fits onto the ACR-Series rolling bag (sold seperately) by use of it's rear strap
- Includes two configurable padded dividers
- Heavy duty design and zippers
- 1/2 inch padding

Works With
All Brands of
Lighting Fixtures!



CABLES



Speaker cable on Roll 2x 0,75mm² / flat

AC-SC2-0,75/100R



Speaker cable on Roll
 Conductors: 2
 Ø: 2x 0,75mm²
 Construction: flat
 Length: 100m



Available colors:

100 m AC-SC2-0,75/100R code: 1612100001 transparent

Speaker cable on Roll 4x 2,5mm² / round

AC-SC4-2,5/100R

Speaker cable on Roll
 Conductors: 4
 Ø: 4x 2,5mm²
 Construction: round
 Length: 100m



Available colors:

100 m AC-SC4-2,5/100R code: 1612100011 black

SPEAKER CABLE ON ROLL - 100m

Speaker cable on Roll 2x 2,5mm² / round

AC-SC2-2,5/100R-B

Speaker cable on Roll
 Conductors: 2
 Ø: 2x 2,5mm²
 Construction: round
 Length: 100m



Available colors:

100 m AC-SC2-2,5/100R-B code: 1612100010 black

Speaker cable on Roll 2x 1,5mm² / flat

AC-SC2-1,5/100R



Speaker cable on Roll
 Conductors: 2
 Ø: 2x 1,5mm²
 Construction: flat
 Length: 100m



Available colors:

100 m AC-SC2-1,5/100R code: 1612100002 transparent

Speaker cable on Roll 2x 2,5mm² / flat

AC-SC2-2,5/100R

Speaker cable on Roll
 Conductors: 2
 Ø: 2x 2,5mm²
 Construction: flat
 Length: 100m



Available colors:

100 m AC-SC2-2,5/100R code: 1612100003 transparent

Speaker cable on Roll 2x 4mm² / flat

AC-SC2-4/100R



Speaker cable on Roll
 Conductors: 2
 Ø: 2x 4mm²
 Construction: flat
 Length: 100m



Available colors:

100 m AC-SC2-4/100R code: 1612100004 transparent

MICROPHONE CABLE ON ROLL - 100m

Microphone Cable on Roll / round

AC-MC/100R



Conductors: 3
 Length: 100m

Available colors:

100 m AC-MC/100R-B code: 1612100005 black
 100 m AC-MC/100R-G code: 1612100006 green
 100 m AC-MC3/100R-R code: 1612100007 red
 100 m AC-MC3/100R-Y code: 1612100008 yellow
 100 m AC-MC3/100R-BL code: 1612100009 blue



2x XLR female - 2x 6,3 Jack male

AC-2XF-2J6M/3



Connector side A: 2x XLR (F) /3-pin
Connector side B: 2x Jack 6,3 mono



Available lengths:

- 1,5 m AC-2XF-2J6M/1,5 code: 1611000039
- 3 m AC-2XF-2J6M/3 code: 1611000027



6,3 Jack stereo - 2x Jack mono

AC-J6S-2J6M



Connector side A: 2x 6,3 Jack male
Connector side B: 6,3 Jack stereo



Available lengths:

- 3 m AC-J6S-2J6M/3 code: 1611000028



2x XLR male - 3,5 jack stereo male

AC-J3S-2XM



Connector side A: 2x XLR (m) /3-pin
Connector side B: 1x 3,5 Jack stereo



Available lengths:

- 1,5 m AC-J3S-2XM/1,5 code: 1611000042
- 3 m AC-J3S-2XM/3 code: 1611000043



2x RCA male - 3,5 jack stereo male

AC-J3S-2RM



Connector side A: 2x RCA (m)
Connector side B: 1x 3,5 Jack stereo



Available lengths:

- 1,5 m AC-J3S-2RM/1,5 code: 1611000040
- 3 m AC-J3S-2RM/3 code: 1611000041



2x 6,3 Jack - 3,5 jack stereo male

AC-J3S-2J6M



Connector side A: 2x 6,3 Jack male
Connector side B: 1x 3,5 Jack stereo



Available lengths:

- 1,5 m AC-J3S-2J6M/1,5 code: 1611000044



2x 6,3 Jack male - 2x RCA male

AC-2R-2J6M



Connector side A: 2x 6,3 Jack male
Connector side B: 2x RCA (m)



Available lengths:

- 1,5 m AC-2R-2J6M/1,5 code: 1611000049
- 3 m AC-2R-2J6M/3 code: 1611000007



MAIN POWER CORE & POWER ADAPTER

IEC extension Cable

IEC extension cable 2m male/female



Type:

- 2 m AC-IEEXT-1/2 code: 1631000004

UK main cord / IEC

UK main cord mal / IEC female
10A 3x1mm²



Type:

- 1,5 m AC-UK-IEC-1/1,5 code: 1631000005

Schuko - Powercon

Type:

- 1,8 m Power Con Schuko 1,8m 1239100185
- 3 m Power Con Schuko 3,0m 1239100270
- 7,5m Power Con Schuko 7,5m 1239100268
- 15m Power Con Schuko 15m 1239100267



UK main cord / S8 (Euro)

UK main cord mal / S8 female
10A 2x1mm²



Type:

- 1,5 m AC-UK-S8-1/1,5 code: 1631000003

AC-UKA/SCHUKO SCHUKO/UK Converter Plug

Converter Plug code: 1631000001



AC-UKA/EURO EURO/UK Converter Plug CP1B

Converter Plug code: 1631000002

UK Main Cord - Power Con

Type:

- 0,9m PC0,9 Power Con UK Plug 1239100195
- 1,8m PC1,8 Power Con UK Plug 1239100196



(Not All Images Are Shown)

Multicore on Cable Drum XLR - XLR

AC-MCR



Yellow plastic cable drum with braided nylon to protect the cables. Rotation lock, built in flange.

- 8 Channel, number coded, 15m XLR
- Multicore cable drum
- Cable diameter: 1 cm
- XLR metal connectors
- Weight: 5,5 Kg

Connector side: 8x XLR male
 Stage Box side: 8x XLR female
 15 m AC-MCR8/15 167000001



Speaker Cables Speaker - Speaker

AC-SP2-2,5

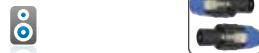

2x 2,5mm²

Connector side A: Speaker 2-pin
 Connector side B: Speaker 2-pin

Available lengths:

- 5 m AC-SP2-2,5/5 code: 1611000023
- 10 m AC-SP2-2,5/10 code: 1611000024
- 15 m AC-SP2-2,5/15 code: 1611000025
- 20 m AC-SP2-2,5/20 code: 1611000026



6,3 Jack stereo - 6,3 Jack stereo Cables

AC-J6S



Connector side A: Jack 6,3 stereo
 Connector side B: Jack 6,3 stereo

Available lengths:

- 1,5 m AC-J6S/1,5 1611000017
- 5 m AC-J6S/5 1611000018
- 10 m AC-J6S/10 1611000019



2x XLR male - 2x RCA male

AC-2XM-2RM



Connector side A: 2x XLR (m) /3-pin
 Connector side B: 2x RCA (m)

Available lengths:

- 1,5 m AC-2XM-2RM/1,5 1611000029
- 3 m AC-2XM-2RM/3 1611000034
- 5 m AC-2XM-2RM/5 1611000035



2x XLR male - 2x 6,3 Jack male

AC-2XM-2J6M



Connector side A: 2x XLR (m) /3-pin
 Connector side B: 2x Jack 6,3 mono

Available lengths:

- 1,5 m AC-2XM-2J6M/1,5 1611000036
- 3 m AC-2XM-2J6M/3 1611000037
- 5 m AC-2XM-2J6M/5 1611000038



RCA Cables

AC-R



Connector side A: RCA
 Connector side B: RCA

Available lengths:

- 0,5 m AC-R/0,5 1611000020
- 1 m AC-R/1 1611000021
- 3 m AC-R/3 1611000022



2x XLR male - 2x 6,3 Jack male stereo

AC-2J6S-2XM/3



Connector side A: 2x XLR (m) /3-pin
 Connector side B: 2x Jack 6,3 stereo

Available lengths:

- 3 m AC-2J6S-2XM/3 1611000033



2x XLR female - 2x RCA male

AC-2XF-2RM



Connector side A: 2x XLR (f) /3-pin
 Connector side B: 2x RCA (m)

Available lengths:

- 1,5 m AC-2XF-2R/1,5 1611000030



Microphone cable XLR/XLR

AC-XXMF



Connector side A: XLR (m) /3-pin
 Connector side B: XLR (f) /3-pin

Available lengths:

- 1m AC-XXMF/1 1611000008
- 3m AC-XXMF/3 1611000013
- 5m AC-XXMF/5 1611000010
- 10m AC-XXMF/10 1611000011
- 15m AC-XXMF/15 1611000009
- 20m AC-XXMF/20 1611000012

Microphone cable XLR/XLR PRO ACCU CABLE

AC-PRO-XXMF



Connector side A: XLR (m) /3-pin
 Connector side B: XLR (f) /3-pin

Available lengths:

- 0,5m AC-PRO-XXMF/0,5 1611000064
- 1m AC-PRO-XXMF/1 1611000065
- 3m AC-PRO-XXMF/3 1611000066
- 5m AC-PRO-XXMF/5 1611000067
- 10m AC-PRO-XXMF/10 1611000068
- 15m AC-PRO-XXMF/15 1611000069
- 20m AC-PRO-XXMF/20 1611000070

XLR male - 6,3 Jack stereo Cables

AC-XM-J6S



Connector side A: XLR (m) /3-pin
 Connector side B: Jack 6,3 stereo

Available lengths:

- 1,5m AC-XM-J6S/1,5 1611000047
- 3m AC-XM-J6S/3 1611000048

SPECIAL CABLES

Power + XLR (Audio) Cable

AC-COM-A



Side A: 1x Schuko (m) + 1x XLR (f)
 Side B: 1x IEC (f) + 1x XLR (f)

Available lengths:

- 10m AC-COM-A/10 code: 1611000005
- 20m AC-COM-A/20 code: 1611000006

Microphone cable XLR/XLR - 90° angle plug

AC-XXMF-90°



Connector side A: XLR (m) /90°/3-pin
 Connector side B: XLR (f) /90° /3-pin

Available lengths:

- 1,5m AC-XXMF/1,5-90 90° 1611000031
- 3m AC-XXMF/3-90 90° 1611000032

XLR female - 6,3 Jack stereo Cables

AC-XF-J6S



Connector side A: XLR (f) /3-pin
 Connector side B: Jack 6,3 stereo

Available lengths:

- 1,5m AC-XF-J6S/1,5 1611000045
- 3m AC-XF-J6S/3 1611000046

6,3 Jack mono - 6,3 Jack mono Cables

AC-J6M



Connector side A: Jack 6,3 mono
 Connector side B: Jack 6,3 mono

Available lengths:

- 1,5m AC-J6M/1,5 1611000014
- 5m AC-J6M/5 1611000015
- 10m AC-J6M/10 1611000016

3 Pin XLR + Powercon Combo Link Cable

AC3PPCON

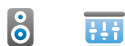

Side A: 1 Powercon Blue + 1 x DMX 3P (F)
 Side B: 1 Powercon Grey + 1 x DMX 3P (M)

Available lengths:

- 0,9m AC3PPCON3 1154000046
- 1,8m AC3PPCON6 1154000047
- 3,6m AC3PPCON12 1154000048

DMX - PREMADE CABLES

DMX cable XLR/XLR 3-pin

AC-DMX3



Connector side A: XLR (m) /3-pin
 Connector side B: XLR (f) /3-pin

Available lengths:

- 0,5m AC-DMX3/0,5 1621000018
- 1,5m AC-DMX3/1,5 1621000007
- 3m AC-DMX3/3 1621000008
- 5m AC-DMX3/5 1621000020
- 10m AC-DMX3/10 1621000009
- 15m AC-DMX3/15 1621000010
- 30m AC-DMX3/30 1621000011

DMX cable XLR/XLR 5-pin

AC-DMX5



Connector side A: XLR (m) /5-pin
 Connector side B: XLR (f) /5-pin

Available lengths:

- 1,5m AC-DMX5/1,5 1621000014
- 3,0m AC-DMX5/3 1621000015
- 5,0m AC-DMX5/5 1621000021
- 10m AC-DMX5/10 1621000023
- 15m AC-DMX5/15 1621000016
- 30m AC-DMX5/30 1621000017

DMX CABLE ON ROLL - 100m

DMX cable on Roll 3

AC-DMX3/100R



DMX cable on Roll

Conductors: 3
 Impedance: 110 Ohm
 Length: 100m

1622100001

DMX cable on Roll 5

AC-DMX5/100R



DMX cable on Roll

Conductors: 5
 Impedance: 110 Ohm
 Length: 100m

1622100002

DMX cable XLR/XLR 90°/ 3-pin

AC-XMXF



Connector side A: XLR (m) /3-pin /90°
 Connector side B: XLR (f) /3-pin / 90°

Available lengths:

- 1,5m AC-DMX3/1,5-90 code: 1621000022
- 3m AC-DMX3/3-90 code: 1621000019

DMX Adapter 3-pin (m) to 5-pin (f)

DMX Adapter 3-pin (male) to 5-pin (female)
 5 cm



Available lengths:

- 5cm AC-DMXT/3M5F 1621000012

DMX Adapter 3-pin (f) to 5-pin (m)

DMX Adapter 3-pin (female) to 5-pin (male)
 5cm



Available lengths:

- 5cm AC-DMXT/5M3F 1621000013

DMX Terminator XLR 3-pin (m)

DMX terminator XLR 3-pin, SET of 2



AC-DMXTERM-3/SET 1613000030 (392128)

DMX Terminator XLR 5-pin (m)

DMX terminator XLR 5-pin, SET of 2



AC-DMXTERM-5/SET 1613000031

Extension Cable LED Pixel Tube 360

- Code: 1611000075 - 3 m
- Code: 1611000076 - 5 m
- Code: 1611000077 - 10 m



IP EXTENSION CABLES

IP Ext for Wifly EXR Bar IP

Available lengths:

- 2 m Power IP ext. cable 2m code: 1226100314
- 5 m Power IP ext. cable 5m code: 1226100316



IP Ext for Wifly EXR HEX5/QA5 IP

Available lengths:

- 2m Power IP ext. cable 2m 1226100304
- 5 m Power IP etx. cable 5m 1226100306
- 10m Power IP ext. cable 10m 1226100308



IP Ext for Wifly PAR QA5 IP

Available lengths:

- 1m Power IP ext. cable 1m 1226100282
- 3m Power IP etx. cable 3m 1226100306
- 5m Power IP ext. cable 5m 1226100284



AUDIO ADAPTER

XLR male - Jack 6,3mm male mono

XLR 3-pin male - Jack 6,3mm male mono

Type:
AC-A-XM3/J6M 1613000004



XLR female - Jack 6,3mm female stereo

XLR 3-pin female - Jack 6,3mm female stereo

Type:
AC-A-XF3/J6S 1613000007



XLR female - XLR female

XLR 3-pin female - XLR 3-pin female

Type:
AC-A-XF3/XF3 1613000009



XLR male - RCA male

XLR male - RCA male

Type:
AC-A-XM3/RM 1613000011



XLR female - Jack 6,3mm male mono

XLR 3-pin female - Jack 6,3mm male mono

Type:
AC-A-XF3/J6M 1613000005



XLR male - Jack 6,3mm female stereo

XLR 3-pin male - Jack 6,3mm female stereo

Type:
AC-A-XM3/J6S 1613000006



XLR male - XLR 3-pin male

XLR 3-pin male - XLR 3-pin male

Type:
AC-A-XM3/XM3 1613000008



XLR female - RCA male

XLR 3-pin female - RCA male

Type:
AC-A-XF3/RM 1613000010



XLR female - RCA female

XLR 3-pin female - RCA female

Type:
AC-A-XF3/RF 1613000015



2x RCA female - Jack 6,3mm male stereo

2x RCA female - Jack 6,3mm male stereo

Type:
AC-A-RF/J6S 1613000013



RCA female - RCA female

RCA female - RCA female

Type:
AC-A-RF/RF 1613000014



Jack 6,3mm mono female - RCA Cinch male

Jack 6,3mm mono female - RCA Cinch male

Type:
AC-A-J6/RCA-M 1613000017



Coupler female - female for Speaker

Coupler female - female for Speaker 4-pin

AC-A-SPF4/SPF4 1613000003



XLR male - RCA female

XLR 3-pin male - RCA female

Type:
AC-A-XM3/RF 1613000016



RCA female - 6,3mm Jack male mono

RCA female - 6,3mm Jack male mono

Type:
AC-A-RF/J6M 1613000012



3,5 Jack female stereo - 6,3 Jack stereo male

3,5 Jack female stereo - 6,3 Jack stereo male

Type:
AC-A-J3/J6 3,5 1613000002



CABLE CONNECTORS

RCA male (SET of 2)

RCA Cinch plug male gold - SET

Type:
AC-C-RMG/SET 1613000028



XLR female 3-pin

XLR 3-pin female

Type:
AC-C-X3F 1613000018



Jack 6,3 mm /male / mono

Jack male 6,3mm mono

Type:
AC-C-J6M 1613000022



Jack 6,3 mm /female / stereo

Jack female 6,3mm stereo

Type:
AC-C-J6FS 1613000026



XLR - 90° / female 3-pin

90° XLR 3-pin female

Type:
AC-C-XF-90 1613000033



PANEL CONNECTORS

Speaker 4-pin panel / female

Speaker 4-pin panel / female

Type:
AC-C-PS4M 1613000025



XLR 3-pin panel metal/ female

XLR 3pin female panel metal

Type:
AC-C-XF3 1613000020



Jack 6,3 stereo panel / female

Jack 6,3 stereo panel / female

Type:
AC-C-PJ6S 1613000027



XLR 3-pin panel metal /male

XLR 3pin male panel metal

Type:
AC-C-XM3 1613000024



90° RCA male - RCA female Set

90° RCA male - RCA female

Type:
AC-A-RMF-90 1613000032



RCA male (SET of 2)

RCA Cinch plug female gold - SET

Type:
AC-C-RFG/SET 1613000029



XLR male 3-pin

XLR 3-pin male

Type:
AC-C-X3M 1613000019



Jack 6,3 mm /male / stereo

Jack male 6,3mm stereo

Type:
AC-C-J6S 1613000023



Speaker male/ 4-pin

Speaker plug male / 4-pin

Type:
AC-C-SP4 1613000021



XLR - 90° / male 3-pin

90° XLR 3-pin male

Type:
AC-C-XM-90 1613000034



LIGHTING CONTROLLERS





NEW! My DMX 3

131000051



New Features:

- Play multiple scenes at a time
- Arrange scenes into groups
- Sound-light with BPM audio analysis and pulse analysis
- Live snapshots
- Live scene dimming and scene speed controls
- Stand Alone backup memory
- BPM tap
- Flash scenes
- Blind editing - edit scenes without outputting the DMX
- Fully compatible with myDMX 2.1 software
- Up to 10 universes when used in multiples
- Windows and Mac installers that will download the latest ssl library with an internet connection upon install.
- "Maintenance" application that installs with the program to check for component updates or new versions of the software.
- "Cloud search for profiles" Search for the latest and greatest fixture profiles from within the program itself, no more hunting through dropbox
- Improved multi Pan and Tilt support





AIRSTREAM DMX

1226100318

WiFLY NEI

1226100296



Specification

- Creates wireless bridge between your Wifi device and ADJ lighting products equipped with WiFly or wired DMX512
- Allows you to use your iPhone or iPad as a lighting controller using the Airstream DMX app
- Compatible with all ADJ WiFLY and Elation Efly products
- Magnetic bottom plate for temporary, quick and easy mounting to metal fixtures or objects.
- Quick lock bracket included.
- Up to 2500 wireless feet (open line of sight) when using other "EXR Extended Range" WiFLY products
- One transmitter can send to many receivers using the same radio channel
- 14 WiFly Channels
- 3-pin DMX Out
- Wireless Frequency: 2.4 GHz DSSS
- Power Supply: DC 9-12V
- Dimensions (LxWxH): 5" x 7" x 2.5" / 125 x 175 x 62mm
- Weight: 1 lbs. / 0.5 kg.

Features:

- 432 Channel DMX Controller with ADJ's WiFLY Transceiver Wireless DMX on-board.
- Control up to 12 individual fixtures
- Designed for controlling moving lights and LED Pars of any brand that consist of 34 DMX channels or less
- Built-in effects generator for LED's and Moving Lights
- 12 Memories via 2 banks
- 4 Rotary Encoders for Channel & Function Control
- Master Dimmer Fader Control
- Strobe Rate Fader Control
- 6 Mode buttons (Fixture, Color, Gobo, Effect, Show, & Pause)
- 12 Multi-function buttons
- Blackout button
- Universal USB Port (USB Stick Included)

Tech Specs:

- DMX output connector: 3-pin XLR
- Power In: 9-12V DC min 300mA UL approved power supply (Included)
- Power consumption: 3.6 Watts
- Size: 12.8" x 7.25" x 2.75" (325 x 185 x 68.7mm)
- Weight: 4.4 lbs. (2 kgs.)

MyDMX BUDDY

131000017

MyDMX Buddy is a scaled down, more economical version of myDMX 2.0. Out of the package, myDMX software will run in limited mode (No 3D visualizer, Easy Remote or Midi features). However, these features plus other upgrades can be purchased at www.dmxsoft.com.

Main Features:

- For use with any DMX512 compatible fixture
- Easy Setup, Programming and Playback
- Upgrades available at dmxsoft.com
- Fixture Library Includes over 10,000 Fixture profiles from over 500 Manufactures
- Compatible with myDMX 2.0. For PC & Mac
- 256 DMX Channel, Software based, Control System
- Compatible with Mac OS and Windows, 32 & 64-bit (XP, Vista, 7 & 8)
- 1-Year Limited Warranty
- Dimensions (LxW): 3" x 1" / 75 x 18mm



MyDMX Buddy Includes:

- USB / DMX Interface
- USB Cable



Mini USB port located at the bottom

D6 BRANCH

132100062

The D6-Branch is a 6-way DMX-Splitter that can be directly mounted onto truss with its integrated Velcros or by clamp.

- 6-way DMX Splitter/Booster
- Can be mounted directly onto truss
- 1 x 3-pin DMX In/Out on the Front
- 6 x 3-pin DMX Out on the rear side
- IEC power connector
- On/Off Switch



Mini USB port located at the bottom

SDC-6 FADERDESK V2 BLACK

1236100095

Specification

- No Confusing Configuration
- 6 Direct Channel Access Faders
- One Master Fader
- On/Off Switch
- Power Supply Included
- Compact and Lightweight
- Simple 6 Channel DMX Control
- 6 Individual Fader and One Masterfader
- 6 DMX Channels
- Very compact Design
- Easy Handling
- External Power Supply (9V DC/500mA)
- DMX Output: 3Pol (2+,3-/2-,3+)
- Weight: 0,8kg

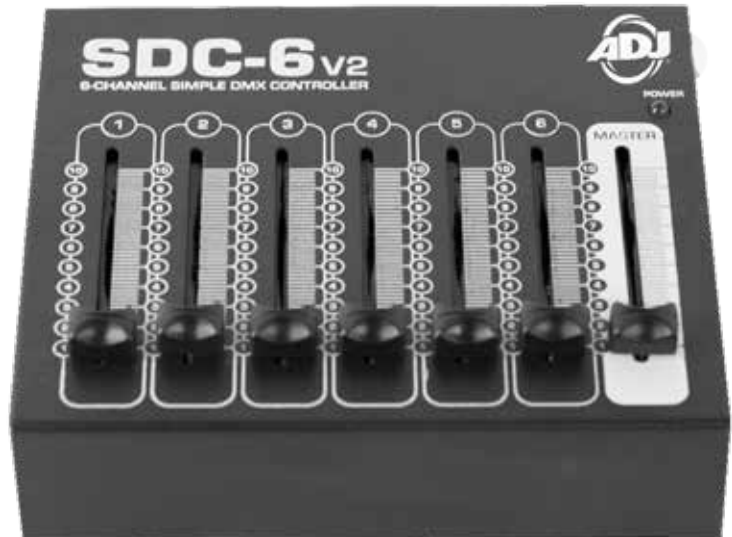

DMX Operator 384

1322000051

Specification

- 384 total DMX channels
- 12 fixtures x 32 channels each
- 8 channel faders x 4 channel banks
- Individual Speed & Fade Time faders
- 30 memory banks x 8 programmable scenes per bank
- 12 programmable chases, 240 steps per chase
- Assignable fade setting
- Manual control chase override
- Built-in microphone or line level input for audio triggering
- MIDI controllable
- Optional foot controller for chase step activation
- Onboard fog machine trigger button
- 7-segment LED display
- Ships with standard joystick module- optional jog wheel module available





WiFLY RGBW8C

1226100258



The WiFLY RGBW8C is a 64-channel RGB, RGBW, RGBA LED wireless DMX controller. It was designed to control any standard 3 or 4 channel group of LED fixtures where channel 1 is Red, channel 2 is Green, channel 3 is Blue and channel 4 is White or Amber. Up to 8 LED fixtures or fixture groups can independently be controlled via four fixture buttons. All LED fixtures or fixture groups must be set to run in DMX mode and be addressed four channels apart for independent control. The units control panel includes 9 direct access "Static Color/Chase" buttons, which contain pre-programmed color presets and chase programs, 3 user programmable color preset buttons, 4 multi function faders that control RGBW intensities on the fly, as well as chase program "Speed", chase program "Fade Time" and "Master Dimmer". There is also an array of 8 buttons used to select the operation mode, including RGB Fade, Auto Run, Color Macro, Chase, Sound Active, Strobe, Manual RGBW and Blackout modes. The WiFLY RGBW8C is one of the simplest and most versatile LED controllers available today. It's ideal for D.J.'s, nightclubs, lounges, bars and anyone that wants easy control of LED Par's, Bar's, Flood's or Panel's.

Specification

- Compact DMX-512 controller for RGB, RGBW and RGBA LED fixtures.
- Up to 8 channels can individually be controlled per fixture button.
- Built-In Wifly Transceiver, which will allow you control all Wifly compatible light fixtures wirelessly. (Can also be hard wired via 3 pin DMX cables)
- Built in RGB Fade, Auto program, Color Macro, Chase Programs
- 16x Operating Frequencies
- 4 Faders for manual RGBW or RGBA 4 channel control
- 3 user programmable color preset, direct access buttons
- 9 Color preset/Chase program direct access buttons
- Sound active mode via internal microphone
- Power consumption: 3.6 Watts
- Size: 13" x 5.75" x 2" (327 x 140 x 48mm)
- Weight: 3 lbs. (1.3 kgs.)





RGB3C IR

1321000075



RGBW 4C IR

1321000076

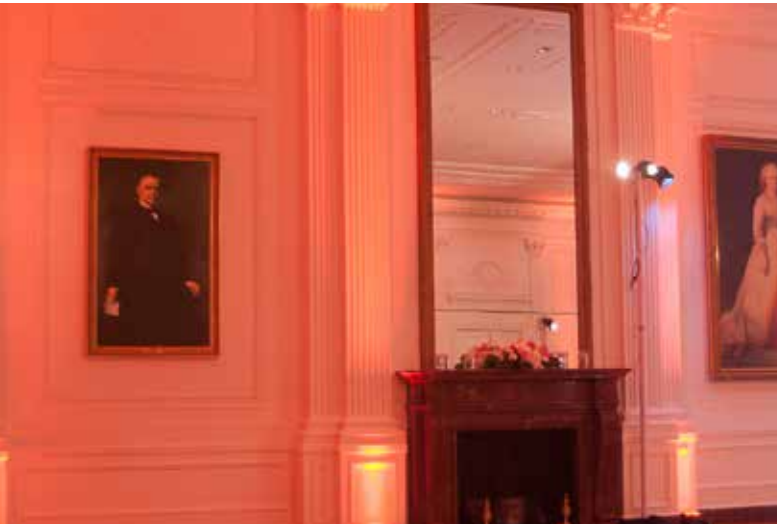

Specification

- Compact DMX512 controller for RGB, RGBW and RGBA LED fixtures
- Control up to 8 individual fixtures or fixture groups
- 3 Manual RGB Faders
- 9 direct access static color buttons
- 7 Static Colors
- 10 Chase Programs
- RGB and Auto modes
- Manual RGB intensity control mode
- Strobe Fader
- Blackout button
- ADJ LED RC2 Compatible (Sold Separately)
- DMX output connector: 3-pin XLR
- Power In: 9-12V 300mA (Included)
- Power consumption: 3.6 Watts
- Size: 8.7" x 5.5" x 2.5" (22 x 14 x 6.3cm)
- Weight: 1.8lbs. (0.8kgs.)

Specification

- Compact DMX512 controller for RGB, RGBW and RGBA LED fixtures
- Control up to 8 individual fixtures or fixture groups
- 3 user programmable color preset, direct access buttons
- 9 Color preset/Chase program direct access buttons
- Color Macro playback mode
- Manual RGBW intensity control mode
- RGB and Auto modes
- Sound active mode via internal microphone
- DMX output connector: 3-pin XLR
- ADJ LED RC2 Compatible (Sold Separately)
- Power In: 12VDC 500mA UL approved power supply (Included)
- Power consumption: 3.6 Watts
- Size: 12.9" x 5.5" x 1.9" (327 x 140 x 48mm)





SCENE SETTER

1322000048

Specification

- Conventional dimming console
- 24 total DMX channels
- 4200 programmable Scenes- password protected
- 48 programmable Chases- password protected
- Single & Mix Chase functions
- Blind & Dark functions
- 24 individual channel faders
- 24 bump buttons
- A / B Master Faders
- Tap Sync button for speed / fade override
- Independent Speed & Fade control
- Full-On button for 100% momentary output to all 24 channels

- Bright LCD display
- Use in conjunction with the Elation: DP-DMX20L, CYBER PAK, UNI PAK, DP-415 or DP-640
- Audio input and built in microphone for music sync functions
- Audio level fader
- Fog Machine input and trigger button- compatible with MB-1000, Stallion, Vapor- Flow, Fog Storm-1200 & 1700
- Polarity switch (2-, 3+, / 2+, 3-)
- Midi In, Out & Thru connectors
- Power: 120V. / 12V DC, 500mA. (Included) *Also available in 220V
- Dimensions: 10.5"L x 19"W x 3"H
- Weight: 11 lbs



DMX OPERATOR I

1322000046

Specification

- 192 DMX channel moving light controller
- 12 fixtures- up to 16 channels each
- 240 programmable Scenes
- 6 programmable Chases- up to 99 steps each
- Built in microphone for music sync function
- Tap Sync button for speed / fade override
- Bright 4-segment LED display
- Fog Machine input and trigger button- compatible with MB-1000, Stallion, Vapor Flow, Fog Storm-1200 and Fog Storm-1700
- Polarity switch (2-, 3+, / 2+, 3-)
- Midi input
- One DMX 3-pin XLR output
- Power supply: 120V. / 9-12V DC, 220mA. (Included) *Also available in 220V
- Dimensions: 5.25"L x 19"W x 2.5"H (Occupies 3 rack spaces)
- Weight: 5 lbs

LED MASTER (Klingnet Software)

131000026

LEDMaster is an all-in-one media solution that will allow you to create the most dynamic LED light shows. Based on our Kling-Net protocol, LEDMaster will take your LED light show to the next level. LEDMaster and KlingNet work together to do all the hard work for you, making operation simpler than ever. Kling-Net adds a layer of 'intelligence' to even the most simple LED devices, enabling it to talk directly with LEDMaster. This then enables the LED devices to configure themselves automatically, removing the need for complicated setup processes. KlingNet protocol is found imbedded in several ADJ and Elation fixtures, such as ADJ's Illusion Dotz 4.4, Illusion Dotz 3.3, Ultra Kling Bar 18, Flash Kling Panel 64 and Elation's EZ Kling interface, which can be used to run ANY LED pixel controllable DMX product. Designed in 3 steps, Mapping, Programming and Performance, LEDMaster is one of the most powerful and easy to use media softwares of its kind.

Features:

- Video control software for use with Kling-Net compatible LED fixtures
- Compatible with EZ-Kling box
- 3 Program Modes: Mapping mode; Scene Programming mode; Performance mode
- Mapping mode automatically recognizes Kling-net fixtures
- Scene programming mode allows for users to create scenes
- Performance mode allows for scenes to be triggered live
 - Auto-configuring with a large range of fixtures like Flash Kling Panel 64, Flash Kling Batten, Flash Kling Strip, Pixel Kling10C, Illusion Dotz 4.4 & 3.3, Asteroid 1200, all Pixel-controlled DMX-fixtures via EZ-Kling BOX, Ultra Kling Bar 18 and many others.

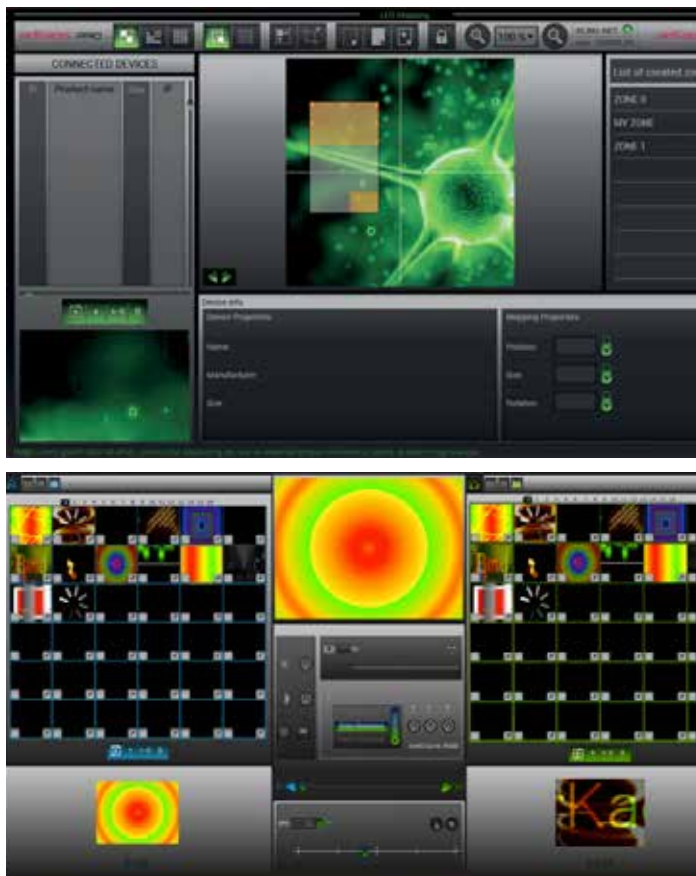

UC3 CONTROLLER

1321000046



The UC3 provides easy-to-use control of various American DJ lighting fixtures

- Mode Selection: Different run modes, e.g. fast/slow, audio/manual/ auto, position, latch, etc., correspond to different functions
- Function Selection: Implements a wide variety of effects, like strobe, X/Y moving pattern selection, gobo/ color changing, X/Y position setting, etc. Functions vary with different fixtures
- Cable length: Approx. 32 ft. / 9.75 mm
- Connection: 1/4 Stereo plug
- Dimensions: 3.54"x2.36"x.78" / 90x60x20mm
- Weight: 1 lbs. / .45 kgs.

UC3 Series easy-to-use lighting controllers are compatible with the following ADJ lighting fixtures:

Color Burst 8 DMX, Crazy 8, Dekker LED, Dotz Flood, Event Bar DMX, Event Bar Pro, Event Bar Q4, Freq 5, H2O DMX Pro, Inno Beam LED, Inno Color Beam LED, Inno Color Beam Quad 7, Inno Roll HP, Inno Scan HP, Inno Spot LED, Inno Spot Pro, Inno Spot Elite, Jelly Dome, Matrix Beam LED, Monster Beam, Quad Phase HP, Quad Scan Pro, Revo Sweep, SP-1500 DMX, Spherion Tri LED, Sweeper Beam LED, Sweeper Beam Quad, Vortex 1200, X-Move LED 25R

UNI PAK-MKII

1330000003



- Compact, 1 channel Dimmer/Switch Pack
- On-board and external HTP (Highest Takes Precedence) slider
- Standard DMX-512 protocol
- Dim preset - Dim limiter settings
- LED display makes it easy to set DMX channels
- 3 pin XLR In/Out
- Two standard AC 3-prong Edison plugs
- Easy to use mounting bracket
- Maximum power: 10A
- Dimensions (LxWxH): 7.25" x 3.625" x 2.625" / 184x92x92mm
- Weight: 3 lbs. / 1.3 kgs.

ADJ LED RC



1321000061

Specification

- Black Out: Turns fixture On/Off
- Auto Run: Automatically run through built-in programs
- Program Selection: Access units built-in programs
- Flash: Strobe effect
- Speed: Control speed of Auto Run
- DMX Mode Select
- Sound Active: Activates sound active mode
- Slave: Designates the fixture as a "slave" fixture in the Master/Slave configuration
- Set Address: Set DMX Address on a fixture
- RGB Buttons: Adjust RGB colors with the "+" and "-" buttons
- + and - Buttons: Adjust flash rate, speed of the Auto Run and Program Selection

ADJ RFC



1223200026

Specification

- Black Out: Turns fixture On/Off
- Auto Run: Automatically run through built-in programs
- Program Selection: Access units built-in programs
- Flash: Strobe effect
- Speed: Control speed of Auto Run
- Sound Active: Activates sound active mode
- RGB Buttons: Adjust RGB colors with the "+" and "-" buttons
- + and - Buttons: Adjust flash rate, speed of the Auto Run and Program Selection

ADJ LED RC2



1226200027

Specification

- Black Out: Turns fixture On/Off
- Program Selection: Access units built-in programs
- Flash: Strobe effect mode
- Speed: Activates the speed control of programs
- DMX Mode Select
- Sound Active: Activates sound active mode
- Slave: Designates the fixture as a "slave" fixture in the Master/Slave configuration
- Set Address: Set DMX Address on a fixture
- RGBAW Buttons: Adjust RGBAW colors with the "+" and "-" buttons
- + and - Buttons: Adjust flash rate speed, program speed, sound sensitivity and program selection

ADJ DOTZ RF



1223200036

Specification

- Black Out: Turns fixture On/Off
- Fade: Fades current color gradually
- Color: cycles through preset colors
- Program Selection: Access units built-in programs
- Auto Run: automatically cycles through built in programs
- Sound Active: Activates sound active mode
- Light 1 & 2 On/Off: Turns fixtures on/off (currently functions with the Dotz TPar System only)
- + / - adjusts fade, colors, sound sensitivity and program selection

ADJ LED RC3



1226200046

Specification

- Black Out: Turns fixture On/Off
- Auto Run
- Program Selection: Access units built-in programs
- Flash: Strobe effect mode
- Speed: Activates the speed control of programs
- DMX Mode Select
- Sound Active: Activates sound active mode
- Slave: Designates the fixture as a "slave" fixture in the Master/Slave configuration
- Set Address: Set DMX Address on a fixture
- Dimming Buttons: Adjust (WW, CW, A) colors with the "+" and "-" buttons. + and - Buttons: Adjust flash rate speed, program speed, sound sensitivity and program selection

ADJ UV IR



9900007217

Specification

- IR Remote Button: Turns Fixture On/Off
- Strobing Speed: Controls the strobing speed of the UV Fixture

ADJ UC IR



1321000074

Specification

- Stand By: Black Out
- Full On: Turns all lights on
- Fade/Gobo: Activates fade function or Cycles through gobos
- Dimmer +: Increases dimming time
- Strobe: Activates Strobe effect
- Colors: Cycles through color
- Dimmer -: Decreases dimming time
- Sound On: Activate Sound Active mode
- Show: Activates Built-in Programs
- Sound Off: Turns off Sound Activity mode

ADJ DOTZ PAR RF



1223200035

Specification

- Black Out: Turns fixture On/Off
- Fade: Fades current color gradually
- Color: cycles through preset colors
- Program Selection: Access units built-in programs
- Auto Run: automatically cycles through built in programs
- Sound Active: Activates sound active mode
- + / - adjusts fade, colors, sound sensitivity and program selection

AMERICAN AUDIO PRODUCTS



CPX SERIES

high powered speakers



CPX 8A

2-way active speaker

1161220011

FEATURES

- . 2-way Speaker with High Efficiency Class D Amplifier
- . 200W Built-in Bi-amplifier
- . Time Aligned Electronic Crossover
- . 5 M8 Rigging points
- . Stand Mountable
- . Heavy Duty steel grill
- . Ergonomic handles
- . Power and Clip LED Indicators
- . XLR and RCA inputs
- . XLR and TRS throughputs
- . Clipping and Thermal Protection

SPECIFICATIONS

- . S/N Ratio: Line 100dB, Mic 80dB
- . Frequency Response: 30 Hz – 18 kHz
- . Nominal Coverage: 90° x 60°
- . Low Frequency: 8" (210mm), 2" (50mm) Voice Coil
- . High Frequency: 25mm Voice Coil, 1"(25mm) Throat
- . Input Sensitivity: 0.5V
- . Output Sensitivity: 94dB(1m/1w→)
- . Max. SPL: 114dB
- . Balanced Input Impedance: Line 20KΩ, Mic 3.6KΩ
- . Unbalanced Input Impedance: Line 10KΩ, Mic 1.8KΩ
- . Multi Voltage Switch: AC 115V/60Hz or 230V/50Hz
- . Dimensions (LxWxH): 11.75" x 10.5" x 18"/295 x 265 x 452mm
- . Weight: 31 lbs. / 14 kgs.

CROSSOVER

- . Low Pass: 2nd order filter 2.7KHz
- . Low Cut: 2nd order filter 30Hz

CHANNEL EQUALIZER

- . Bass: 100Hz +/- 12dB
- . Treble: 10KHz +/- 12dB

COVER CPX 8A

Code: 1163100013

CPX 10A

2-way active speaker

1161330011

FEATURES

- . 2-way Speaker with High Efficiency Class D Amplifier
- . 250W Built-in Bi-amplifier
- . Time Aligned Electronic Crossover
- . 5 M8 Rigging points
- . Stand Mountable
- . Heavy Duty steel grill
- . Ergonomic handles
- . Power and Clip LED Indicators
- . XLR and RCA inputs
- . XLR and TRS throughputs
- . Clipping and Thermal Protection

SPECIFICATIONS

- . S/N Ratio: Line 100dB, Mic 80dB
- . Frequency Response: 30 Hz – 18 kHz
- . Nominal Coverage: 90° x 60°
- . Low Frequency: 10" (255mm), 2" (50mm) Voice Coil
- . High Frequency: 25mm Voice Coil, 1"(25mm) Throat
- . Input Sensitivity: 0.5V
- . Output Sensitivity: 94dB(1m/1w→)
- . Max. SPL: 114dB
- . Balanced Input Impedance: Line 20KΩ, Mic 3.6KΩ
- . Unbalanced Input Impedance: Line 10KΩ, Mic 1.8KΩ
- . Multi Voltage Switch: AC 115V/60Hz or 230V/50Hz
- . Dimensions (LxWxH): 13.75" x 12.75" x 20.5"/ 347 x 320 x 516mm
- . Weight: 40 lbs. / 17.95 kgs.

CROSSOVER

- . Low Pass: 2nd order filter 2.7KHz
- . Low Cut: 2nd order filter 30Hz

CHANNEL EQUALIZER

- . Bass: 100Hz +/- 12dB
- . Treble: 10KHz +/- 12dB

COVER CPX 10A

Code: 1163100014

CPX 12A

2-way active speaker

1161340011

FEATURES

- . 2-way Speaker with High Efficiency Class D Amplifier.
- . 500W Built-in Bi-amplifier
- . Time Aligned Electronic Crossover
- . 5 M8 Rigging points
- . Stand Mountable
- . Heavy Duty steel grill
- . Ergonomic handles
- . Power and Clip LED Indicators
- . XLR and RCA inputs
- . XLR and TRS throughputs
- . Clipping and Thermal Protection

SPECIFICATIONS

- . S/N Ratio: Line 100dB, Mic 80dB
- . Frequency Response: 30 Hz – 18 kHz
- . Nominal Coverage: 90° x 60°
- . Low Frequency: 12" (312mm), 2.5" (65mm) Voice Coil
- . High Frequency: 34mm Voice Coil, 1"(25mm) Throat
- . Input Sensitivity: 0.5V
- . Output Sensitivity: 94dB(1m/1w→)
- . Max. SPL: 114dB
- . Balanced Input Impedance: Line 20KΩ, Mic 3.6KΩ
- . Unbalanced Input Impedance: Line 10KΩ, Mic 1.8KΩ
- . Multi Voltage Switch: AC 115V/60Hz or 230V/50Hz
- . Dimensions (LxWxH): 15" x 14.25" x 23"/ 378 x 360 x 580mm
- . Weight: 48 lbs. / 21.4 kgs.

CROSSOVER

- . Low Pass: 2nd order filter 2.7KHz
- . Low Cut: 2nd order filter 30Hz

CHANNEL EQUALIZER

- . Bass: 100Hz +/- 12dB
- . Treble: 10KHz +/- 12dB

COVER CPX 12A

Code: 1163100015

CPX 15A

2-way active speaker

1161350011

FEATURES

- . 2-way Speaker with High Efficiency Class D Amplifier.
- . 500W Built-in Bi-amplifier
- . Time Aligned Electronic Crossover
- . 5 M8 Rigging points
- . Stand Mountable
- . Heavy Duty steel grill
- . Ergonomic handles
- . Power and Clip LED Indicators
- . XLR and RCA inputs
- . XLR and TRS throughputs
- . Clipping and Thermal Protection

SPECIFICATIONS

- . S/N Ratio: Line 100dB, Mic 80dB
- . Frequency Response: 30 Hz – 18 kHz
- . Nominal Coverage: 90° x 60°
- . Low Frequency: 15" (390mm), 2.5" (75mm) Voice Coil
- . High Frequency: 44mm Voice Coil, 1"(25mm) Throat
- . Input Sensitivity: 0.5V
- . Output Sensitivity: 94dB(1m/1w→)
- . Max. SPL: 114dB
- . Balanced Input Impedance: Line 20KΩ, Mic 3.6KΩ
- . Unbalanced Input Impedance: Line 10KΩ, Mic 1.8KΩ
- . Multi Voltage Switch: AC 115V/60Hz or 230V/50Hz
- . Dimensions (LxWxH): 18" x 15.5" x 27"/ 456 x 390 x 680mm
- . Weight: 62 lbs. / 28 kgs.

CROSSOVER

- . Low Pass: 2nd order filter 2.7KHz
- . Low Cut: 2nd order filter 30Hz

CHANNEL EQUALIZER

- . Bass: 100Hz +/- 12dB
- . Treble: 10KHz +/- 12dB

COVER CPX 15A

Code: 1163100016

ELS GO 8BT

Battery power speakers with Bluetooth

1161350014

Powerful, Portable ELS-GO-8BT can play anywhere, whether there is power available or not. The internal rechargeable battery lets you have great sound anywhere. Whether you are doing a presentation, playing music outdoors, or using it to as your background system as you play your favorite instrument or sing your favorite song. Perfect for rentals or production as well as extending the boundaries of any event. USB/SD and Bluetooth inputs allow you to have all the music at your fingertips. The ELS-GO-8BT is the perfect companion when you need great sound and do not have AC Power. ELS-GO-8BT- the possibilities are limitless.

FEATURES

- Lightweight, battery powered speaker with Blue tooth
- 8" USB Active speaker specifically designed for the DJ and rental market.
- Extremely high efficiency design with low power consumption and plenty of output power for those small, mid level parties.
- Microphone input (XLR+Jack) and volume control great for when you want to use it for a small PA speaker.
- Line inputs
- Line Outputs
- Master Volume control
- Bluetooth
- USB/SD Playback



ELS GO 15BT

Battery power speakers with Bluetooth

1161350013

Powerful, Portable ELS GO 15BT can play anywhere, whether there is power available or not. The internal rechargeable battery lets you have great sound anywhere. Whether you are doing a presentation, playing music outdoors, or using it to as your background system as you play your favorite instrument or sing your favorite song. Perfect for rentals or production as well as extending the boundaries of any event. USB/SD and Bluetooth inputs allow you to have all the music at your fingertips. The ELS GO 15BT is the perfect companion when you need great sound and do not have AC Power. ELS GO 8BT- the possibilities are limitless.

FEATURES

- Lightweight, battery powered + Bluetooth
- 15" USB Active speaker specifically designed for the DJ and Rental Market.
- Extremely High Efficiency design with low power consumption and plenty of output power for those small, mid level parties.
- Bi-amp Amplifier with 1 x amp powering the Titanium Driver and 1 x amp for 15" woofer with magnet.
- Microphone input (XLR+Jack) and volume control great for when you want to use it for a small PA speaker.
- Line inputs XLR + RCA
- Line Outputs XLR+Jack
- Master Volume control



PXW 18P

powered sub woofer

1161270002

SPECIFICATIONS

- . 18" Powered Sub
- . 800 watts max power
- . Pole mount
- . Fan cooled
- . XLR inputs & outputs
- . Level Control
- . Heavy duty castor wheels
- . Weight: 172 lbs. / 78 kgs.
- . Dimensions: (LxWxH) 27" x 27" x 32" / 686 x 686 x 813mm



Sense Series

The SENSE SERIES by American Audio is a multifunctional, compact and lightweight speaker system for flexible yet ambitious sound applications. The HF cabinets' asymmetric design allows for both FoH and monitor usage. The passive crossovers are fine-tuned for optimum acoustics and excellent dynamics and have been developed using complex frequency curves and delays.

SENSE 8 1162220001

SPECIFICATIONS

- . Woofer: 8" AA PA 850, Aluminium basket, 50mm voicecoil
- . Hightension driver with 44mm voicecoil mounted on a 90°x60° CD horn
- . Power Handling: 175W continuous 350W program 700W peak
- . Recommended input power: 100-250W @ 8Ohm
- . Sensitivity: 3dB SPL 121dB Peak
- . Freq. response: (-3dB) 88Hz - 20kHz
- . Freq. range: (-10dB) 75 Hz - 21kHz
- . Nom. dispersion h x v: (-6dB) 90°x60°
- . Impedance: 8Ohm
- . X-Over: 2800 Hz 12dB/18dB
- . Finish: black structure paint
- . Protective Grid: powder coated steel grill with acoustic foam
- . Connector: 2x NL4 Speaker
- . Handle: 1 handle on the top
- . Monitor angle: 45°
- . Pole mount: integrated M10 Screws for rigging eyes in all corners
- . cabinet: plywood
- . Dimensions (LxWxH): 250x436x230mm
- . Weight: 10kg

FEATURE OVERVIEW

- . Perfect matched components and case details
- . Passive full range system for medium size applications
- . Multifunctional case design
- . Quadratic horn (rotatable)
- . 90° x 60° dispersion
- . First class mechanical manufacture for day-to-day operations
- . Equipped with optimized 8" MF/LF driver
- . Large optional accessory range
- . Ideal for mobile and install applications

SENSE 12 1162240001

SPECIFICATIONS

- . Woofer: 12" AA PA1575, aluminium basket, 75mm voicecoil
- . High Driver: 1" compression driver with 44mm (1.75") voicecoil mounted on a 75°x50° CD Horn
- . Power Handling: 350W continuous 700W program 1400W peak
- . Recommended input power: 250-500W @ 8Ohm
- . Sensitivity: 98dB SPL max. 128dB Peak
- . Freq. response (-3dB): 59Hz - 20kHz
- . Freq. range(-10dB): 51 Hz - 21kHz
- . Nom. dispersion h x v (-6dB): 75°x50°
- . Impedance: 8Ohm
- . X-Over: 1800 Hz 12dB/18dB
- . Finish: black structure paint
- . Protective Grid: powder coated steel grill with acoustic foam
- . Connector: 2x NL4 Speaker
- . Handle: 1 handle on the top
- . Monitor angle: 45°
- . Pole mount: integrated
- . M10 Screws for rigging eyes in all corners
- . Cabinet: plywood
- . Dimensions (LxWxH): 360x640x325mm
- . Weight: 18kg

FEATURE OVERVIEW

- . Perfect matched components and case details
- . Passive full range system for medium size applications
- . Multifunctional case design
- . Rotatable horn
- . 75° x 50° dispersion
- . First class mechanical manufacture for day-to-day operations
- . Equipped with optimized 12" MF/LF driver
- . Large optional accessory range
- . Ideal for mobile and installed applications

COVER SENSE 12 SPEAKER Code: 1163100008

SENSE 15 1162250001

SPECIFICATIONS

- . Woofer: 15" AA PA1575, aluminium basket, 75mm voicecoil
- . High Driver: 1" compression driver with 44mm (1.75") voicecoil on a 75°x50° CD horn
- . Power Handling: 400W continuous 800W program 1600W peak
- . Recommended input power: 300-600W @ 8Ohm
- . Sensitivity: 98dB SPLmax. 129dB Peak
- . Freq. response (-3dB): 52Hz - 20kHz
- . Freq. range(-10dB): 42Hz - 21kHz
- . Nom. dispersion h x v (-6dB): 75°x50°
- . Impedance: 8Ohm
- . X-Over: 1800 Hz 12dB/18dB
- . Finish: black structure paint
- . Protective Grid: powder coated steel grill acoustic foam
- . Connector: 2x NL4 Speaker
- . Handle: 1 handle on the top
- . Monitor angle: 45°
- . Pole mount: integrated, M10 Screws for rigging eyes in all corners
- . Cabinet: plywood
- . Dimensions (LxWxH): 430x678x370mm
- . Weight: 22kg

FEATURE OVERVIEW

- . Perfect matched components and case details
- . Passive full range system for medium size applications
- . Multifunctional case design
- . Quadratic horn (rotatable)
- . 75° x 50° dispersion
- . First class mechanical manufacture for day-to-day operations
- . Equipped with optimized 15" MF/LF driver
- . Large optional accessory range
- . Ideal for mobile and install applications

COVER SENSE 15 SPEAKER Code: 1163100009



SENSE 215

1162250004

SPECIFICATIONS

- Woofer: 15" AA PA1575, aluminum basket, 75 mm voice coil
- HF Driver: 1" compression driver with 44 mm (1.75") voice coil on a 75°x50° horn
- Power Handling:
800W continuous
1600W program
3200W peak
- Recommended input power: 600...1200W at 4 Ohms
- Sensitivity: 101dB, SPLmax: 135dB peak
- Frequency response (-3dB): 60Hz - 19kHz
- Frequency range (-10dB): 45Hz - 21kHz
- Nom. Dispersion h x v (-6dB): 75° x 50°
- Impedance: 4 Ohms
- X-Over: 1800Hz 12dB / 18dB
- Finish: black structure paint
- Protective grille: powder coated sheet steel, acoustic foam
- Connector: 2x NL4 Speaker
- Handle: 2 handles in enclosure sides
- Mounting: threaded inserts for M10 screws in all enclosure corners
- Cabinet construction: Braced birch plywood
- Dimensions (L x W x H): 430 x 465 x 1110mm
- Weight : 36,9kg

SENSE 15B Subwoofer

1162270002

SPECIFICATIONS

- Woofer: 15" AA PA15000, aluminum basket, 100mm Voicecoil
- Power Handling
450W continuous
900W program
1800W peak
- Recommended input power: 300-600 W @ 8Ohm
- Components: 15" Long excursion woofer
- Sensitivity (Half Space):
102dB SPL
135dB Peak
- Freq. response: (-3dB): 45Hz - 200Hz
- Freq. range(-10dB): 40Hz - 250Hz
- Impedance: 8Ohm
- Finish: black structure paint
- Protective Grid: powder coated steel grill with acoustic foam
- Connector: 2x NL4 Speaker
- Handle: 2 handles on the sides
- Pole mount: integrated (M20)
- Cabinet: plywood
- Dimensions (LxWxH): 430x550x550mm
- Weight: 26,5kg

FEATURE OVERVIEW

- Perfect harmonized components and case details
- High efficiency
- First class mechanical manufacture for day-to-day operations
- Equipped with optimized 15" LF driver
- Large optional accessory range
- Ideal for mobile and install applications

COVER SENSE 15B SPEAKER

Code: 1163100010

SENSE 18B Subwoofer

1162270003

SPECIFICATIONS

- Woofer: 18" AA PA18000, aluminum basket, 100mm Voicecoil
- Power Handling
600W continuous
1200W program
2400W peak
- Recommended input power: 400-800 W @ 8Ohm
- Components: 18" Longexcursion woofer
- Sensitivity (Half Space)
103dB SPL
136dB Peak
- Freq. response (-3dB): 42Hz - 200Hz
- Freq. range(-10dB): 36Hz - 250Hz
- Nom. dispersion h x v (-6dB): 90°x60°
- Impedance: 8Ohm
- Finish: black structure paint
- Protective Grid: powder coated steel grill with acoustic foam
- Connector: 2x NL4 Speaker
- Handle: 2 handles on the sides
- Pole mount: integrated (M20)
- Cabinet: plywood
- Dimensions (LxWxH): 520x650x600mm
- Weight: 33kg

FEATURE OVERVIEW

- Perfect matched components and enclosure details
- High efficiency
- First class mechanical manufacture for day-to-day operations
- Equipped with optimized 18" LF driver
- Large optional accessory range
- Ideal for mobile and install applications

COVER SENSE 18B SPEAKER

Code: 1163100011





VLP2500 power amplifier

1141000012

SPECIFICATIONS

- Output Power:
 - 1100W RMS Per Channel @ 4 Ohms, 1kHz, 0.1% THD
 - 700W RMS Per Channel @ 8 Ohms, 1kHz, 0.1% THD
- Bridge Mode, Mono
 - 2200W RMS @ 8 Ohms, 1K Hz, 1% THD
- Total Harmonic Distortion: Less Than 0.5% (20Hz - 20kHz @ 8 Ohms)
- Frequency Response: (+/-01db, @rated output Power, 8 Ohms): 20Hz - 20K Hz
- Slew Rate: 20V Per usec
- Damping Factor: @ 8 Ohm: >450
- Impedance: 20 K Ohms balanced / 10 K Ohms unbalanced
- Cooling System: 2 individual fans (various speed)
- Special Features: High/Low Pass Filter/Input, Soft Start Sensitivity Selector/Ground Lift
- Output: Speaker + Binding post
- Dimensions (LxWxH): 453 x 482 x 88mm 2-rack mount space
- Weight: 22,6kg



VLP1500 power amplifier

1141000011

SPECIFICATIONS

- Output Power:
 - 675W RMS Per Channel @ 4 Ohms, 1kHz, 0.1% THD
 - 450W RMS Per Channel @ 8 Ohms, 1kHz, 0.1% THD
- Bridge Mode, Mono
 - 1400W RMS @ 8 Ohms, 1K Hz, 1% THD
- Total Harmonic Distortion: Less Than 0.1% (20Hz - 20kHz @ 8 Ohms)
- Frequency Response: (+/-01db, @rated output Power, 8 Ohms): 20Hz - 20K Hz
- Slew Rate: 15V Per usec
- Damping Factor: @ 8 Ohm: 300
- Impedance: 20 K Ohms balanced / 10 K Ohms unbalanced
- Cooling System: 2 individual fans
- Special Features: High/Low Pass Filter / Input Sensitivity Selector / Ground Lift; Limiter
- build in clip limiter
- Input: XLR 3pin + Jack 6,3mm
- output: Speaker + Binding post
- Dimensions (LxWxH): 360 x 482 x 88mm 2-rack mount spaces
- Weight: 42 lbs. / 19 Kgs.



VLP1000 power amplifier

1141000013

SPECIFICATIONS

- Output Power:
 - 500W RMS Per Channel @ 4 Ohms, 1kHz, 0.1% THD
 - 330W RMS Per Channel @ 8 Ohms, 1kHz, 0.1% THD
- Bridge Mode, Mono
 - 820W RMS @ 8 Ohms, 1K Hz, 1% THD
- Total Harmonic Distortion: Less Than 0.1% (20Hz - 20kHz @ 8 Ohms)
- Frequency Response: (+/-01db, @rated output Power, 8 Ohms): 20Hz - 20K Hz
- Slew Rate: 15V Per usec
- Damping Factor: @ 8 Ohm: 300
- Impedance: 20 Ohms balanced / 10 Ohms unbalanced
- Cooling System: 2 individual fans
- Special Features: High/Low Pass Filter / Input Sensitivity Selector / Ground Lift; Limiter
- build in clip limiter
- Input: XLR 3pin + Jack 6,3mm
- output: Speaker + Binding post
- Dimensions (LxWxH): 360 x 482 x 88mm 2-rack mount spaces
- Weight: 15 Kgs.



VLP600 power amplifier

1141000010

SPECIFICATIONS

- Output Power:
 - 300W RMS Per Channel @ 4 Ohms, 1kHz, 0.1% THD
 - 200W RMS Per Channel @ 8 Ohms, 1kHz, 0.1% THD
- Bridge Mode, Mono
 - 600W RMS @ 8 Ohms, 1K Hz, 1% THD
- Total Harmonic Distortion: Less Than 0.1% (20Hz - 20kHz @ 8 Ohms)
- Frequency Response: (+/-01db, @rated output Power, 8 Ohms): 20Hz - 20K Hz
- Slew Rate: 15V Per usec
- Damping Factor: @ 8 Ohm: 300
- Impedance: 20 Ohms balanced / 10 Ohms unbalanced
- Cooling System: 2 individual fans
- Special Features: High/Low Pass Filter / Input Sensitivity Selector / Ground Lift Limiter
- build in clip limiter
- Input: XLR 3pin + Jack 6,3mm
- output: Speaker + Binding post
- Dimensions (LxWxH): 360 x 482 x 88mm 2-rack mount spaces
- Weight: 33 lbs. / 15 Kgs.



VLP300 power amplifier

1141000009

SPECIFICATIONS

- Output Power:
 - 150W RMS Per Channel @ 4 Ohms, 1kHz, 0.1% THD
 - 100W RMS Per Channel @ 8 Ohms, 1kHz, 0.1% THD
- Bridge Mode, Mono
 - 300W RMS @ 8 Ohms, 1K Hz, 1% THD
- Total Harmonic Distortion: Less Than 0.1% (20Hz - 20kHz @ 8 Ohms)
- Frequency Response: (+/-01db, @rated output Power, 8 Ohms): 20Hz - 20K Hz
- Slew Rate: 15V Per usec
- Damping Factor: @ 8 Ohm: 260
- Impedance: 20 Ohms balanced / 10 Ohms unbalanced
- Cooling System: 2 individual fans
- Special Features: High/Low Pass Filter/Input Sensitivity Selector/Ground Lift
- Input: XLR 3pin + Jack 6,3mm
- output: Speaker + Binding post
- Dimensions (LxWxH): 336 x 482 x 44mm 1-rack mount space
- Weight: 24 lbs.(11kg)



Media Operator BT

all-in-one MP3/Bluetooth media player

1112000005



MAIN FEATURES

- SD Card* / USB 2.0 / Bluetooth full functioning MP3 Player
- Track Time Display
- Track Search Buttons
- Easy-to-use
- Bright LCD Display
- Reads SD/SDHC cards up to 32GB
- Up to 1000 MP3 songs on a 1G SD Card** (MP3 recorded at 128bit rate**)
- 4x RCA line Inputs and 1x 35mm Auxiliary Jack Input
- 1x RCA, 1x L/R Unbalanced 1/4" Jack, 1x L/R Balanced XLR

Outputs

- Master music output volume control
- Individual EQ Treble / EQ Bass control for Music
- Combo Mic input: 1/4" jack and XLR
- Master mic output volume control
- Individual EQ Treble / EQ Bass control for Mic
- Voltage Selector Switch: 115V or 230V 50/60Hz
- Dimensions (L x W x H): 19" x 4" x 1.75" in. / 483 x 193 x 44 mm (1 rack space)
- Weight: 4 lb. / 1.7 kg.

*SD Card is not Included

**Capacity may vary

DB DISPLAY MKII

1151800005

NEW



19-inch all metal rack mountable LED dB level display & amp rack lightshow

Specification

- Designed to set in an amp rack to view your decibel level
- Creates a great light show in your amp rack
- Display progresses from green through amber to red
- Sensitivity adjustment on both left and right channels
- 2 separate modes: dot and bar
- Includes 5V power supply
- Line Inputs: Left & Right RCA
- Heavy Duty Metal/ Chassis
- Line Outputs: Left & Right RCA
- Voltage Operation: DC 5V, 500mA Power Supply included
- Dimensions: (LxWxH): 19" x 1.75" x 1.75" / 44.5mm x 483mm x 44.5mm
- Weight: 2.5 lbs. / 1.25kg.

XEQ-152B Equalizer

1151100001



SPECIFICATIONS

- Input type: Active balanced / Unbalanced
- Output Impedance: <150 Ohms Input Max: (2k Ohms) +26dBu (bal.), +21dBu (unbal.) - (600 Ohms) +22dB (bal.), +15dB (unbal.)
- Input Max: +26dBu (bal.), +21dBu (unbal.)
- Output type: Servo-Balanced
- Source Impedance: 20k Ohms (bal.), 15k Ohms (unbal.)
- Min. Output Load Impedance: 600 Ohms
- Max Output Level: 22dBm
- Connectors: 1/4 phone jack, XLR & RCA phono (unbal.)
- Frequency Resp.: 20Hz-20kHz, +/-0.5dB
- Total Harmonic Distortion: <.01 +10dBu
- IM Distortion: .005
- Channel Separation: 50dB @ 1KHz
- Gain Control: - infinity to +60dB
- Filter Type: Constant Q
- Low Cut Filter: 25Hz / 12dB oct
- High Cut Filter: 3K / 12dB oct
- Range: +/- 6dB or +/- 12dB (selectable)
- S/N Ratio: 101dB below max

UCD-100 MKII

professional dual mp3/cd player

111500006

MAIN FEATURES

- . 19-inch rack mount single CD/MP3 Player
- . Plays MP3, CD, CD-R and CD-RW discs
- . LCD Display shows track name when a MP3 disc is played
- . Includes Infrared Remote Control with volume control + other features
- . 2 USB music inputs (1 on front, 1 on rear) for external music sources (hard drive, MP3 Players, Thumb Drives, SD Cards with adapters)
- . XLR Balanced Output on rear - send audio signal directly to Powered Speakers
- . RCA Outputs
- . Seamless Loop
- . Auto & Manual BPM Counter
- . +10 track advance button
- . Mechanical Anti Skip Protection
- . Quick MP3/CD recognition
- . Pitch (CD Source): Hyper Pitch (+/-4%, +/-8%, +/-16%, +/-100%)
- . Pitch (MP3 Source): (+/-4%, +/-8%, +/-16%)
- . Tempo Lock



- . Bright LCD display
- . Single/Continue Mode and Time Remaining/Time Gone-By Viewing
- . Frame search
- . Jog Wheel – control
- . Power Consumption: 13W
- . Includes American Audio Database Builder Program (PC Only – See user manual for hardware requirements)
- . Multi-voltage Power Supply: AC 100-240V, 50/60Hz
- . Dimensions (LxWxH): 19" x 10.75" x 3.5" / 482x271x89mm (2-space)
- . Weight: 10 lbs./ 4.35kg.

CONTROL FEATURES

- . Volume Control
- . Folder Search
- . Track Search
- . Mute
- . Key Lock
- . Play, Pause, Stop Buttons
- . Seamless Loop Control
- . Source Selection

UCD-200 MKII

professional dual mp3/cd player

111500007

MAIN FEATURES

- . 19-inch rack mount dual CD/MP3 Player
- . Plays MP3, CD, CD-R & CD-RW discs
- . LCD Displays shows track name when a MP3 disc is played
- . 2 USB music inputs (1 on front, 1 on rear) for external music sources (hard drive, Thumb Drives, SD Cards with adapters) . RCA Outputs . Seamless Loop
- . Auto & Manual BPM Counter
- . +10 track advance button
- . Mechanical Anti Skip Protection
- . Quick MP3/CD recognition
- . Pitch (CD Source): Hyper Pitch (+/-4%, +/-8%, +/-16%, +/-100%)
- . Pitch (MP3 Source): (+/-4%, +/-8%, +/-16%)
- . Tempo Lock . Fader Q_Start . Bright LCD displays



- . Single/Continue Mode and Time Remaining
- . Frame search . Jog Wheel – control
- . Power Consumption: 16W
- . Includes American Audio Database Builder Program (PC Only – See user manual for hardware requirements)
- . Multi-voltage Power Supply: AC 100-240V, 50/60Hz
- . Dimensions: Main Unit (LxWxH): 19" x 10.52" x 3.5" / 482x267x88.8mm (2-space)
- . Control Unit (LxWxH): 19" x 3.6" x 3.7" / 482x91.2x94mm (2-space)
- . Control Unit: 4 lbs./ 1.8 kg.
- . Weight: Main Unit: 11 lbs./ 4.8 kg.

19 MXR

112300012

4ch. professional midi/analog controller



14 MXR

112200003

4ch. professional midi/analog controller

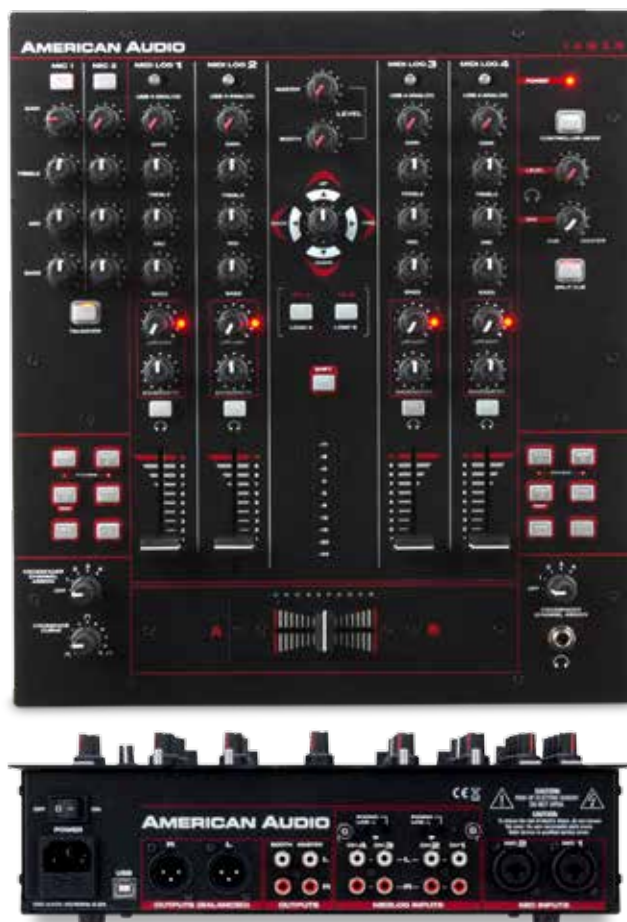

FEATURES

- . 19-inch, 4-Channel MIDIALOG™ Mixer (compatible with any "Midi Learn" Software or Analog Inputs – such as CD Players, Turntables, etc.)
- . Inputs: 4 Line, 2 Phono, 3 Mics
- . 20 On-board Midi Control Buttons (Mapable)
- . MIDI interface (USB MIDI I/O)
- . Built-in DSP D-Core™ Sound Card with 4-In/4-Out audio interface
- . Balanced XLR Outputs
- . Midi Navigation Controls to allow easy software navigation of your music library
- . Crossfader Curve Adjustment
- . Master, Booth, Headphone Level & Mix Controls
- . Microphone Volume Control + 2-Band EQ (Treble & Bass)
- . Microphone Reverb Control
- . Crossfader Assignable Low/High Pass Filter Control
- . 10 segment VU meter
- . Microphone inputs: 1x Balanced XLR, 2x ¼" Balanced
- . Dimensions (LxWxH): 19"x7.25"x 3.5" / 482x178x85mm (19-inch R.M. – 4 spaces)
- . Weight: 8 lbs. / 3.4 kg.

FEATURES

- . 14-inch, 4-Channel MIDIALOG™ Mixer (compatible with any "Midi Learn" Software or Analog Inputs – such as CD Players, Turntables, etc.)
- . Inputs: 4 Line, 2 Phono, 2 Mic
- . 20 On-board Midi Control Buttons (Mapable)
- . MIDI interface (USB MIDI I/O)
- . Built-in DSP D-Core™ Sound Card with 4-In/4-Out audio interface
- . Controller Mode: When activated USB output streams are routed through master and headphone outputs
- . Balanced XLR Outputs
- . 3-Band EQ with Rotary Kills (Treble, Mid & Bass)
- . Master, Booth, Headphone Level & Mix Controls
- . Microphone Volume Control, Talkover + 3-Band EQ (Treble, Mid & Bass)
- . Low/High Pass Filter with Bandwidth Control per channel
- . Microphone inputs: 2x Balanced ¼"/XLR Combo
- . Headphone input: ¼" Stereo
- . Dimensions (LxWxH): 14.25"x13.75"x 3.5" / 356x320x85mm
- . Weight: 10 lbs. / 4.5 kg.



VMS 5 (Velocity MIDI Station)

6 Channel Stand Alone Mixer with full Midi capability

1154000045

www.VMS4DJ.com

Visit site dedicated to VMS series Media Players..



GENERAL FEATURES

- .Midi Controller with 4 USB / Analog selectable
- .MIDILOG™ (Midi & Analog) channels
- .4 Line, 2 Phono, 2 Mic inputs
- .On/Off soft startup and turnoff
- .Gain/treble/mid/bass EQ on all MIDILOG™ channels
- .Two microphone channels with illuminated on/off switches and gain/treble/mid/bass EQs
- .On/off cueing on each MIDILOG™ channel
- .Split cueing headphones with rotary mix control
- .Multi Colored Illuminated rubber knobs for ease of use in dark environments
- .Solid 1.6mm thick faceplate for extra durability
- .Panel mounted rotary knobs
- .Full analog mixer operation with external power supply
- .Innofader replaceable crossfader compatible (sold separately)
- .Crossfader curve control
- .Crossfader assign and reverse
- .User replaceable channel faders
- .XLR Master Output with Balance Control
- .Booth Outputs
- .12 position stereo master output VU meter
- .Dimensions (LxWxH): 19"x12.75"x1.5" / 482x325x40mm
- .Weight: 13 lbs. / 6 kg

SPECIFICATIONS

- .4x Midilog™ Channels (Compatible with any "Midi Learn" Software or Analog Inputs - such as CD Players, Turntables, etc.)
- .Large Metal High Resolution Platters
- .DSP D-Core Inside: Studio Quality Audio Engine + Pro
- .Stage Microphone Circuitry
- .2x Mics with Gain, Treble, Mid & Bass Control
- .Crossfader Curve Adjustment
- .Balanced XLR Outputs
- .Multi-Function Browser knob
- .Built-in 4 In/4 Out Soundcard
- .Bundled with Virtual DJ LE Software

AUDIO FEATURES

- .24-bit 48 kHz analog audio
- .16-bit 44.1kHz USB audio
- .10-bit resolution on all analog fader controls
- .THD <0.1%*
- .Channel separation >60dB*
- .S/N ratio >85dB*
- .Analog channel audio latency < 1msec
- .Selectable USB modes: 4 in 4 out mode for running software effects on phono/line analog channels or .2 in 8 out mode for running 4 software channels and master recording
- .2 msec response on all buttons
- .4 msec response on all rotary and linear faders
- .1 msec USB latency

MIDI FEATURES

- .Two 10- bit resolution pitch sliders
- .62 assignable MIDI buttons and switches
- .50 MIDI buttons have LED illuminations, including 18 with dual blue/red LEDs
- .4 assignable rotary encoders
- .34 assignable rotary controllers
- .5 assignable linear fader controllers
- .Dual MIDI controls on all buttons and switches
- .Dual 2000 point resolution touch sensitive turntable scratch controllers



BL-40

1152200011

NEW

The American Audio BL-40 closed back headphones feature a 40mm driver unit for tight clean and loud music reproduction. With a 10Hz-22KHz frequency response, you'll be sure to get the most from your sound source.



Features:

- Comfortable on-ear cushions
- 2x Detachable headphone cables
- 3M coiled cable
- 1M straight cable with mic + volume control
- Carrying Bag
- 1/4" Phone Plug
- Adjustable headband
- Folds up for easy storage

Technical Specifications:

- Driver unit: 40mm
- Impedance: 32 ohm +/- 15%
- Sensitivity: 104 +/- 3dB
- Frequency Response: 10Hz~22KHz
- Weight: 195g +/- 10g

BL-60

1152200012

NEW

The American Audio BL-60 on ear headphones feature a 40 mm driver unit with a 10Hz-22KHz frequency response for full, rich and loud music reproduction. Comfortable, loud and punchy sound reproduction is what make the BL-60 ideal for live sound monitoring and can be used anywhere you need the extra volume but still want clean clear highs and tight bass response.



Features:

- Comfortable on-ear cushions
- 3x Detachable headphone cables
- 1M straight cable (mini to mini jack)
- 3M coiled cable (mini to mini jack)
- 3M straight cable (mini to mini jack)
- Carrying Bag
- 1/4" Phone plug adapter
- Adjustable headband
- Folds up for easy storage

Technical Specifications:

- Technical Specifications:
- Driver unit: 40mm
- Impedance: 32 ohm +/- 15%
- Sensitivity: 102 +/- 3dB
- Frequency Response: 10Hz~22KHz
- Weight: 195g +/- 10g

VPS SERIES

The American Audio VPS Series microphones were designed with singers, MC's and anyone who wants a good quality mic at a fair price in mind. Each VPS series mic has been acoustically tailored to outperform competitively priced microphones. From the least expensive VPS-20 to the VPS-80, our mics feature Cardioid and Supercardioid patterns for better feedback rejection while still retaining crystal clear audio properties in order to achieve higher gain levels before feedback. Great care has also been taken when designing the mic capsule, suspension and the barrel in order to help minimize handling noise while still remaining ergonomically comfortable and attractive.



VPS-20S

1153100007

SPECIFICATIONS

Freq Response - 50Hz - 15KHz

- Cardioid Pattern for exceptional gain before feedback
- Designed for clear vocals and reduced handling noise
- Engineered to be versatile and robust in live situations

Includes: Mic clip and 1/4 to XLR cable

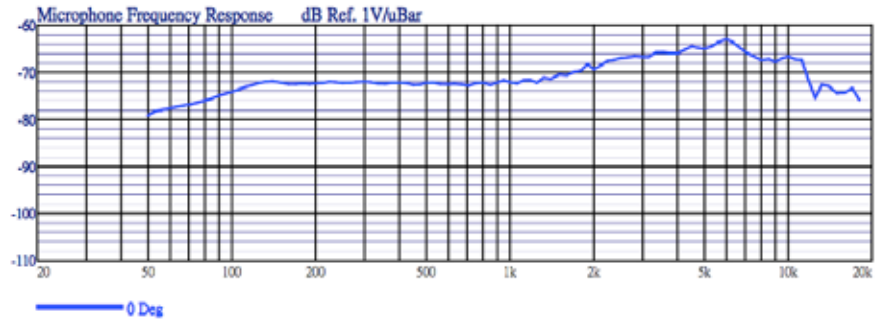

VPS-60

1153100006

SPECIFICATIONS

Freq Response - 50Hz - 18KHz

- Super Cardioid for superior gain before feedback
- Engineered to better control the proximity effect
- Minimizes handling noise without compromising sound quality

Includes: Mic clip, mic bag, XLR-XLR mic cable

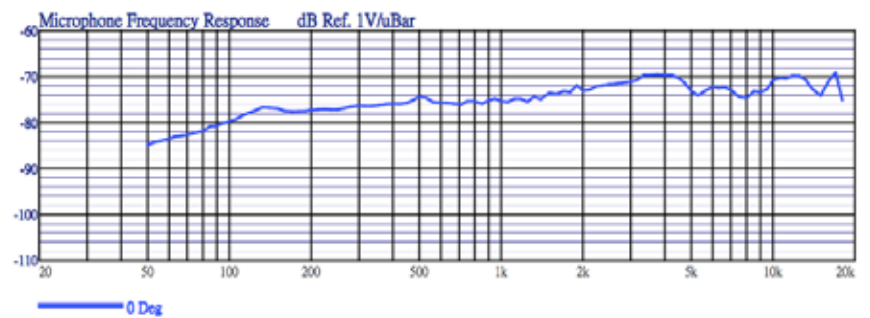

VPS-80

1153100005

SPECIFICATIONS

Freq Response - 50Hz - 18KHz

- Super Cardioid for superior gain before feedback
- Ultra-smooth frequency response for great live or studio applications
- Floating capsule suspension for greatly reduced handling noise

Includes: Mic clip, mic bag, XLR-XLR mic cable

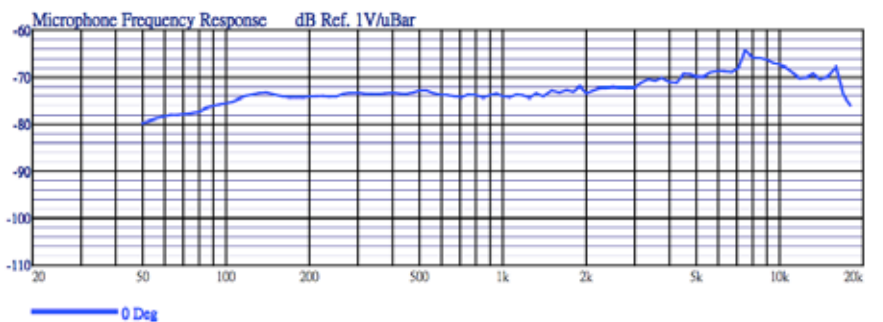

SPSX2B

116300012

Two universal ACCU STAND stands in a carry bag

SPECIFICATIONS Heavy Duty Speaker Stands

- Weight capacity: 80 lbs. / 36 kgs.
- Includes socket mounting bracket to attach to speaker
- Recommended maximum height: 6 ft.
- Pipe Diameter: 1.38" in. / 35mm
- Weight: 6 lbs. / 3.75 kgs

Whats Included:

- 2x SPS1-B Speaker Stands
- 1x Carry Bag



SAT-1 distance rod 1163900005

SPECIFICATIONS

Distance rod for Subwoofer

- Pipe diameter: 35mm Max
- Length: 1,25m
- Min. length: 0,82m
- Max. Load: 30kg
- Color: black



SAT-2 distance rod 1163900007

SPECIFICATIONS

- M 20 threaded Base

- - Pipe diameter: 35mm
- - Max length: 1,25m
- - Min length: 0,82m
- - Max. Load: 30kg
- - Color: black



UNI LTS

1154000011

FEATURES

- Universal Laptop Stand
- Adjustable height: (9.5" - 13" / 240-330 mm)
- Adjustable width: (9.25" - 11" / 235-275 mm)
- Includes two mounting clamps
- Color: black
- Material: metal
- Weight: 5 lbs. / 2.5 kg



TTS Table Top Stand 1154000009

FEATURES

- Rubberized bearing area
- Adjustable in height
- Color: black
- Material: metal
- Height: 165-225mm
- Width: 235mm
- Weight: 2,5 kg



USB LITE

USB gooseneck light

1154000022



FEATURES

- - LONG LIFE L.E.D. Goose neck light
- - For use in all Elation controllers with USB light plug.
- - Can be used with any standard USB products

Mini LED

Gooseneck lamp BNC

1154000019



FEATURES

- - Fits BNC connectors.
- - Extreme long life through LED technology.
- - Very low power consumption.
- - Produces nearly no heat.
- - LED head exchangeable.
- - Length: 37cm
- - DC 12V max 70mA

Mini LED

Gooseneck lamp XLR

1154000020



FEATURES

- - Fits XLR connectors.
- - Extreme long life through LED technology.
- - Very low power consumption.
- - Produces nearly no heat.
- - LED head exchangeable.
- - Voltage: 12V DC
- - Power: max. 70 mA
- - Length: 39cm

EVENT FACADE WH/BL

FEATURES:

- Made out of strong and light weight white metal
- Includes white scrim
- Includes a carrying bag to store and keep facade scrim looking best
- Detachable hinges make it easy for storage
- Fire Retardant easy to remove scrim
- Scrim to be washed by hand in cold water, lay flat to dry.
- Do not twist to avoid deformation
- Dimensions (LxWxH): 110.25" x 1" x 47.25" / 2800 x 25.4 x 1200mm – Complete Stand
- 27.5" x 1" x 47.25" / 700 x 25.4 x 1200mm – Each Panel 49.75" x 30" x 5.5" / 1260 x 760 x 140mm - Bag
- Weight: 32 lbs. / 14.5 kgs.



EVENT FACADE SCRIMS (4 PCS) WHITE/BLACK

White Scrims for Event Facade or Event Facade BL
BL
Set of 4 white scrims

Dimensions each scrim (WxH) : 700x1200mm
(extended)

Black Scrims for Event Facade or Event Facade BL
Set of 4 black scrims

Dimensions each scrim (WxH) : 700x1200mm
(extended)

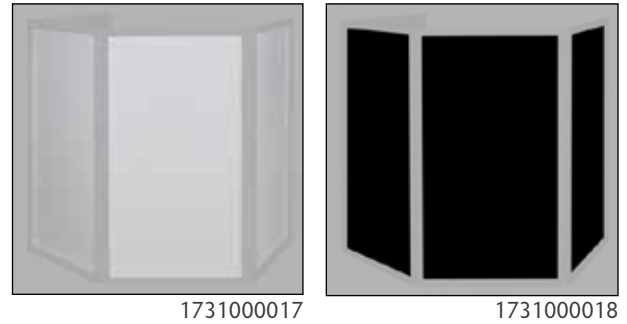

PRO EVENT TABLE

1731000019

Specification

- Professional Event Table
- Compact and collapsible
- Lightweight, around 40 lbs.
- Functional and professional looking
- Dimensions (LxWxH): 50" x 24" x 45.5" / 1270x610x1155mm



pure LIGHTING
EXCITEMENT



DISTRIBUTED BY:



AMERICAN AUDIO®



/americandj